



Minerallac[®] Company

Cully[™]

Minerallac[®]
Traditional

BlackClaw[™]

IMPACT[™]
STAPLES

REEMORE

Minerallac[®]
Strut Fittings

Minerallac[®]
STAINLESS STEEL



NEW FROM MINERALLAC

Minerallac is constantly evaluating our product lines to ensure that we provide the right product mix that electrical contractors need. To that end, Minerallac introduced two new product lines: Minerallac Strut Fittings and Accessories, and Minerallac Stainless Steel Fasteners. To learn more about these new product lines, please see their respective catalogs.

Minerallac® Strut Fittings

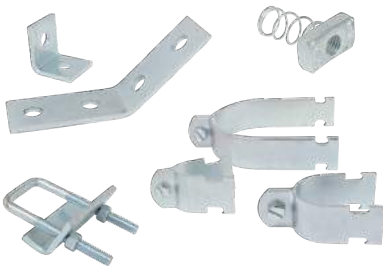

The new strut fittings and accessory line from Minerallac is made in America[†] and delivered with the Minerallac Advantage goal: 98% fill rate within 24 hours with ZERO errors.

Standard and specialty finishes include:

- 304 Stainless Steel
- 316 Stainless Steel
- Aluminum
- Hot-Dipped Galvanized
- Zinc Electroplate (EG)
- Yellow Chromate
- Powder Coated Green
- Epoxy
- Copper Chromate

Minerallac® STAINLESS STEEL



Looking for ways to increase worker safety and complete jobs that last? Take a look at the new Stainless Steel Hardware available from Minerallac.

- Strong
- Withstands harsh or corrosive environments and aggressive washdown
- Rust-resistant
- Poor electrical conductivity - safer for installation



Cully Pictorial Index

Pages 1-13

Screws

Pages 14-48

Bolts

Pages 49-54

Nuts/Washers

Pages 55-64

Grounding

Pages 65-66

Anchors

Pages 67-88

Hangers

Pages 89-98

Paints & Chemicals

Pages 99-117

Tools

Pages 118-157

Safety

Pages 158-170

Miscellaneous

Pages 171-177

Minerallac Pictorial Index

Pages 184-191

Minerallac Traditional

Pages 189-215

Stainless Steel

Pages 217-258

Strut Fittings

Pages 260-312

Black Claw

Pages 314-344

Impact Staples

Pages 346-350

Redmore

Pages 352-361

Displays

Pages 362-366

Index

Pages 367- 373

The following trademarks are the property of Minerallac Company.

Minerallac[®]
Company

Minerallac
Advantage[™]



Cully[™]

Minerallac[®]
Traditional

Minerallac[®]
STAINLESS STEEL

Minerallac[®]
Strut Fittings

Black Claw[™]

IMPACT[®]
STAPLES

REDMORE[®]

Drive Stop, Min-E, Jiffy Clip, and graphic  icon design on the Impact Staples logo are also registered trademarks of Minerallac Company.

Minerallac Company holds patents on the following; Barbed Staples Pat. No. #D484,032, Saddle Retrofit for Bridal Rings Pat. No. #6,325,338.

All other trademarks identified in this catalog are the property of the particular supplier or vendor of that product. Minerallac Company has made every attempt to correctly identify these trademarks and at no time assumes to represent these as trademarks of their own.



Cully™

PICTORIAL INDEX

SHEET METAL SCREWS



Pan Head, Sheet Metal Screw, Square
pages 14–15

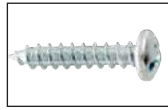

Pan Head, Sheet Metal Screw, Phillips/Slotted
page 16



Hex Washer Head, Sheet Metal Screw, Phillips/Slotted
page 17



Hex Washer Head, Sheet Metal Screw, Slotted
page 18



Round Washer Head, Sheet Metal Screw, Square
page 19



Flat Head, Sheet Metal Screw, Square
page 20

METAL PIERCING STUD SCREWS



Hex Washer Head, Stud Screw, Slotted Sharp Point
page 21



Wafer Head, Stud Screw, Phillips Sharp Point
page 21



Pan Head Framing, Phillips
page 22



Pan Head Framing, Phillips Tek
page 22

FRAMING SCREWS

TEK/SELF-DRILLING SCREWS



Pan Head Framing, Phillips Tek
page 22

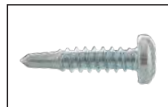

Pan Head, Square Tek
page 23



Pan Head, Phillips Tek
page 24



Hex Washer Head, Tek
pages 25–26



Wafer Head Lath, Phillips Tek
page 26

MACHINE SCREWS

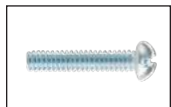

Round Head, Machine Screw, Phillips/Slotted
pages 27–28

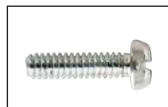

Round Head, Machine Screw, Square/Slotted
pages 29–30



Round Head Machine Screw w/Hex Nut
page 31



Flat Head, Machine Screw, Square
page 32



Flat Head, Machine Screw, Slotted
pages 33–34



Flat Head, Machine Screw, Phillips
page 34

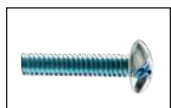

Truss Head, Machine Screw, Phillips/Slotted
page 35



Truss Head, Machine Screw, Square/Slotted
page 35

CONCRETE SCREWS



Flat Head, Concrete Screw, Phillips
page 36-27



Hex Washer Head, Concrete Screw, Slotted
page 36-37

PLATE SCREWS

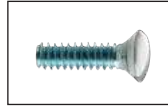

Wall Plate Oval Head, Slotted
page 38

TAMPERPROOF



Tamperproof Sheet Metal Screws
page 253-254



Tamperproof Machine Screws
page 247-248

WOOD, PARTICLE BOARD, DRYWALL & DECK SCREWS



Flat Head, Wood Screw, Square
pages 39-40

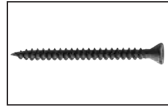

Trim Head, Wood Screw, Square
page 41

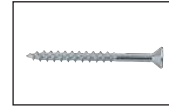

Deep Thread Particle Board, Square
pages 41-42

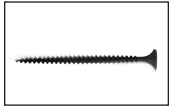

Fine Thread Drywall, Phillips
page 43



Fine Thread Drywall, Phillips Tek
page 43



Coarse Thread Drywall, Phillips
page 44

BRASS SCREWS

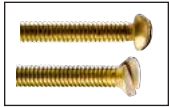

Brass Machine Screw, Round & Flat Head, Slotted
page 45

SCREW HOOKS & EYES



Screw Hooks
page 46

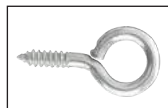

Screw Eyes
page 46



Screw Eye Lags
page 47



Acoustical Eye Tek
page 47



Acoustical Eye Lags
page 47



Acoustical Eye Driver
page 47



Eye Bolts
page 48



U-Bolts
page 48

BOLTS & LAG SCREWS

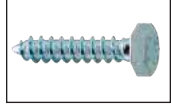

Hex Head Lag Screw
page 49



Carriage Bolts
page 50



Hex Head Bolts, Grade 2
pages 51–52



Hex Head Bolt, Grade 5
page 53



Hex Head Bolt, Silicon Bronze
page 54



Cap Screws
pages 230–233

NUTS



Hex Nuts & Grade 5
pages 55–57



Flange Whiz Nuts
page 57



Nylock Nuts
page 57



Cap Nuts
page 58



Wing Nuts
page 58

WASHERS



Flat Cut Washers
page 59–60



Fender Washers
page 61



Split Lock Washers
page 62



Toothed Lock Washers, Internal
page 63



Toothed Lock Washers, External
page 63



Sealing, Octagonal & Belleville Washers
pages 63–64



Finish Cup Washers
page 64

GROUNDING SCREWS

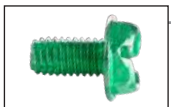

Grounding Screw
page 65



Grounding Pigtails
page 65



Grounding Clips
page 65

GROUNDING CLAMPS, RODS & ARMORED



Conduit Hubs
page 66



Ground Rod Clamps
page 66



Ground Clamps
page 66





















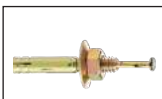





Armored Ground Clamps
page 66







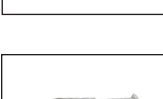

Ground Clamps with Threaded Hubs
page 66









ANCHORS

	EZ Ancors™: Zinc, Mini, & Plastic <i>pages 67–69</i>		TOGGLER® Snaptoggle® Toggle Bolt Anchors <i>page 70</i>		Toggle Bolts & Wings <i>pages 71-72</i>
	Hollow Wall Anchors <i>page 72</i>		Toggler® Snapskru™ <i>page 73</i>		Plastic Toggle Anchors <i>page 73</i>
	ALLIGATOR® Anchors <i>page 74</i>		Wedge Anchors <i>page 75</i>		Acoustical Wedge Anchors <i>page 76</i>
	Sleeve Anchors <i>page 76</i>		Strike Set Anchors <i>page 77</i>		Double Drywall <i>page 67</i>
	“Hammer Drive” Anchors <i>page 78</i>		Nylon Nail-In Anchors <i>page 79</i>		Flat Head Split Bolt Anchors <i>page 79</i>
	EZ Toggle™ Anchors <i>page 80</i>		Lag Screw Shields <i>page 81</i>		Lead Anchors <i>page 81</i>
	Steel Drop-In Anchors <i>page 82</i>		Lead Machine Screw Anchors <i>page 83</i>		Green Plug Anchors <i>page 84</i>
	Pan Head Wall Dog™ Anchors <i>page 84</i>		Red Plastic Conical Anchors <i>pages 85–86</i>		Yellow Plastic Winged Anchors <i>page 87</i>
	Expander Anchors <i>page 88</i>				

FIXTURE HANGING HARDWARE (HANGERS)

	SAMMYS® for Wood & Steel <i>pages 89–90</i>		SAMMYS® for Concrete <i>page 91</i>		SAMMYS® Nut Driver <i>pages 89–91</i>
	SAMMYS® X-Press <i>page 92</i>		Rod Hangers for Metal, Wood, & Concrete <i>pages 93–94</i>		Rod Hanger Driver Installation Tools <i>page 94</i>

FIXTURE HANGING HARDWARE (CONT.)

	Threaded Rod page 94		Hangerbolts page 95		Hangerbolts Drivers page 95
	Hex Rod & Reducing Couplings page 96		Tie Wire page 96		Jack Chain & Double Loop Tenso Chain page 97
	Plumbers Tape page 98		S-Hooks page 98		V-Hooks page 98

PAINTS & CHEMICALS

	Krylon® Inverted Marking Paint page 99		Marking Wand page 100		Can Holster page 100
	Can Adapter page 100		Krylon® Acrylic Enamel Paint page 101		Sprayon® Contact Cleaners page 104
	Sprayon® Cleaners & Degreasers page 105		Sprayon® Lubricants page 106		Sprayon® & Krylon® Corrosion Inhibitors & Insulating Varnishes page 107
	Sprayon® General Purpose & Glass Cleaners page 108		Sprayon® Insecticides & Insect Repellents page 109		Lumber Crayons page 111
	Dura-Ink 15 Marker page 111		White Lightning® Silicone Sealant page 112		EZ-Thrust Caulk Gun page 112
	Sprayon® Silicone page 112		Tri-Flow® Lubricants page 112		White Lightning® Stop Gap!™ page 113
	Wet Patch Roof Cement page 113		E-6000 Industrial Adhesive page 113		Dark Cutting Oil page 114
	Duct Seal Compound page 114				

RAGS



All Purpose Rags
page 115



Scrubs-in-a-Bucket®
page 115

FIRESTOP PRODUCTS



Firestop Putty Pad
page 116



Lectra-Stop
page 116



Firestop Gaskets
page 116



Firestop Putty Sticks
page 117



Firestop Caulk
page 117



**Sausage Firestop
Caulking Gun**
page 117



Firestop Pillows
page 117

TOOLS • SHOVELS, RAKES, SLEDGE HAMMERS, & FIBERGLASS HANDLED TOOLS



Shovels
pages 118–119



Rakes
pages 118–119



Irrigating/Floral
pages 118–119



Spades
pages 118–119



Sledge Hammers
pages 118–119



Pick Mattock
pages 118–119



Utility Probe
pages 118–119



Post Hole Digger
pages 118–119



**All Purpose Bar
with Tamper**
pages 118–119

TOOLS • TOOL BAGS & ACCESSORIES



**Electrician's Comfort
Combos**
pages 120–121



Pouches & Bags
pages 120–121



Belts & Suspenders
page 120



**Miscellaneous
Accessories**
page 120

TOOLS • SCREWDRIVERS, NUT DRIVERS, DRILL BITS, & ACCESSORIES



**Megapro®
15-in-1 Screwdrivers**
page 122



**Megapro® Quick
Change Screwdriver**
page 123



**Megapro®
16-in-1 Tamperproof
Screwdriver**
page 123



**6-in-1 Economy
Screwdriver**
page 124



**13-in-1 Ratcheting
Screwdriver**
page 124



**14-in-1 HVAC
Screwdriver**
page 124



**15-in-1 Tamperproof 2
Screwdriver**
page 124



**15-in-1 Shaftlock 2
Screwdriver**
page 125



**Spanner Drive &
Un-Do It Tool**
page 125



**Square Drive
Screwdrivers**
page 125



Blister Pack Bits
pages 126–129



**Tamperproof
29-in-1 Driver Kit**
page 130



**Tapcon™ Carbide-Tipped
Masonry Drill Bits**
page 130



Dial-A-Bit Kit
page 131



Magnetic Bit Holder
page 131



**Double Ended
Power Bit**
page 131



**Magnetizer/
Demagnetizer**
page 131



**Quick Change
Drill Adapter**
page 131



Hex Power Bits
pages 132–133



Hex Driver Bits
page 133



**Tamperproof
Insert Bits**
page 134



**High Speed
Jobber Drills**
pages 135–136



**Trinado Heavy Duty
Drills & Drill Index Set**
page 137



Hex Drill Sets
page 138



**Straight Shank
Carbide Drill Bits**
page 139



**Percussion Carbide
Drill Bits**
page 139



**SDS Rotary/Hammer
Carbide Drill Bits**
page 139



Bell Hanger Bits
page 140



Flex Shank Drill Bits
page 140



**Electrician's
Power Bits**
page 140



Ship Auger Bits
page 141



Auger Bit Extensions
page 141



**Auger
Sharpening File**
page 141

TOOLS • DRILL BITS (CONT.)



Sawtooth Self-Feeding Bits
page 142



Speedbor 2000™ Wood Bits
page 142



Step Drills
page 143

TOOLS • HOLE SAWS, ARBORS & KITS



Hole Saw Arbors
page 143



Pilot Drills
page 143



Variable Pitch Hole Saws
page 144



Hole Saw Kits
pages 144–145



Carbide Grit Hole Saws
page 145

TOOLS • TAPS & SCREW EXTRACTORS



Carbon Steel Taps
page 146



Carbon Steel Tap Wrenches
page 146



Carbon Steel Taps & Drill Set
page 146



Hex Shank Taps
page 146



Screw Extractor & Drill Bit Set
page 147



Damaged Screw Remover Set
page 147

TOOLS • SAW BLADES



Drywall Jab Saw
page 147



Hack Saw Blades
page 148



Hack Saw Frame
page 148



Reciprocating Saw Blades
page 148

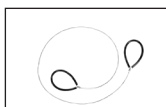

PVC Cable Saws
page 148

TOOLS • KNIVES & ACCESSORIES



Accusharp Knife Sharpener
page 149



QuickBlade™ Ergonomic Utility Knife
page 149



Titan™ Folding Pocket Utility Knife
page 149

TOOLS • MISCELLANEOUS



Uraseal Splice Kits
page 150



Tape Measure
page 151



Quickie Tie-Down Straps
page 151



Tarp Straps
page 151

TOOLS • ROPE, PISTONS, LINE PACKAGES, PULLING TAPE, & BLOW TWINE



Yellow Polypropylene Pull Rope
page 152



Polyester Pulling Tape/ Mule Tape
page 152



Polyester Conduit Measuring Tape
page 153



Polypropylene Blow Twine
page 153



Line Packages
page 153

TOOLS • CABLE MANAGEMENT



Foam Conduit Pistons
page 154

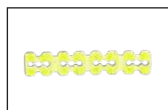

Receptical Shim
page 154



Non-Metallic Sheathed Cable Connectors
page 154



Steel Stud Bushings
page 155



Anti-Short Bushings
page 155



Knock-Out Bushings
page 155

TOOLS • TAPE



Color-Coded PVC Electrical Tape
page 156



Black PVC Electrical Tape
page 156

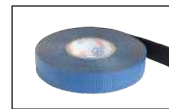

Rubber Tape
page 156



Friction Tape
page 156



Duct Tape
page 157



Carton Sealing Tape
page 157



Strapping Tape
page 157



Pipe Wrap
page 157

SAFETY • BARRICADE TAPE



Barricade & Caution Tape
page 158



Underground Burial Tape
page 158



Underground Detectable Tape
page 158

SAFETY • SAFETY GLASSES



Crossfire® Safety Glasses
pages 159–162



Nemesis™ Safety Glasses
page 163



Smith & Wesson® Safety Glasses
page 164



Hellraiser™ Safety Glasses
page 164



OTG – Over The Glasses
page 164

SAFETY • SAFETY PRODUCTS



Disposable Dust Masks
page 165



Hearing Protection
page 165



Safety Vests
page 165



Charger™ Hard Hats
page 166



Hard Hat Liners
page 166



First Aid Kits
page 167

SAFETY • WORK GLOVES



Split Leather Work Glove
page 168



1927® Cold Weather Grain Pigskin Glove
page 168



Split Leather Drivers Glove
page 168



Unlined Deerskin Drivers Glove
page 168



Unlined Grain Pigskin Drivers Glove
page 168



Grain Leather Drivers Glove
page 168



Unlined Brown Jersey Glove
page 168



Lined Brown Jersey Glove
page 168



Latex Coated Knit Glove
page 168

SAFETY • WORK GLOVES



Warm Grip Latex Work Glove
page 169



Frostbreaker® Thermal Latex Gripping Glove
page 169



Nitrile Palm Coated Glove
page 169



White String Knit Glove
page 169



PVC Dipped Glove
page 169



White Canvas Glove
page 169



Kevlar® Lined Glove
page 169



Pro-Grip Mechanic's Plus Glove
page 170



Pro-Grip Half Finger Work Glove
page 170



Pro-Grip Full Finger Work Glove
page 170



Pro-Grip Winter Plus Glove
page 170



Pro-Grip Mesh General Utility Glove
page 170

MISCELLANEOUS

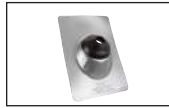

Roof Jacks
page 171



Service Entrance Caps
page 171



Pre-Kuts Plastic Sleepers
page 171

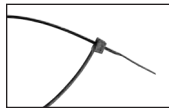

Cable Ties
page 172



Mounting Bases
page 172

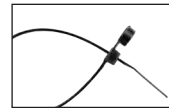

Mounting Ties
page 173



Cable Tensioning Tool & Tie Kits
page 173



Wall Plate Insulating Gaskets
page 174



Reducing Washers
page 174



Reducing Bushings
page 174



Snap-In Knock-Out Seals
page 175



3-Piece Knock-Out Seals
page 175

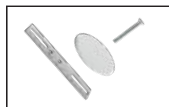

Ceiling Cover Plate
page 175



Non-Metallic Knock-Out Seals
page 175



Wire & Cable Marker Books
pages 176–177

Fasteners 14–98

SCREWS

- 14–20 Sheet Metal Screws
- 21 Metal Piercing Stud Screws
- 22 Framing Screws
- 23–26 Tek Self-Drilling Screws
- 27–35 Machine Screws
- 36–37 Tapcon™ Concrete Screws
- 38 Plate Screws
- 39–41 Wood Screws
- 42 Particle Board Screws
- 43–44 Drywall Screws
- 45 Brass Screws
- 46 Screw Hooks & Eyes
- 47 Screw & Acoustical Eye Lags

BOLTS

- 48 Eye & U-Bolts
- 49 Hex Head Lag Screws (Bolts)
- 50 Carriage Bolts
- 51–54 Hex Head Bolts

NUTS/WASHERS

- 55–57 Hex Nuts
- 58 Cap & Wing Nuts
- 59–60 Flat Cut Washers
- 61 Fender Washers
- 62 Split Lock Washers
- 63 Lock Washers, Sealing, & Octagonal Washers
- 64 Belleville & Finish Cup Washers

GROUNDING

- 65 Grounding Screws, Pigtails & Clips
- 66 Grounding Clamps, Rods, & Armored with Hubs

ANCHORS

- 67 EZ Ancors™
- 68 EZ Mini Ancors™
- 69 White Plastic EZ Ancors™
- 70 SnapToggle™ Toggle Bolt Ancors
- 71–72 Toggle Bolts & Wings
- 72 Hollow Wall Anchors
- 73 SnapSkru™ Self-Drilling Drywall Anchors
- 73 Toggler® Plastic Toggle Anchors
- 74 Toggler® Alligator® Solid Wall Anchors
- 75–79 Concrete and Masonry Anchors
- 80 EZ Toggle Ancors™
- 81 Screw Anchors
- 82–83 Bolt Anchors
- 84 Green Plug & Pan Head Wall Dog Anchors
- 85–86 Red Plastic Conical Anchors
- 87 Yellow Winged Anchors
- 88 Expander Anchors

FIXTURE HANGING HARDWARE (HANGERS)

- 89–92 Sammys® Anchoring Systems
- 93–98 Fixture Hanging Hardware
- 95 Hangerbolts & Hangerbolt Drivers

Paints & Chemicals 99–117

- 99 Inverted Marking Paint
- 100 Color Selection Guide
- 100 Paint Accessories
- 101 Acrylic Enamel Paint
- 102–103 Contact Cleaner Selection Guide
- 104 Contact Cleaners
- 105 Electrical & Electronic Cleaners & Degreasers
- 106 Lubricants
- 107 Corrosion Inhibitors & Insulating Varnishes
- 108 General Purpose & Glass Cleaner
- 109 Insect Repellents
- 110 Paint & Chemicals Technical Glossary
- 111 Markers
- 112–113 Sealants & Adhesives
- 112 Tri-Flow Lubricant
- 114 Cutting Oil & Duct Seal Compound
- 115 All Purpose Rags & Scrubs
- 116–117 Firestop Products

Tools 118–157

- 118–119 Fiberglass Handled Tools
- 120–121 Tool Bags & Accessories
- 122–123 Megapro® Screwdrivers
- 124–125 Screwdrivers
- 126–129 Blister Pack Bits
- 130 Tamperproof Driver Bits
- 131 Dial-A-Bit Kit & Driver Bit Accessories
- 132–133 Hex Power and Driver Bits
- 134 Tamperproof Insert Bits
- 135–136 High Speed Jobber Drills
- 137 Trinado Heavy-Duty Drills
- 138 Drill Sets
- 139 Carbide Drill Bits
- 140–142 Wood Bits
- 143 Step Drills, Hole Saw Arbors & Pilot Drills
- 144–145 Hole Saws
- 146 Carbon Steel & Hex Shank Taps
- 147 Screw Extractors
- 147–148 Drywall Jab Saw & Saw Blades
- 149 Knife Sharpeners & Utility Knives
- 150 Uraseal Splice Kits
- 151 Tape Measure
- 151 Tie Down Straps
- 152 Polypropylene Pull Rope & Pulling/Mule Tape
- 153 Conduit Tape, Blow Twine & Line Packages
- 154 Foam Conduit Pistons
- 154–155 Cable Management
- 156–157 Tape
- 157 Pipe Wrap

Safety 158–170

- 158 Barricade Tape
- 159–162 Crossfire® Safety Glasses
- 163–164 Safety Glasses
- 165 Dust Masks, Hearing Protection & Safety Vests
- 166 Hard Hats & Liners
- 167 First Aid Kits
- 168–170 Work Gloves

Miscellaneous 171–177

- 171 Roof Jacks, Service Entrance Caps, & Pre-Kuts
- 172–173 Cable Management
- 174 Gaskets, Reducing Washers, & Bushings
- 175 Ceiling Cover Plate & Knock-Out Seals
- 176–177 Marker Books





PAN HEAD SHEET METAL SCREWS • SQUARE DRIVE • ZINC



See page 250 for
Stainless Steel.

FASTENERS • SCREWS

		 Gravity Feed Jar			 Job Jar	
Size	Driver Bit Size	Part #	Jar Qty	Master Carton	Part #	Jar Qty
4 x 3/8	#0	10406J	100	1200	—	—
4 x 1/2	#0	10408J	100	1200	—	—
4 x 5/8	#0	10410J	100	1200	—	—
4 x 3/4	#0	10412J	100	1200	—	—
6 x 1/4	#1	10604J	100	1200	—	—
6 x 3/8	#1	10606J	100	1200	—	—
6 x 1/2	#1	10608J	100	1200	—	—
6 x 5/8	#1	10610J	100	1200	—	—
6 x 3/4	#1	10612J	100	1200	—	—
6 x 1	#1	10616J	100	1200	—	—
6 x 1 1/4	#1	10620J	100	1200	—	—
6 x 1 1/2	#1	10624J	100	1200	—	—
6 x 1 3/4	#1	10628J	100	600	—	—
6 x 2	#1	10632J	100	600	—	—
8 x 3/8	#2	10806J	100	1200	—	—
8 x 1/2	#2	10808J	100	1200	—	—
8 x 5/8	#2	10810J	100	1200	—	—
8 x 3/4	#2	10812J	100	1200	10812-6	1000
8 x 1	#2	10816J	100	1200	10816-6	750
8 x 1 1/4	#2	10820J	100	1200	10820-6	500
8 x 1 1/2	#2	10824J	100	600	10824-6	500
8 x 1 3/4	#2	10828J	100	600	—	—
8 x 2	#2	10832J	100	600	—	—
8 x 2 1/2	#2	10840J	100	600	—	—
8 x 3	#2	10848J	100	600	—	—
10 x 1/2	#2	11008J	100	1200	11008-6	1000
10 x 5/8	#2	11010J	100	1200	—	—
10 x 3/4	#2	11012J	100	1200	11012-6	750
10 x 1	#2	11016J	100	1200	11016-6	500
10 x 1 1/4	#2	11020J	100	1200	11020-6	500
10 x 1 1/2	#2	11024J	100	600	11024-6	350
10 x 1 3/4	#2	11028J	100	600	—	—
10 x 2	#2	11032J	100	600	11032-6	250
10 x 2 1/2	#2	11040J	100	600	—	—
10 x 3	#2	11048J	100	600	—	—
12 x 1/2	#3	11208J	100	1200	—	—
12 x 5/8	#3	11210J	100	1200	—	—
12 x 3/4	#3	11212J	100	1200	—	—
12 x 1	#3	11216J	100	1200	—	—
12 x 1 1/4	#3	11220J	100	600	—	—
12 x 1 1/2	#3	11224J	100	600	—	—
12 x 1 3/4	#3	11228J	100	600	—	—
12 x 2	#3	11232J	100	600	—	—
12 x 2 1/2	#3	11240J	100	600	—	—
12 x 3	#3	11248J	100	600	—	—

Continued on next page.

PAN HEAD SHEET METAL SCREWS • SQUARE DRIVE • ZINC (CONT.)

		Gravity Feed Jar		
Size	Driver Bit Size	Part #	Jar Qty	Master Carton
14 x 1/2	#3	11408J	100	1200
14 x 5/8	#3	11410J	100	1200
14 x 3/4	#3	11412J	100	1200
14 x 1	#3	11416J	100	600
14 x 1 1/4	#3	11420J	100	600
14 x 1 1/2	#3	11424J	100	600
14 x 1 3/4	#3	11428J	100	600
14 x 2	#3	11432J	100	600
14 x 2 1/2	#3	11440J	100	600
14 x 3	#3	11448J	100	600





See page 250 for
Stainless Steel.

		Kits		
Part #	Description			
39551 (396 Piece Kit)	#6 Pan Head Sheet Metal Screw Square Drive Kit Includes a #1-2" Square Drive Power Bit			
	1/2" (100 Pieces)	1" (75 Pieces)	1 1/2" (40 Pieces)	
	3/4" (100 Pieces)	1 1/4" (50 Pieces)	2" (30 Pieces)	
39552 (316 Piece Kit)	#8 Pan Head Sheet Metal Screw Square Drive Screw Kit Includes a #2-2" Square Drive Power Bit			
	1/2" (100 Pieces)	1" (50 Pieces)	1 1/2" (35 Pieces)	
	3/4" (60 Pieces)	1 1/4" (40 Pieces)	2" (30 Pieces)	
39553 (231 Piece Kit)	#10 Pan Head Sheet Metal Screw Square Drive Screw Kit Includes a #2-2" Square Drive Power Bit			
	1/2" (70 Pieces)	1" (35 Pieces)	1 1/2" (25 Pieces)	
	3/4" (50 Pieces)	1 1/4" (30 Pieces)	2" (20 Pieces)	

PAN HEAD SHEET METAL SCREWS • PHILLIPS/SLOTTED COMBO • ZINC

FASTENERS • SCREWS



		 Gravity Feed Jar			 Job Jar	
Size	Driver Bit Size	Part #	Jar Qty	Master Carton	Part #	Jar Qty
6 x 1/2	#1	18609J	1200	1200	—	—
6 x 3/4	#1	18613J	100	1200	—	—
6 x 1	#1	18617J	100	1200	—	—
6 x 1 1/4	#1	18621J	100	1200	—	—
6 x 1 1/2	#1	18625J	100	1200	—	—
8 x 1/2	#2	18809J	100	1200	—	—
8 x 3/4	#2	18813J	100	1200	18813-6	1000
8 x 1	#2	18817J	100	1200	18817-6	750
8 x 1 1/4	#2	18821J	100	1200	18821-6	500
8 x 1 1/2	#2	18825J	100	1200	—	—
8 x 2	#2	18833J	100	600	—	—
10 x 1/2	#2	19009J	100	1200	19009-6	1000
10 x 3/4	#2	19013J	100	1200	19013-6	750
10 x 1	#2	19017J	100	1200	19017-6	500
10 x 1 1/4	#2	19021J	100	1200	19021-6	500
10 x 1 1/2	#2	19025J	100	600	19025-6	350
10 x 2	#2	19033J	100	600	19033-6	250
10 x 2 1/2	#2	19041J	100	600	—	—
10 x 3	#2	19049J	100	600	—	—
12 x 1/2	#3	19209J	100	1200	—	—
12 x 3/4	#3	19213J	100	1200	—	—
12 x 1	#3	19217J	100	1200	—	—
12 x 1 1/4	#3	19221J	100	600	—	—
12 x 1 1/2	#3	19225J	100	600	—	—
12 x 2	#3	19233J	100	600	—	—
12 x 2 1/2	#3	19241J	100	600	—	—
12 x 3	#3	19249J	100	600	—	—
14 x 3/4	#3	19413J	100	1200	—	—
14 x 1	#3	19417J	100	600	—	—
14 x 1 1/4	#3	19421J	100	600	—	—
14 x 1 1/2	#3	19425J	100	600	—	—
14 x 2	#3	19433J	100	600	—	—

 Kits			
Part #	Description		
39556 (316 Piece Kit)	#8 Pan Head Sheet Metal Screw Combo Phillips/Slotted Kit Includes a #2-2" Phil Power Bit		
	1/2" (100 Pieces)	1" (50 Pieces)	1 1/2" (35 Pieces)
	3/4" (60 Pieces)	1 1/4" (40 Pieces)	2" (30 Pieces)
39557 (231 Piece Kit)	#10 Pan Head Sheet Metal Screw Combo Phillips/Slotted Kit Includes a #2-2" Phil Power Bit		
	1/2" (70 Pieces)	1" (35 Pieces)	1 1/2" (25 Pieces)
	3/4" (50 Pieces)	1 1/4" (30 Pieces)	2" (20 Pieces)

HEX WASHER HEAD SHEET METAL SCREWS • PHILLIPS/SLOTTED COMBO • ZINC

		Gravity Feed Jar			Job Jar	
Size	Head Size	Part #	Jar Qty	Master Carton	Part #	Jar Qty
10 x 1/2	5/16"	77008J	100	1200	77008-6	1000
10 x 3/4	5/16"	77012J	100	1200	77012-6	750
10 x 1	5/16"	77016J	100	1200	77016-6	500
10 x 1 1/4	5/16"	77020J	100	600	77020-6	500
10 x 1 1/2	5/16"	77024J	100	600	77024-6	350
10 x 2	5/16"	77032J	100	600	77032-6	250



FASTENERS • SCREWS

		Kits			
Part #	Description				
39562 (211 Piece Kit)	#10 HWH Sheet Metal Screw Combo Phillips/Slotted Kit				
	Includes a 5/16" Hex Driver				
	1/2" (60 Pieces)	1" (35 Pieces)	1 1/2" (25 Pieces)		
	3/4" (40 Pieces)	1 1/4" (30 Pieces)	2" (20 Pieces)		

HEX WASHER HEAD SHEET METAL SCREWS • SLOTTED • ZINC



See page 252 for
Stainless Steel.

		Gravity Feed Jar		
Size	Head Size	Part #	Jar Qty	Master Carton
6 x 1/2	1/4"	76608J	100	1200
6 x 5/8	1/4"	76610J	100	1200
6 x 3/4	1/4"	76612J	100	1200
6 x 1	1/4"	76616J	100	1200
6 x 1 1/4	1/4"	76620J	100	1200
6 x 1 1/2	1/4"	76624J	100	1200
8 x 1/2	1/4"	76808J	100	1200
8 x 5/8	1/4"	76810J	100	1200
8 x 3/4	1/4"	76812J	100	1200
8 x 1	1/4"	76816J	100	1200
8 x 1 1/4	1/4"	76820J	100	1200
8 x 1 1/2	1/4"	76824J	100	1200
8 x 2	1/4"	76832J	100	600
8 x 2 1/2	1/4"	76840J	100	600
8 x 3	1/4"	76848J	100	600
10 x 5/8	5/16"	77010J	100	1200
10 x 1 3/4	5/16"	77028J	100	600
10 x 2 1/2	5/16"	77040J	100	600
10 x 3	5/16"	77048J	100	600
12 x 1/2	5/16"	77208J	100	1200
12 x 3/4	5/16"	77212J	100	1200
12 x 1	5/16"	77216J	100	1200
12 x 1 1/4	5/16"	77220J	100	600
12 x 1 1/2	5/16"	77224J	100	600
12 x 2	5/16"	77232J	100	600
12 x 2 1/2	5/16"	77240J	100	600
12 x 3	5/16"	77248J	100	600
14 x 1/2	3/8"	77408J	100	1200
14 x 3/4	3/8"	77412J	100	600
14 x 1	3/8"	77416J	100	600
14 x 1 1/4	3/8"	77420J	100	600
14 x 1 1/2	3/8"	77424J	100	600
14 x 2	3/8"	77432J	100	600
14 x 2 1/2	3/8"	77440J	100	600
14 x 3	3/8"	77448J	100	600



Kits

Part #	Description		
39561 (286 Piece Kit)	#8 HWH Sheet Metal Screw Slotted Kit		
	Includes a 1/4" Hex Driver		
	1/2" (100 Pieces)	1" (40 Pieces)	1 1/2" (25 Pieces)
	3/4" (60 Pieces)	1 1/4" (35 Pieces)	2" (25 Pieces)

ROUND WASHER HEAD SHEET METAL SCREWS • SQUARE DRIVE • ZINC

		Gravity Feed Jar			Job Jar	
Size	Driver Bit Size	Part #	Jar Qty	Master Carton	Part #	Jar Qty
8 x 1/2	#2	14808J	100	1200	—	—
8 x 5/8	#2	14810J	100	1200	—	—
8 x 3/4	#2	14812J	100	1200	14812-6	1000
8 x 1	#2	14816J	100	1200	14816-6	750
8 x 1 1/4	#2	14820J	100	1200	14820-6	500
8 x 1 1/2	#2	14824J	100	1200	—	—
8 x 1 3/4	#2	14828J	100	600	—	—
8 x 2	#2	14832J	100	600	—	—
8 x 2 1/2	#2	14840J	100	600	—	—
10 x 1/2	#2	15008J	100	1200	15008-6	1000
10 x 3/4	#2	15012J	100	1200	15012-6	750
10 x 1	#2	15016J	100	1200	15016-6	500
10 x 1 1/4	#2	15020J	100	1200	15020-6	500
10 x 1 1/2	#2	15024J	100	600	15024-6	350
10 x 2	#2	15032J	100	600	15032-6	250
12 x 3/4	#3	15212J	100	1200	—	—
12 x 1	#3	15216J	100	1200	—	—



FASTENERS • SCREWS

		Kits			
Part #	Description				
39565 (261 Piece Kit)	#8 RWH Sheet Metal Screw Square Drive Kit Includes a #2-2" Power Bit				
	1/2" (80 Pieces)	1" (45 Pieces)	1 1/2" (30 Pieces)		
	3/4" (50 Pieces)	1 1/4" (30 Pieces)	2" (25 Pieces)		
39566 (211 Piece Kit)	#10 RWH Sheet Metal Screw Square Drive Kit Includes a #2-29 Power Bit				
	1/2" (60 Pieces)	1" (35 Pieces)	1 1/2" (22 Pieces)		
	3/4" (50 Pieces)	1 1/4" (25 Pieces)	2" (18 Pieces)		

TRUSS HEAD SHEET METAL SCREWS • SQUARE DRIVE • ZINC

		Gravity Feed Jar		
Size	Part #	Jar Qty	Master Carton	
8 x 3	14849J	100	600	
10 x 3	15049J	100	600	



FLAT HEAD SHEET METAL SCREWS • SQUARE DRIVE • ZINC



See page 251 for
Stainless Steel.

		 Gravity Feed Jar		
Size	Driver Bit Size	Part #	Jar Qty	Master Carton
6 x 3/8	#1	12606J	1200	1200
6 x 1/2	#1	12608J	100	1200
6 x 5/8	#1	12610J	100	1200
6 x 3/4	#1	12612J	1200	1200
6 x 1	#1	12616J	100	1200
6 x 1 1/4	#1	12621J	100	1200
6 x 1 1/2	#1	12625J	100	1200
8 x 1/2	#2	12808J	100	1200
8 x 5/8	#2	12810J	100	1200
8 x 3/4	#2	12812J	100	1200
8 x 1	#2	12816J	100	1200
8 x 1 1/4	#2	12821J	100	1200
8 x 1 1/2	#2	12825J	100	1200
8 x 2	#2	12833J	100	600
10 x 1/2	#2	13008J	100	1200
10 x 3/4	#2	13012J	100	1200
10 x 1	#2	13016J	100	1200
10 x 1 1/4	#2	13021J	100	1200
10 x 1 1/2	#2	13025J	100	600
10 x 2	#2	13033J	100	600
12 x 3/4	#3	13212J	100	1200
12 x 1	#3	13216J	100	1200
12 x 1 1/4	#3	13221J	100	600
12 x 1 1/2	#3	13225J	100	600

HEX WASHER HEAD SHARP POINTS • SLOTTED • ZINC

		Gravity Feed Jar			Job Jar	
Size	Driver Bit Size	Part #	Jar Qty	Master Carton	Part #	Jar Qty
7 x 1/2	1/4"	79505J	100	600	79505-6	1000
8 x 1/2	1/4"	79508J	100	1200	79508-6	1000
8 x 3/4	1/4"	79512J	100	1200	79512-6	1000
8 x 1	1/4"	79516J	100	1200	79516-6	500
8 x 1 1/2	1/4"	79524J	100	600	79524-6	500
8 x 2	1/4"	79532J	100	600	79532-6	250



FASTENERS • SCREWS

WAFER HEAD SHARP POINTS • PHILLIPS • ZINC

		Gravity Feed Jar			Job Jar	
Size	Driver Bit Size	Part #	Jar Qty	Master Carton	Part #	Jar Qty
8 x 1/2	#2	14809J	100	1200	14809-6	1000
8 x 5/16	#2	14811J	100	1200	14811-6	1000
8 x 3/4	#2	14813J	100	1200	14813-6	1000
8 x 1	#2	14817J	100	1200	14817-6	500
8 x 1 1/4	#2	14821J	100	1200	14821-6	500





		Kits		
Part #	Description			
39558 (381 Piece Kit)	#8 Wafer Head Lath Sharp Point Screw Kit Includes a #2-2" Power Bit			
	Sharp Point			
	1/2" (80 Pieces)	5/16" (60 Pieces)	3/4" (50 Pieces)	
	Tek			
	1/2" (80 Pieces)	5/16" (60 Pieces)	3/4" (50 Pieces)	



PAN HEAD FRAMING SCREWS • PHILLIPS • SUPER SHARP • BLACK





- Features sharp point metal piercing tip.
- No pre-drilling.
- Perfect for thin-gauge metal applications (up to 20 gauge).

		 Gravity Feed Jar			 Job Jar	
Size	Driver Bit Size	Part #	Jar Qty	Master Carton	Part #	Jar Qty
7 x 7/16	#2	10707J	100	1200	10707-6	1000

PAN HEAD FRAMING SCREWS • PHILLIPS • TEK • BLACK



- Great for metal-to-metal applications in steel and aluminum up to 12 gauge.

		 Gravity Feed Jar			 Job Jar	
Size	Driver Bit Size	Part #	Jar Qty	Master Carton	Part #	Jar Qty
7 x 7/16	#2	10708J	100	1200	10708-6	1000

PAN HEAD TEK SCREWS • SQUARE DRIVE • ZINC

		Gravity Feed Jar			Job Jar	
Size	Driver Bit Size	Part #	Jar Qty	Master Carton	Part #	Jar Qty
6 x 3/8	#1	26606J	100	1200	—	
8 x 1/2	#2	26808J	100	1200	26808-6	1000
8 x 5/8	#2	26810J	100	1200	—	
8 x 3/4	#2	26812J	100	1200	26812-6	750
8 x 1	#2	26816J	100	1200	26816-6	750
8 x 1 1/4	#2	26820J	100	1200	—	
10 x 1/2	#2	27008J	100	1200	27008-6	750
10 x 5/8	#2	27010J	100	1200	—	
10 x 3/4	#2	27012J	100	1200	27012-6	750
10 x 1	#2	27016J	100	1200	27016-6	500
10 x 1 1/4	#2	27020J	100	1200	27020-6	500
10 x 1 1/2	#2	27024J	100	600	27024-6	350
10 x 2	#2	27032J	100	600	27032-6	250
12 x 3/4	#3	27212J	100	1200	—	
12 x 1	#3	27216J	100	1200	—	
12 x 1 1/4	#3	27220J	100	600	—	



FASTENERS • SCREWS

Kits			
Part #	Description		
39505 (381 Piece Kit)	#8 & #10 Pan Head Square Drive Tek Screw Kit Includes a #2-2" Power Bit		
	8 x 1/2" (100 Pieces)	8 x 3/4" (60 Pieces)	8 x 1" (50 Pieces)
	10 x 1/2" (80 Pieces)	10 x 3/4" (50 Pieces)	10 x 1" (40 Pieces)

PAN HEAD TEK SCREWS • PHILLIPS • ZINC



- #6 and #8 Tek Screws feature a #1 drill point.
- #10, #12, and #14 Tek Screws feature a #2 drill point.

			 Gravity Feed Jar		
Size	Driver Bit Size	Drill Point	Part #	Jar Qty	Master Carton
6-20 x 1/2	#1	#1	82608J	100	1200
6-20 x 5/8	#1	#1	82610J	100	1200
6-20 x 3/4	#1	#1	82612J	100	1200
6-20 x 1	#1	#1	82616J	100	1200
8-18 x 1/2	#2	#1	82808J	100	1200
8-18 x 5/8	#2	#1	82810J	100	1200
8-18 x 3/4	#2	#1	82812J	100	1200
8-18 x 1	#2	#1	82816J	100	1200
8-18 x 1 1/4	#2	#1	82820J	100	1200
8-18 x 1 1/2	#2	#1	82824J	100	1200
10-16 x 1/2	#2	#2	83008J	100	1200
10-16 x 5/8	#2	#2	83010J	100	1200
10-16 x 3/4	#2	#2	83012J	100	1200
10-16 x 1	#2	#2	83016J	100	1200
10-16 x 1 1/4	#2	#2	83020J	100	1200
10-16 x 1 1/2	#2	#2	83024J	100	600

 Kits			
Part #	Description		
39507 (381 Piece Kit)	#8 & #10 Pan Head Phillips Tek Screw Kit Includes a #2-2" Power Bit		
	8 x 1/2" (100 Pieces)	8 x 3/4" (60 Pieces)	8 x 1" (50 Pieces)
	10 x 1/2" (80 Pieces)	10 x 3/4" (50 Pieces)	10 x 1" (40 Pieces)

HEX WASHER HEAD TEK SCREWS • ZINC

			Gravity Feed Jar			Job Jar	
Size	Driver Bit Size	Drill Point	Part #	Jar Qty	Master Carton	Part #	Jar Qty
6-20 x 3/8	1/4"	#1	78606J	100	1200	—	—
6-20 x 1/2	1/4"	#1	78608J	100	1200	—	—
6-20 x 3/4	1/4"	#1	78612J	100	1200	—	—
6-20 x 1	1/4"	#1	78616J	100	1200	—	—
8-18 x 1/2	1/4"	#1	78808J	100	1200	78808-6	1000
8-18 x 5/8	1/4"	#1	78810J	100	1200	—	—
8-18 x 3/4	1/4"	#1	78812J	100	1200	78812-6	750
8-18 x 1	1/4"	#1	78816J	100	1200	78816-6	750
8-18 x 1 1/4	1/4"	#1	78820J	100	1200	—	—
8-18 x 1 1/2	1/4"	#1	78824J	100	1200	—	—
10-16 x 1/2	5/16"	#2	79008J	100	1200	79008-6	750
10-16 x 5/8	5/16"	#2	79010J	100	1200	—	—
10-16 x 3/4	5/16"	#2	79012J	100	1200	79012-6	750
10-16 x 1	5/16"	#2	79016J	100	1200	79016-6	500
10-16 x 1 1/4	5/16"	#2	79020J	100	600	79020-6	500
10-16 x 1 1/2	5/16"	#2	79024J	100	600	79024-6	350
10-16 x 1 3/4	5/16"	#2	79028J	100	600	—	—
10-16 x 2	5/16"	#2	79032J	100	600	79032-6	250
10-16 x 2 1/2	5/16"	#2	79040J	100	600	—	—
10-16 x 3	5/16"	#2	79048J	100	600	—	—
12-14 x 3/4	5/16"	#2	79212J	100	1200	79212-6	500
12-14 x 1	5/16"	#2	79216J	100	1200	79216-6	350
12-14 x 1 1/4	5/16"	#2	79220J	100	600	—	—
12-24 x 1 1/4	5/16"	#2	79221J	100	600	—	—
12-14 x 1 1/2	5/16"	#2	79224J	100	600	—	—
12-14 x 2	5/16"	#2	79232J	100	600	—	—
12-14 x 2 1/2	5/16"	#2	79240J	100	600	—	—
12-14 x 3	5/16"	#2	79248J	100	600	—	—
1/4-14 x 3/4	3/8"	#2	79412J	100	600	—	—
1/4-14 x 1	3/8"	#2	79416J	100	600	—	—
1/4-14 x 1 1/4	3/8"	#2	79420J	100	600	—	—
1/4-14 x 1 1/2	3/8"	#2	79424J	100	600	—	—
1/4-14 x 2	3/8"	#2	79432J	100	600	—	—
1/4-14 x 2 1/2	3/8"	#2	79440J	100	600	—	—
1/4-14 x 3	3/8"	#2	79448J	100	600	—	—



See page 255 for
Stainless Steel.

- #6 Tek Screws feature a #1 drill point.
- #8 and #10 Tek Screws feature a #2 drill point.
- #12 and 1/4" Tek Screws feature a #3 drill point.

Continued on next page.

HEX WASHER HEAD TEK SCREWS • ZINC (CONT.)





See page 255 for
Stainless Steel.

 Kits			
Part #	Description		
Hex Washer Head Tek Kit			
39509 (307 Piece Kit)	8 x 1/2" (100 Pieces)	8 x 3/4" (50 Pieces)	8 x 1" (40 Pieces)
	10 x 1/2" (50 Pieces)	10 x 3/4" (35 Pieces)	10 x 1" (30 Pieces)
	1/4" Mag Tek Driver	5/16" Mag Hex Driver	

WAFFER HEAD LATH TEK SCREWS (K-LATH) • PHILLIPS • ZINC

• Wafer head provides a larger bearing surface.



		 Gravity Feed Jar			 Job Jar	
Size	Driver Bit Size	Part #	Jar Qty	Master Carton	Part #	Jar Qty
8 x 1/2"	#2	26809J	100	1200	26809-6	1000
8 x 5/16"	#2	26811J	100	1200	26811-6	1000
8 x 3/4"	#2	26813J	100	1200	26813-6	1000
8 x 1"	#2	26817J	100	1200	26817-6	500
8 x 1 1/4"	#2	26821J	100	1200	26821-6	500

ROUND HEAD MACHINE SCREWS • PHILLIPS/SLOTTED COMBO • ZINC

Size	Driver Bit Size	Gravity Feed Jar			Job Jar	
		Part #	Jar Qty	Master Carton	Part #	Jar Qty
6-32 x 3/8	#2	52206J	100	1200	—	—
6-32 x 1/2	#2	52208J	100	1200	52208-6	1000
6-32 x 3/4	#2	52212J	100	1200	—	—
6-32 x 1	#2	52216J	100	1200	—	—
6-32 x 1 1/4	#2	52220J	100	1200	—	—
6-32 x 1 1/2	#2	52224J	100	1200	—	—
6-32 x 2	#2	52232J	100	1200	—	—
6-32 x 2 1/2	#2	52240J	100	600	—	—
6-32 x 3	#2	52248J	100	600	—	—
8-32 x 3/8	#2	52406J	100	1200	52406-6	1000
8-32 x 1/2	#2	52408J	100	1200	52408-6	1000
8-32 x 3/4	#2	52412J	100	1200	52412-6	1000
8-32 x 1	#2	52416J	100	1200	52416-6	750
8-32 x 1 1/4	#2	52420J	100	1200	52420-6	500
8-32 x 1 1/2	#2	52424J	100	1200	52424-6	500
8-32 x 2	#2	52432J	100	600	52432-6	250
8-32 x 2 1/2	#2	52440J	100	600	—	—
8-32 x 3	#2	52448J	100	600	—	—
8-32 x 3 1/2 (slot only)	#2	52356J	100	600	—	—
8-32 x 4 (combo)	#2	52364J	100	600	—	—
10-24 x 3/8	#2	52606J	100	1200	—	—
10-24 x 1/2	#2	52608J	100	1200	—	—
10-24 x 3/4	#2	52612J	100	1200	—	—
10-24 x 1	#2	52616J	100	1200	—	—
10-24 x 1 1/4	#2	52620J	100	1200	—	—
10-24 x 1 1/2	#2	52624J	100	600	—	—
10-24 x 2	#2	52632J	100	600	—	—
10-24 x 3	#2	52648J	100	600	—	—
10-32 x 1/2	#2	52809J	100	1200	52809-6	1000
10-32 x 3/4	#2	52813J	100	1200	—	—
10-32 x 1	#2	52817J	100	1200	—	—
10-32 x 1 1/4	#2	52821J	100	1200	—	—
10-32 x 1 1/2	#2	52825J	100	600	—	—
10-32 x 2	#2	52833J	100	600	—	—



FASTENERS • SCREWS

Continued on next page.

ROUND HEAD MACHINE SCREWS • PHILLIPS/SLOTTED COMBO • ZINC (CONT.)

FASTENERS • SCREWS



Size	Driver Bit Size	Gravity Feed Jar			Job Jar	
		Part #	Jar Qty	Master Carton	Part #	Jar Qty
¼-20 x ⅜	#3	53006J	100	1200	53006-6	500
¼-20 x ½	#3	53008J	100	1200	53008-6	500
¼-20 x ¾	#3	53012J	100	1200	53012-6	500
¼-20 x 1	#3	53016J	100	600	53016-6	350
¼-20 x 1¼	#3	53020J	100	600	—	—
¼-20 x 1½	#3	53024J	100	600	—	—
¼-20 x 2	#3	53032J	100	600	—	—
¼-20 x 2½	#3	53040J	100	600	—	—
¼-20 x 3	#3	53048J	100	600	—	—
¼-20 x 4	#3	53064J	100	600	—	—
⅜-16 x ¾	#3	53212J	100	600	—	—
⅜-16 x 1	#3	53216J	100	600	—	—
⅜-16 x 1¼	#3	53220J	100	600	—	—
⅜-16 x 1½	#3	53224J	100	600	—	—
⅜-16 x 2	#3	53232J	100	600	—	—
⅜-16 x 3	#3	53248J	50	300	—	—
⅜-16 x 4	#3	53264J	50	300	—	—

Kits			
Part #	Description		
39525 (370 Piece Kit)	6-32 Combo RH Machine Screw Kit		
	6-32 x ½" (100 Pieces)	6-32 x 1" (75 Pieces)	6-32 x 1½" (40 Pieces)
	6-32 x ¾" (75 Pieces)	6-32 x 1¼" (50 Pieces)	6-32 x 2" (30 Pieces)
39526 (310 Piece Kit)	8-32 Combo RH Machine Screw Kit		
	8-32 x ½" (100 Pieces)	8-32 x 1" (50 Pieces)	8-32 x 1½" (35 Pieces)
	8-32 x ¾" (60 Pieces)	8-32 x 1¼" (40 Pieces)	8-32 x 2" (25 Pieces)
39538 (245 Piece Kit)	10-24 Combo RH Machine Screw Kit		
	10-24 x ½" (75 Pieces)	10-24 x 1" (40 Pieces)	10-24 x 1½" (25 Pieces)
	10-24 x ¾" (50 Pieces)	10-24 x 1¼" (30 Pieces)	10-24 x 2" (25 Pieces)
39532 (245 Piece Kit)	10-32 Combo RH Machine Screw Kit		
	10-32 x ½" (75 Pieces)	10-32 x 1" (40 Pieces)	10-32 x 1½" (25 Pieces)
	10-32 x ¾" (50 Pieces)	10-32 x 1¼" (30 Pieces)	10-32 x 2" (25 Pieces)
39536 (152 Piece Kit)	¼-20 Combo RH Machine Screw Kit		
	¼-20 x ⅜" (40 Pieces)	¼-20 x ¾" (30 Pieces)	¼-20 x 1½" (15 Pieces)
	¼-20 x ½" (35 Pieces)	¼-20 x 1" (20 Pieces)	¼-20 x 2" (12 Pieces)

ROUND HEAD MACHINE SCREWS • SQUARE/SLOTTED COMBO • ZINC

		 Gravity Feed Jar		
Size	Driver Bit Size	Part #	Jar Qty	Master Carton
6-32 x 1/4	#1	22504J	100	1200
6-32 x 3/8	#1	22506J	100	1200
6-32 x 1/2	#1	22508J	100	1200
6-32 x 3/4	#1	22512J	100	1200
6-32 x 1	#1	22516J	100	1200
6-32 x 1 1/4	#1	22520J	100	1200
6-32 x 1 1/2	#1	22524J	100	1200
6-32 x 2	#1	22532J	100	1200
8-32 x 3/8	#2	22606J	100	1200
8-32 x 1/2	#2	22608J	100	1200
8-32 x 5/8	#2	22610J	100	1200
8-32 x 3/4	#2	22612J	100	1200
8-32 x 1	#2	22616J	100	1200
8-32 x 1 1/4	#2	22620J	100	1200
8-32 x 1 1/2	#2	22624J	100	1200
8-32 x 2	#2	22632J	100	600
10-24 x 1/2	#2	22708J	100	1200
10-24 x 3/4	#2	22712J	100	1200
10-24 x 1	#2	22716J	100	1200
10-24 x 1 1/2	#2	22724J	100	600
10-24 x 2	#2	22732J	100	600
10-24 x 2 1/2	#2	22740J	100	600
10-24 x 3	#2	22748J	100	600

Continued on next page.



FASTENERS • SCREWS

ROUND HEAD MACHINE SCREWS • SQUARE/SLOTTED COMBO • ZINC (CONT.)



		 Gravity Feed Jar		
Size	Driver Bit Size	Part #	Jar Qty	Master Carton
10-32 x 1/2	#2	22808J	100	1200
10-32 x 3/4	#2	22812J	100	1200
10-32 x 1	#2	22816J	100	1200
10-32 x 1 1/4	#2	22820J	100	1200
10-32 x 1 1/2	#2	22824J	100	600
10-32 x 2	#2	22832J	100	600
1/4-20 x 3/8	#3	23006J	100	1200
1/4-20 x 1/2	#3	23008J	100	1200
1/4-20 x 3/4	#3	23012J	100	1200
1/4-20 x 1	#3	23016J	100	600
1/4-20 x 1 1/4	#3	23020J	100	600
1/4-20 x 1 1/2	#3	23024J	100	600
1/4-20 x 2	#3	23032J	100	600
1/4-20 x 2 1/2	#3	23040J	50	300

 Kits			
Part #	Description		
39527 (310 Piece Kit)	8-32 Round Head Square/Slotted Drive Machine Screw Kit		
	8-32 x 1/2" (100 Pieces)	8-32 x 1" (50 Pieces)	8-32 x 1 1/2" (35 Pieces)
	8-32 x 3/4" (60 Pieces)	8-32 x 1 1/4" (40 Pieces)	8-32 x 2" (25 Pieces)
39534 (245 Piece Kit)	10-32 Round Head Square/Slotted Machine Screw Kit		
	10-32 x 1/2" (75 Pieces)	10-32 x 1" (40 Pieces)	10-32 x 1 1/2" (25 Pieces)
	10-32 x 3/4" (50 Pieces)	10-32 x 1 1/4" (30 Pieces)	10-32 x 2" (25 Pieces)
39537 (152 Piece Kit)	1/4-20 Round Head Square/Slotted Machine Screw Kit		
	1/4-20 x 1/2" (40 Pieces)	1/4-20 1" (30 Pieces)	1/4-20 1 1/2" (15 Pieces)
	1/4-20 3/4" (35 Pieces)	1/4-20 1 1/4" (20 Pieces)	1/4-20 2" (12 Pieces)

ROUND HEAD MACHINE SCREW WITH HEX NUTS • PHILLIPS/SLOTTED COMBO • ZINC

Gravity Feed Jar			
Size	Part #	Jar Qty	Master Carton
1/4-20 x 1/2	25508J	100	600
1/4-20 x 3/4	25512J	100	600
1/4-20 x 1	25516J	100	600
1/4-20 x 1 1/4	25520J	100	600
1/4-20 x 1 1/2	25524J	100	600
1/4-20 x 2	25532J	100	600
1/4-20 x 2 1/2	25540J	100	600
1/4-20 x 3	25548J	100	600
3/8-16 x 1	25716J	100	600
3/8-16 x 1 1/4	25720J	100	600
3/8-16 x 1 1/2	25724J	100	600
3/8-16 x 2	25732J	100	600



See page 246 for
Stainless Steel.

FASTENERS • SCREWS

Kits	
Part #	Description
10-24 (3/16) Stove Bolt Kit	
39539 (440 Piece Kit)	10-24 x 1/2" (60 Pieces) 10-24 x 1" (40 Pieces) 10-24 x 1 1/2" (20 Pieces)
	10-24 x 3/4" (50 Pieces) 10-24 x 1 1/4" (30 Pieces) 10-24 x 2" (20 Pieces)
	10-24 Hex Nut (220 Pieces)
1/4-20 Stove Bolt Kit	
39540 (220 Piece Kit)	1/4-20 x 1/2" (30 Pieces) 1/4-20 x 1" (20 Pieces) 1/4-20 x 1 1/2" (10 Pieces)
	1/4-20 x 3/4" (25 Pieces) 1/4-20 x 1 1/4" (15 Pieces) 1/4-20 x 2" (10 Pieces)
	1/4-20 Hex Nut (110 Pieces)

FLAT HEAD MACHINE SCREWS • SQUARE DRIVE • ZINC



 Gravity Feed Jar

Size	Driver Bit Size	Part #	Jar Qty	Master Carton
6-32 x ¼	#1	20504J	100	1200
6-32 x ½	#1	20508J	100	1200
6-32 x ¾	#1	20512J	100	1200
6-32 x 1	#1	20516J	100	1200
6-32 x 1¼	#1	20520J	100	1200
6-32 x 1½	#1	20524J	100	1200
6-32 x 2	#1	20532J	100	1200
8-32 x ½	#2	20608J	100	1200
8-32 x ¾	#2	20612J	100	1200
8-32 x 1	#2	20616J	100	1200
8-32 x 1¼	#2	20620J	100	1200
8-32 x 1½	#2	20624J	100	1200
8-32 x 2	#2	20632J	100	600
10-24 x ½	#2	20708J	100	1200
10-24 x ¾	#2	20712J	100	1200
10-24 x 1	#2	20716J	100	1200
10-24 x 1¼	#2	20720J	100	1200
10-24 x 1½	#2	20724J	100	600
10-24 x 2	#2	20732J	100	600
10-24 x 2½	#2	20740J	100	600
10-24 x 3	#2	20748J	100	600
10-32 x ½	#2	20808J	100	1200
10-32 x ¾	#2	20812J	100	1200
10-32 x 1	#2	20816J	100	1200
10-32 x 1¼	#2	20820J	100	1200
¼-20 x ½	#3	21008J	100	1200
¼-20 x ¾	#3	21012J	100	1200
¼-20 x 1	#3	21016J	100	600
¼-20 x 1¼	#3	21020J	100	600
¼-20 x 1½	#3	21024J	100	600
¼-20 x 2	#3	21032J	100	600
¼-20 x 2½	#3	21040J	50	300
¼-20 x 3	#3	21048J	50	300

FLAT HEAD MACHINE SCREWS • SLOTTED • ZINC

		Gravity Feed Jar		
Size	Driver Bit Size	Part #	Jar Qty	Master Carton
6-32 x 1/2	#6-#8	50108J	100	1200
6-32 x 3/4	#6-#8	50112J	100	1200
6-32 x 1	#6-#8	50116J	100	1200
6-32 x 1 1/4	#6-#8	50120J	100	1200
6-32 x 1 1/2	#6-#8	50124J	100	1200
6-32 x 1 3/4	#6-#8	50128J	100	1200
6-32 x 2	#6-#8	50132J	100	600
6-32 x 2 1/2	#6-#8	50140J	100	600
6-32 x 3	#6-#8	50148J	100	600
6-32 x 4	#6-#8	50164J	100	600
8-32 x 3/8	#8-#10	50306J	100	1200
8-32 x 1/2	#8-#10	50308J	100	1200
8-32 x 3/4	#8-#10	50312J	100	1200
8-32 x 1	#8-#10	50316J	100	1200
8-32 x 1 1/4	#8-#10	50320J	100	1200
8-32 x 1 1/2	#8-#10	50324J	100	1200
8-32 x 2	#8-#10	50332J	100	600
8-32 x 2 1/2	#8-#10	50340J	100	600
8-32 x 3	#8-#10	50348J	100	600
10-24 x 1/2	#10-#12	50508J	100	1200
10-24 x 3/4	#10-#12	50512J	100	1200
10-24 x 1	#10-#12	50516J	100	1200
10-24 x 1 1/4	#10-#12	50520J	100	1200
10-24 x 1 1/2	#10-#12	50524J	100	600
10-24 x 2	#10-#12	50532J	100	600
10-24 x 2 1/2	#10-#12	50540J	100	600
10-24 x 3	#10-#12	50548J	100	600
10-32 x 1/2	#10-#12	50708J	100	1200
10-32 x 3/4	#10-#12	50712J	100	1200
10-32 x 1	#10-#12	50716J	100	1200
10-32 x 1 1/4	#10-#12	50720J	100	1200
10-32 x 1 1/2	#10-#12	50724J	100	600
10-32 x 2	#10-#12	50732J	100	600
10-32 x 2 1/2	#10-#12	50740J	100	600
10-32 x 3	#10-#12	50748J	100	600
1/4-20 x 1/2	#12-#14	50908J	100	1200
1/4-20 x 3/4	#12-#14	50912J	100	1200
1/4-20 x 1	#12-#14	50916J	100	600
1/4-20 x 1 1/4	#12-#14	50920J	100	600
1/4-20 x 1 1/2	#12-#14	50924J	100	600
1/4-20 x 2	#12-#14	50932J	100	600
1/4-20 x 2 1/2	#12-#14	50940J	50	300
1/4-20 x 3	#12-#14	50948J	50	300



See page 245 for
Stainless Steel.

FLAT HEAD MACHINE SCREWS • SLOTTED • ZINC (CONT.)



 Kits			
Part #	Description		
39541 (415 Piece Kit)	6-32 Flat Head Slot Machine Screw Kit		
	6-32 x 1/2" (100 Pieces)	6-32 x 1" (75 Pieces)	6-32 x 1 1/2" (45 Pieces)
	6-32 x 3/4" (100 Pieces)	6-32 x 1 1/4" (55 Pieces)	6-32 x 2" (40 Pieces)

See page 245 for
Stainless Steel.

FLAT HEAD MACHINE SCREWS • PHILLIPS • ZINC



		 Gravity Feed Jar		
Size	Driver Bit Size	Part #	Jar Qty	Master Carton
6-32 x 1/2	#1	50109J	100	1200
6-32 x 3/4	#1	50113J	100	1200
6-32 x 1	#1	50117J	100	1200
6-32 x 1 1/4	#1	50121J	100	1200
6-32 x 1 1/2	#1	50125J	100	1200
6-32 x 2	#1	50133J	100	600
6-32 x 2 1/2	#1	50141J	100	600
6-32 x 3	#1	50149J	100	600
8-32 x 1 1/2	#2	50325J	100	1200



See page 245 for
Stainless Steel.

TRUSS HEAD MACHINE SCREWS • PHILLIPS/SLOTTED • ZINC

		Gravity Feed Jar			Job Jar	
Size	Driver Bit Size	Part #	Jar Qty	Master Carton	Part #	Jar Qty
6-32 x 1/2	#2	52008J	100	1200	—	—
6-32 x 3/4	#2	52012J	100	1200	—	—
6-32 x 1	#2	52016J	100	1200	52016-6	750
6-32 x 1 1/4	#2	52020J	100	1200	—	—
6-32 x 1 1/2	#2	52024J	100	1200	52024-6	500
6-32 x 2	#2	52032J	100	600	52032-6	350
6-32 x 3	#2	52048J	100	600	—	—
6-32 x 4	#2	52064J	100	600	—	—
10-24 x 2	#2	52133J	100	600	—	—
10-24 x 3	#2	52149J	100	600	—	—
10-24 x 4	#2	52165J	100	600	—	—
1/4-20 x 3	#3	52249J	100	600	—	—
1/4-20 x 4	#3	52265J	100	600	—	—

- Designed for use with receptacles.

		Kits			
Part #	Description				
39546 (380 Piece Kit)	6-32 Truss Head Machine Screw Combo Kit				
	1/2" (100 Pieces)	1" (65 Pieces)	1 1/2" (40 Pieces)		
	3/4" (90 Pieces)	1 1/4" (50 Pieces)	2" (35 Pieces)		



FASTENERS • SCREWS

TRUSS HEAD MACHINE SCREWS • SQUARE/SLOTTED • ZINC

		Gravity Feed Jar		
Size	Driver Bit Size	Part #	Jar Qty	Master Carton
6-32 x 2	#1	24433J	100	600
6-32 x 3	#1	24449J ★	100	600
6-32 x 4	#1	24465J ★	100	600
8-32 x 1/2	#2	24608J	100	1200
10-24 x 2	#2	24733J	100	600
10-24 x 3	#2	24749J	100	600
10-24 x 4	#2	24765J	100	600
1/4-20 x 3	#3	25049J	100	600
1/4-20 x 4	#3	25065J	100	600

- ★ Made in USA



HEX WASHER HEAD CONCRETE SCREWS • SLOTTED



		Gravity Feed Jar		
Size	Drill	Part #	Jar Qty	Master Carton
3/16 X 1 1/4	5/32 X 3 1/2	60120NDJ	100	600
3/16 X 1 3/4	5/32 X 3 1/2	60128NDJ	100	600
3/16 X 2 1/4	5/32 X 4 1/2	60136NDJ	100	600
3/16 X 2 3/4	5/32 X 4 1/2	60144NDJ	100	600
3/16 X 3 1/4	5/32 X 5 1/2	60152NDJ	100	600
3/16 X 3 3/4	5/32 X 5 1/2	60160NDJ	100	600
3/16 X 4	5/32 X 5 1/2	60164NDJ	100	600
1/4 X 1 1/4	3/16 X 3 1/2	60320NDJ	100	600
1/4 X 1 3/4	3/16 X 3 1/2	60328NDJ	100	600
1/4 X 2 1/4	3/16 X 4 1/2	60336NDJ	100	600
1/4 X 2 3/4	3/16 X 4 1/2	60344NDJ	100	600
1/4 X 3 1/4	3/16 X 4 1/2	60352NDJ	100	600
1/4 X 3 3/4	3/16 X 5 1/2	60360NDJ	100	600
1/4 X 4	3/16 X 5 1/2	60364NDJ	100	600

*ND - Non-Domestic

FLAT HEAD CONCRETE SCREWS • PHILLIPS



		Gravity Feed Jar		
Size	Drill	Part #	Jar Qty	Master Carton
3/16 X 1 1/4	5/32 X 3 1/2	60520NDJ	100	600
3/16 X 1 3/4	5/32 X 3 1/2	60528NDJ	100	600
3/16 X 2 1/4	5/32 X 4 1/2	60536NDJ	100	600
3/16 X 2 3/4	5/32 X 4 1/2	60544NDJ	100	600
3/16 X 3 1/4	5/32 X 5 1/2	60552NDJ	100	600
3/16 X 3 3/4	5/32 X 5 1/2	60560NDJ	100	600
1/4 X 1 1/4	3/16 X 3 1/2	60720NDJ	100	600
1/4 X 1 3/4	3/16 X 3 1/2	60728NDJ	100	600
1/4 X 2 1/4	3/16 X 4 1/2	60736NDJ	100	600
1/4 X 3 1/4	3/16 X 4 1/2	60752NDJ	100	600
1/4 X 3 3/4	3/16 X 5 1/2	60760NDJ	100	600
1/4 X 4	3/16 X 5 1/2	60764NDJ	100	600

*ND - Non-Domestic

CONDRIVE INSTALLATION TOOL



		Kits		
Part #	Description			
	CondriVE 1000 Installation Tool			
61102 ★ (Tool Kit)	1 Drill Driver	1 Phillips Bit Holder	2 Hex Driver	
	1 Drill Adaptor	2 Phillips Bits	1 Allen Hex Key	
	CondriVE 500 Installation Tool			
61103 ★ (Tool Kit)	1 Drill Driver	2 Phillips Bits		
	1 Drill Adaptor	1 Allen Hex Key		

★ Made in USA

CONCRETE SCREWS • HEX WASHER HEAD • SLOTTED

		Gravity Feed Jar		
Size	Drill	Part #	Jar Qty	Master Carton
3/16 X 1 1/4	5/32 X 3 1/2	60120J ★	100	600
3/16 X 2 3/4	5/32 X 4 1/2	60144J ★	100	600
3/16 X 3 1/4	5/32 X 5 1/2	60152J ★	100	600
3/16 X 3 3/4	5/32 X 5 1/2	60160J ★	100	1000
3/16 X 4	5/32 X 5 1/2	60164J ★	100	600
1/4 X 1 1/4	3/16 X 3 1/2	60320J ★	100	600
1/4 X 1 3/4	3/16 X 3 1/2	60328J ★	100	600
1/4 X 2 1/4	3/16 X 4 1/2	60336J ★	100	600
1/4 X 2 3/4	3/16 X 4 1/2	60344J ★	100	600
1/4 X 3 1/4	3/16 X 4 1/2	60352J ★	100	600
1/4 X 4	3/16 X 5 1/2	60364J ★	100	600

FREE DRILL BIT IN EVERY PACK

★ Made in USA

		Kits		
Part #	Description			
62006 ★ (112 Piece Kit)	1/4" Diameter Concrete Screw Kit			
	1 1/4" (50 Piece)	1 3/4" (35 Piece)	2 1/4" (25 Piece)	
	3 1/2" Bit (1)	4 1/2" Bit (1)		

★ Made in USA

FLAT HEAD CONCRETE SCREWS • PHILLIPS

		Gravity Feed Jar		
Size	Drill	Part #	Jar Qty	Master Carton
3/16 X 1 1/4	5/32 X 3 1/2	60520J ★	100	600
3/16 X 1 3/4	5/32 X 3 1/2	60528J ★	100	600
3/16 X 2 1/4	5/32 X 4 1/2	60536J ★	100	600
3/16 X 2 3/4	5/32 X 4 1/2	60544J ★	100	600
3/16 X 3 1/4	5/32 X 5 1/2	60552J ★	100	600
3/16 X 3 3/4	5/32 X 5 1/2	60560J ★	100	600
3/16 X 4	5/32 X 5 1/2	60564J ★	100	600
1/4 X 1 3/4	3/16 X 3 1/2	60728J ★	100	600
1/4 X 2 1/4	3/16 X 4 1/2	60736J ★	100	600
1/4 X 2 3/4	3/16 X 4 1/2	60744J ★	100	600
1/4 X 3 1/4	3/16 X 4 1/2	60752J ★	100	600
1/4 X 4	3/16 X 5 1/2	60764J ★	100	600

★ Made in USA



- ICC# 3320
- GSA 523
- MetroDade #90-1223
- NIS-64269

FASTENERS • SCREWS



WALL PLATE SCREWS • SLOTTED • 6-32 OVAL HEAD



51109J



51108J



Length	Color	Part #	Jar Qty	Master Carton
5/16	White	51104J	100	1200
1/2	White	51109J	100	1200
3/4	White	51113J	100	1200
1	White	51117J	100	1200
5/16	Ivory	51105J	100	1200
1/2	Ivory	51108J	100	1200
3/4	Ivory	51112J	100	1200
1	Ivory	51116J	100	1200
5/16	Lt. Almd	51103J	100	1200
1/2	Lt. Almd	51107J	100	1200
3/4	Lt. Almd	51111J	100	1200
1	Lt. Almd	51115J	100	1200
1/2	Brown	51110J	100	1200
3/4	Brown	51114J	100	1200
1	Brown	51118J	100	1200
1/2	Nyln Ivry	53708J	100	1200
3/4	Nyln Ivry	53712J	100	1200
1	Nyln Ivry	53716J	100	1200
1/2	Nyln Wht	53808J	100	1200
3/4	Nyln Wht	53812J	100	1200



Kits

Part #	Description					
39515 (600 Piece Kit)	White & Ivory Wall Plate Screw Kit					
	5/16" White (100 Pieces)	1/2" White (100 Pieces)	3/4" White (100 Pieces)			
	5/16" Ivory (100 Pieces)	1/2" Ivory (100 Pieces)	3/4" Ivory (100 Pieces)			
39514 (300 Piece Kit)	Light Almond Wall Plate Screw Kit					
	5/16" Lt. Almond (75 Pieces)	3/4" Lt. Almond (75 Pieces)				
	1/2" Lt. Almond (75 Pieces)	1" Lt. Almond (75 Pieces)				
39508 (300 Piece Kit)	Residential Wall Plate Screw Kit					
	1/2" Wall Plate					
	White (50 Pieces)		Ivory (50 Pieces)		Light Almond (50 Pieces)	
	5/16" Decora					
	White (50 Pieces)		Ivory (50 Pieces)		Light Almond (50 Pieces)	

All kits are standard packed 5 units per sleeve.

FLAT HEAD WOOD SCREWS • SQUARE DRIVE • ZINC

		 Gravity Feed Jar		
Size	Driver Bit Size	Part #	Jar Qty	Master Carton
4 x 3/8**	#0	12406J	100	1200
4 x 1/2**	#0	12408J	100	1200
4 x 3/4**	#0	12412J	100	1200
4 x 1**	#0	12416J	100	1200
6 x 1/2**	#1	12608J	100	1200
6 x 5/8**	#1	12610J	100	1200
6 x 3/4**	#1	12612J	100	1200
6 x 1**	#1	12616J	100	1200
6 x 1 1/4	#1	12620J	100	1200
6 x 1 1/2	#1	12624J	100	1200
6 x 1 3/4	#1	12628J	100	600
6 x 2	#1	12632J	100	600
8 x 1/2**	#2	12808J	100	1200
8 x 5/8**	#2	12810J	100	1200
8 x 3/4**	#2	12812J	100	1200
8 x 1**	#2	12816J	100	1200
8 x 1 1/4	#2	12820J	100	1200
8 x 1 1/2	#2	12824J	100	1200
8 x 1 3/4	#2	12828J	100	600
8 x 2	#2	12832J	100	600
8 x 2 1/2	#2	12840J	100	600
8 x 3	#2	12848J	100	600
8 x 3 1/2	#2	12856J	100	600
8 x 4	#2	12864J	100	600
10 x 1/2**	#2	13008J	100	1200
10 x 3/4**	#2	13012J	100	1200
10 x 1**	#2	13016J	100	1200
10 x 1 1/4	#2	13020J	100	1200
10 x 1 1/2	#2	13024J	100	600
10 x 1 3/4	#2	13028J	100	600
10 x 2	#2	13032J	100	600
10 x 2 1/4	#2	13036J	100	600
10 x 2 1/2	#2	13040J	100	600
10 x 3	#2	13048J	100	600
10 x 3 1/2	#2	13056J	100	600
10 x 4	#2	13064J	100	600



**These sizes are fully threaded.

Continued on next page.

FLAT HEAD WOOD SCREWS • SQUARE DRIVE • ZINC (CONT.)



		Gravity Feed Jar		
Size	Driver Bit Size	Part #	Jar Qty	Master Carton
12 x 3/4**	#3	13212J	100	1200
12 x 1**	#3	13216J	100	1200
12 x 1 1/4	#3	13220J	100	600
12 x 1 1/2	#3	13224J	100	600
12 x 2	#3	13232J	100	600
12 x 2 1/2	#3	13240J	100	600
12 x 3	#3	13248J	100	600
12 x 3 1/2	#3	13256J	100	600
12 x 4	#3	13264J	100	600
14 x 3/4**	#3	13412J	100	1200
14 x 1**	#3	13416J	100	600
14 x 1 1/4	#3	13420J	100	600
14 x 1 1/2	#3	13424J	100	600
14 x 2	#3	13432J	100	600
14 x 2 1/2	#3	13440J	100	600
14 x 3 1/2	#3	13456J	100	600
14 x 4	#3	13464J	100	600

**These sizes are fully threaded.

		Kits			
Part #	Description				
39554 (316 Piece Kit)	#8 Flat Head Wood Screw Kit Includes a #2-2" Power Bit				
	8 x 1/2" (100 Pieces)	8 x 1" (50 Pieces)	8 x 1 1/2" (35 Pieces)		
	8 x 3/4" (60 Pieces)	8 x 1 1/4" (40 Pieces)	8 x 2" (30 Pieces)		
39555 (231 Piece Kit)	#10 Flat Head Wood Screw Kit Includes a #2-2" Power Bit				
	10 x 1/2" (70 Pieces)	10 x 1" (35 Pieces)	10 x 1 1/2" (25 Pieces)		
	10 x 3/4" (50 Pieces)	10 x 1 1/4" (30 Pieces)	10 x 2" (20 Pieces)		

TRIM HEAD WOOD SCREWS • SQUARE DRIVE • BLACK FINISH

		Gravity Feed Jar			1lb Boxes	
Size	Driver Bit Size	Part #	Jar Qty	Master Carton	Part #	Box Qty
6 x 1	#1	13716J	100	1200	137161lb	418
6 x 1 ⁵ / ₈	#1	13726J	100	1200	137261lb	242
6 x 2 ¹ / ₄	#1	13736J	100	600	137361lb	187
8 x 3	#2	13748J	100	600	137481lb	97

Quantities for 1lb boxes are approximate.



See page 252 for
Stainless Steel.

FASTENERS • SCREWS

DEEP THREAD FLAT HEAD PARTICLE BOARD SCREWS • SQUARE DRIVE • ZINC

Deep thread particle board screws are characterized by wider-spaced threads set deeper than a typical wood screw.

- #8 and #10 particle board screws require a #2 square drive bit.

		Gravity Feed Jar		
Size	Driver Bit Size	Part #	Jar Qty	Master Carton
8 x 3/4	#2	13814J	100	1200
8 x 1	#2	13815J	100	1200
8 x 1 1/4	#2	13822J	100	1200
8 x 1 1/2	#2	13826J	100	1200
8 x 1 3/4	#2	13830J	100	600
8 x 2	#2	13834J	100	600
8 x 2 1/4	#2	13838J	100	600
8 x 2 1/2	#2	13842J	100	600
8 x 3	#2	13850J	100	600
10 x 1 1/4	#2	14022J	100	1200
10 x 1 1/2	#2	14026J	100	600
10 x 1 3/4	#2	14030J	100	600
10 x 2 1/4	#2	14038J	100	600

Continued on next page.



DEEP THREAD FLAT HEAD PARTICLE BOARD SCREWS • SQUARE DRIVE • ZINC (CONT.)



Kits

Part #	Description			
39548 (241 Piece Kit)	#8 Deep Thread Particle Board Square Drive Screw Kit			
	Includes a #2-2" Power Bit			
	8 x 1/2" (60 Pieces)	8 x 1/4" (40 Pieces)	8 x 1 3/4" (30 Pieces)	8 x 2" (30 Pieces)
	8 x 1" (50 Pieces)	8 x 1 1/2" (30 Pieces)		

DEEP THREAD FLAT HEAD PARTICLE BOARD SCREWS • SQUARE DRIVE • BLACK



Gravity Feed Jar

Size	Driver Bit Size	Part #	Jar Qty	Master Carton
6 x 1	#1	13616J	100	1200
6 x 1 1/2	#1	13624J	100	1200
6 x 2	#1	13632J	100	600
8 x 3/4	#2	13812J	100	1200
8 x 1	#2	13816J	100	1200
8 x 1 1/4	#2	13820J	100	1200
8 x 1 1/2	#2	13824J	100	1200
8 x 1 3/4	#2	13828J	100	600
8 x 2	#2	13832J	100	600
8 x 2 1/4	#2	13836J	100	600
8 x 2 1/2	#2	13840J	100	600
8 x 3	#2	13848J	100	600
10 x 1	#2	14016J	100	1200
10 x 1 1/4	#2	14020J	100	1200
10 x 1 1/2	#2	14024J	100	600
10 x 1 3/4	#2	14028J	100	600
10 x 2	#2	14032J	100	600
10 x 2 1/4	#2	14036J	100	600
10 x 2 1/2	#2	14040J	100	600
10 x 3	#2	14048J	100	600

FINE THREAD BUGLE HEAD DRYWALL SCREWS • PHILLIPS • BLACK

- Ideal for metal stud applications up to 20 gauge.
- Symmetrical thread.

		Gravity Feed Jar			Job Jar	
Size	Driver Bit Size	Part #	Jar Qty	Master Carton	Part #	Jar Qty
6 x 1	#2	79616J	100	1200	—	
6 x 1 $\frac{1}{8}$	#2	79618J	100	1200	—	
6 x 1 $\frac{1}{4}$	#2	79624J	100	1200	79624-6	500
6 x 1 $\frac{5}{8}$	#2	79626J	100	1200	79626-6	500
6 x 2	#2	79632J	100	600	79632-6	350
6 x 2 $\frac{1}{4}$	#2	79636J	100	600	—	
8 x 2 $\frac{1}{2}$	#2	79840J	100	600	—	
8 x 3	#2	79848J	100	600	—	
10 x 4	#2	79964J	100	600	—	
10 x 4 $\frac{1}{2}$	#2	79972J	100	600	—	
10 x 5	#2	79980*	100	1000	—	

*These items are packaged in cardboard boxes.



FINE THREAD BUGLE HEAD DRYWALL TEK SCREWS • PHILLIPS • BLACK

- #6 Tek has a #1 point.
- #8 Tek has a #2 point.
- Ideal for metal studs up to 12 gauge.

		Gravity Feed Jar		
Size	Driver Bit Size	Part #	Jar Qty	Master Carton
6 x 1 $\frac{1}{4}$	#2	79623J	100	1200
6 x 1 $\frac{5}{8}$	#2	79627J	100	1200
6 x 1 $\frac{7}{8}$	#2	79630J	100	1200
8 x 2 $\frac{5}{8}$	#2	79845J	100	600
8 x 3	#2	79850J	100	600



COARSE THREAD BUGLE HEAD DRYWALL SCREWS • PHILLIPS • BLACK



FASTENERS • SCREWS

		Gravity Feed Jar			Job Jar	
Size	Driver Bit Size	Part #	Jar Qty	Master Carton	Part #	Jar Qty
6 x 1	#2	79617J	100	1200	—	—
6 x 1½	#2	79619J	100	1200	—	—
6 x 1¼	#2	79625J	100	1200	79625-6	500
6 x 1⅝	#2	79628J	100	1200	79628-6	500
6 x 2	#2	79634J	100	600	79634-6	350
8 x 2½	#2	79841J	100	600	—	—
8 x 3	#2	79849J	100	600	—	—

Kits			
Part #	Description		
39564 (221 Piece Kit)	Black Coarse Drywall Phillips Screw Kit		
	Includes a #2-2" Power Bit		
	6 x 1¼" (100 Pieces)	6 x 1⅝" (70 Pieces)	6 x 2" (50 Pieces)

COARSE THREAD BUGLE HEAD DRYWALL SCREWS • PHILLIPS • YELLOW ZINC



		Gravity Feed Jar			Job Jar	
Size	Driver Bit Size	Part #	Jar Qty	Master Carton	Part #	Jar Qty
6 x 1	#2	79620J	100	1200	79620-6	500
6 x 1¼	#2	79622J	100	1200	79622-6	500
6 x 1⅝	#2	79629J	100	1200	79629-6	500
6 x 2	#2	79635J	100	600	79635-6	350
6 x 2¼	#2	79637J	100	600	79637-6	250
8 x 2½	#2	79843J	100	600	79843-6	250
8 x 3	#2	79851J	100	600	79851-6	150
10 x 4	#2	79965J	100	600	—	—
10 x 5	#2	79981*	100	1000	—	—
10 x 6	#2	79997*	100	1000	—	—

*These items are packaged in cardboard boxes.

Kits			
Part #	Description		
39563 (221 Piece Kit)	Yellow Zinc Drywall Phillips Screw Kit		
	Includes a #2-2" Power Bit		
	6 x 1¼" (100 Pieces)	6 x 1⅝" (70 Pieces)	6 x 2" (50 Pieces)

ROUND & FLAT HEAD BRASS MACHINE SCREWS • SLOTTED

Round Head	Gravity Feed Jar		
Size	Part #	Jar Qty	Master Carton
6-32 x 1/2	51208J	100	1200
6-32 x 3/4	51212J	100	1200
6-32 x 1	51216J	100	1200
8-32 x 3/4	51412J	100	1200
8-32 x 1	51416J	100	1200
8-32 x 1 1/4	51420J	100	1200
8-32 x 1 1/2	51424J	100	1200
8-32 x 2	51432J	100	600
10-24 x 3/4	51512J	100	1200
10-24 x 1	51516J	100	1200
10-24 x 1 1/4	51520J	100	1200
10-24 x 1 1/2	51524J	100	600
10-24 x 2	51532J	100	600
10-32 x 3/8	51706J	100	1200
10-32 x 1/2	51708J	100	1200
10-32 x 3/4	51712J	100	1200
10-32 x 1	51716J	100	1200
10-32 x 1 1/4	51720J	100	1200
10-32 x 1 1/2	51724J	100	600
1/4-20 x 3/8	51806J	100	1200
1/4-20 x 1/2	51808J	100	1200
1/4-20 x 3/4	51812J	100	1200
1/4-20 x 1	51816J	100	600
1/4-20 x 1 1/4	51820J	100	600
1/4-20 x 1 1/2	51824J	100	600
1/4-20 x 2	51832J	100	600

Harsh Environment Product

Flat Head	Gravity Feed Jar		
Size	Part #	Jar Qty	Master Carton
6-32 x 1/2	56108J	100	1200
6-32 x 3/4	56112J	100	1200
6-32 x 1	56116J	100	1200
8-32 x 3/4	56312J	100	1200
8-32 x 1	56316J	100	1200
8-32 x 1 1/4	56320J	100	1200
8-32 x 1 1/2	56324J	100	1200

Harsh Environment Product



See page 243 for
Stainless Steel.



See page 245 for
Stainless Steel.

SCREW HOOKS • ZINC



						Gravity Feed Jar		
Size	Wire Diameter	Overall Length	Proj. Length	Wire Gauge	Hook Opening	Part #	Jar Qty	Master Carton
0	3/8	4 5/16	3 1/16	0	1 1/32	65000J	25	150
2	2 1/64	4 7/16	3 3/16	2	1	65002J	25	150
4	1 7/64	3 7/8	2 5/8	4	27/32	65004J	25	150
6	1 5/64	3 3/8	2 1/8	6	25/32	65006J	100	600
8	3/16	2 9/16	1 11/16	8	17/32	65008J	100	600
10	1 1/64	2 1/16	1 3/8	10	13/32	65010J	100	1200
12	1/8	1 1/16	1 11/16	12	9/32	65012J	100	1200

SCREW EYES • ZINC



						Gravity Feed Jar		
Size	Wire Diameter	Overall Length	Shank Length	Wire Gauge	Inside Eye Dia.	Part #	Jar Qty	Master Carton
0	5/16	3 3/16	1 9/16	0	13/16	66400J	50	300
2	1 7/64	2 11/16	1 13/32	2	23/32	66402J	50	300
4	1 7/64	2 3/16	1 1/8	4	39/64	66404J	50	300
6	1 5/64	1 15/16	31/32	6	17/32	66406J	100	600
8	3/16	1 5/8	13/16	8	15/32	66408J	100	600
10	1 1/64	1 3/8	1 1/16	10	13/32	66410J	100	1200
12	1/8	1 3/16	35/64	12	3/8	66412J	100	1200
14	3/32	1 1/16	1/2	14	11/32	66414J	100	1200

SCREW EYE LAGS • ZINC

					Gravity Feed Jar		
Thread Diameter	Overall Length	Shank Length	Thread Length	Inside Eye Diameter	Part #	Jar Qty	Master Carton
1/4	3 3/4	2 3/4	1 5/16	1/2	66466J ★	100	600
1/4	5	4	1 7/8	1/2	66467J ★	50	300

★ Made in USA



FASTENERS • SCREWS

ACOUSTICAL EYE LAGS & ACOUSTICAL EYE TEKS • ZINC

- Eye lags install easily with the acoustical eye teks.
- For use with tie wire, ceiling wire, and jack chain applications.

		Gravity Feed Jar		
Size	Application	Part #	Jar Qty	Master Carton
1/4 x 3	Wood	59248J	100	600
1/4 x 4	Wood	59264*	100	1000
1/4 x 5	Wood	59280*	100	1000
1/4 x 2	Metal*	59251J	100	600

*These items are packaged in cardboard boxes.

*Acoustical Eye Tek



Teks

Lag

Acoustical Eye Driver

Installs Eye Lags & Eye Tek



Size	Part #	Box Qty
Heavy Duty	59250	1

EYE BOLTS WITH HEX NUTS • ZINC



Gravity Feed Jar

Size	Overall Length	Thread Size	Thread Length	Shank Length	Inside Eye Diameter	Part #	Jar Qty	Master Carton
3/16	1 1/2	10-24	25/32	7/8	3/8	64024J	100	600
3/16	2	10-24	1	1 3/8	3/8	64032J	100	600
3/16	2 1/4	10-24	1 5/8	1 3/4	3/8	64040J	100	600
3/16	3	10-24	2 1/8	2 1/4	3/8	64048J	50	300
1/4	2	1/4-20	7/8	1	9/16	64132J	100	600
1/4	2 1/2	1/4-20	1 3/8	1 1/2	9/16	64140J	100	600
1/4	3	1/4-20	1 3/4	2	9/16	64148J	100	600
1/4	4	1/4-20	2 3/4	3	9/16	64164J	50	300
1/4	5	1/4-20	3	4	9/16	64180J	50	300
5/16	3 1/4	5/16-18	1 3/4	2	3/4	64252J	25	150
5/16	4	5/16-18	2 1/4	2 1/2	3/4	64264J	25	150
5/16	5	5/16-18	3	3 1/2	3/4	64280J	25	150
3/8	4	3/8-16	2	2 1/4	1	64364J	25	150
3/8	5	3/8-16	3	3 1/4	1	64380J	25	150
3/8	6	3/8-16	4	4 1/4	1	64396J	25	150
3/8	8	3/8-16	4	6 1/4	1	64399*	20	20
1/2	6	1/2-13	3	3 3/4	1 1/4	64496*	10	100
1/2	8	1/2-13	3	5 3/4	1 1/4	64499*	10	100
1/2	10	1/2-13	3	7 3/4	1 1/4	64510*	10	10
1/2	12	1/2-13	3	9 3/4	1 1/4	64512*	10	10

*These sizes are fully threaded.

U-BOLTS • ZINC • NUTS & PLATES INCLUDED



Fits Pipe Size	Height	Width Between Legs	Thread Length	Thread Size	Part #	Qty
2	5	2 3/8	3	5/16-18	67005	1
2	7	2 3/8	3	5/16-18	67007	1
2	9	2 3/8	3	5/16-18	67009	1

HEX HEAD LAG SCREWS • ZINC PLATED

 Gravity Feed Jar			
Size	Part #	Jar Qty	Master Carton
1/4 X 1	57016J	100	600
1/4 X 1 1/4	57020J	100	600
1/4 X 1 1/2	57024J	100	600
1/4 X 2	57032J	100	600
1/4 X 2 1/2	57040J	100	600
1/4 X 3	57048J	100	600
1/4 X 3 1/2	57056J	100	600
1/4 X 4	57064J	100	600
5/16 X 1	57216J	100	600
5/16 X 1 1/4	57220J	100	600
5/16 X 1 1/2	57224J	100	600
5/16 X 2	57232J	100	600
5/16 X 2 1/2	57240J	100	600
5/16 X 3	57248J	50	300
5/16 X 3 1/2	57256J	50	300
5/16 X 4	57264J	50	300
3/8 X 1	57416J	100	600
3/8 X 1 1/4	57420J	100	600
3/8 X 1 1/2	57424J	100	600
3/8 X 2	57432J	100	600
3/8 X 2 1/2	57440J	50	300
3/8 X 3	57448J	50	300
3/8 X 3 1/2	57456J	50	300
3/8 X 4	57464J	50	300
3/8 X 4 1/2	57472J	50	300
3/8 X 5	57480J	50	300
3/8 X 5 1/2	57488*	50	500
3/8 X 6	57496*	50	500
1/2 X 1 1/2	57824J	50	300
1/2 X 2	57832J	50	300
1/2 X 2 1/2	57840J	50	300
1/2 X 3	57848J	50	300
1/2 X 3 1/2	57856J	25	150
1/2 X 4	57864J	25	150
1/2 X 4 1/2	57872*	25	250
1/2 X 5	57880*	25	250
1/2 X 5 1/2	57888*	25	250
1/2 X 6	57896*	25	250



See pages
230-233 for
Stainless Steel.

FASTENERS • BOLTS

*These items are packaged in cardboard boxes.

CARRIAGE BOLTS • ZINC PLATED



See page 238 for
Stainless Steel.

Gravity Feed Jar

Size	Part #	Jar Qty	Master Carton
1/4-20 x 3/4	55112J	100	600
1/4-20 x 1	55116J	100	600
1/4-20 x 1 1/4	55120J	100	600
1/4-20 x 1 1/2	55124J	100	600
1/4-20 x 2	55132J	100	600
1/4-20 x 2 1/2	55140J	100	600
1/4-20 x 3	55148J	100	600
1/4-20 x 3 1/2	55156J	100	600
1/4-20 x 4	55164J	100	600
5/16-18 x 3/4	55312J	100	600
5/16-18 x 1	55316J	100	600
5/16-18 x 1 1/4	55320J	100	600
5/16-18 x 1 1/2	55324J	100	600
5/16-18 x 2	55332J	100	600
5/16-18 x 2 1/2	55340J	100	600
5/16-18 x 3	55348J	50	300
5/16-18 x 3 1/2	55356J	50	300
5/16-18 x 4	55364J	50	300
3/8-16 x 3/4	55512J	100	600
3/8-16 x 1	55516J	100	600
3/8-16 x 1 1/4	55520J	100	600
3/8-16 x 1 1/2	55524J	50	300
3/8-16 x 2	55532J	50	300
3/8-16 x 2 1/2	55540J	50	300
3/8-16 x 3	55548J	25	150
3/8-16 x 3 1/2	55556J	25	150
3/8-16 x 4	55564J	25	150

GRADE 2 FULLY THREADED MACHINE TAP BOLTS • ZINC

	 Gravity Feed Jar		
Size	Part #	Jar Qty	Master Carton
1/4-20 x 1 1/4	55022J	100	600
1/4-20 x 1 1/2	55026J	100	600
1/4-20 x 2	55034J	100	600
1/4-20 x 2 1/2	55035J	100	600
1/4-20 x 3	55050J	100	600
5/16-18 x 1	55216J	100	600
5/16-18 x 1 1/2	55227J	100	600
5/16-18 x 2	55234J	100	600
5/16-18 x 2 1/2	55242J	100	600
3/8-16 x 1 1/4	55422J	100	600
3/8-16 x 2	55434J	100	600
3/8-16 x 2 1/2	55442J	50	300
3/8-16 x 3	55450J	50	300
1/2-13 x 1	55816J	50	300
1/2-13 x 1 1/4	55820J	50	300
1/2-13 x 1 1/2	55826J	50	300
1/2-13 x 2	55834J	50	300
1/2-13 x 2 1/2	55842J	50	300
1/2-13 x 3	55850J	50	300



FASTENERS • BOLTS

GRADE 2 HEX HEAD MACHINE BOLTS • ZINC



Partially Threaded

- 1", ¾" and ½" are fully threaded.
- No markings and made of low grade carbon steel.



Gravity Feed Jar

Size	Part #	Jar Qty	Master Carton
¼-20 x ½	55008J	100	1200
¼-20 x ¾	55012J	100	600
¼-20 x 1	55016J	100	600
¼-20 x 1¼	55020J	100	600
¼-20 x 1½	55024J	100	600
¼-20 x 2	55032J	100	600
¼-20 x 2½	55040J	100	600
¼-20 x 3	55048J	100	600
¼-20 x 3½	55056J	50	300
¼-20 x 4	55064J	50	300
5/16-18 x ½	55208J	100	600
5/16-18 x ¾	55212J	100	600
5/16-18 x 1	55216J	100	600
5/16-18 x 1¼	55220J	100	600
5/16-18 x 1½	55224J	100	600
5/16-18 x 2	55232J	100	600
5/16-18 x 2½	55240J	100	600
5/16-18 x 3	55248J	100	600
5/16-18 x 3½	55256J	50	300
5/16-18 x 4	55264J	50	300
3/8-16 x ½	55408J	100	600
3/8-16 x ¾	55412J	100	600
3/8-16 x 1	55416J	100	600
3/8-16 x 1¼	55420J	100	600
3/8-16 x 1½	55424J	100	600
3/8-16 x 2	55432J	100	600
3/8-16 x 2½	55440J	50	300
3/8-16 x 3	55448J	50	300
3/8-16 x 3½	55456J	50	300
3/8-16 x 4	55464J	50	300
½-13 x ¾	55812J	50	300
½-13 x 1	55816J	50	300
½-13 x 1¼	55820J	50	300
½-13 x 1½	55824J	50	300
½-13 x 2	55832J	50	300
½-13 x 2½	55840J	50	300
½-13 x 3	55848J	50	300
½-13 x 3½	55856J	25	150
½-13 x 4	55864J	25	150

GRADE 5 HEX HEAD BOLTS • ZINC

- Has three hash marks and made of medium carbon steel—quenched and tempered.
- See Grade 5 Hex Nuts on page 57.
- Fully threaded.



Gravity Feed Jar

Size	Part #	USA Part #	Jar Qty	Master Carton
1/4-20 x 1/2	55009J	55009USJ ★	100	1200
1/4-20 x 3/4	55013J	55013USJ ★	100	600
1/4-20 x 1	55017J	55017USJ ★	100	600
1/4-20 x 1 1/4	55021J	55021USJ ★	100	600
1/4-20 x 1 1/2	55025J	55025USJ ★	100	600
1/4-20 x 2	55033J	55033USJ ★	100	600
1/4-20 x 2 1/2	55041J	55041USJ ★	100	600
1/4-20 x 3	55049J	55049USJ ★	100	600
5/16-18 x 1/2	55209J	55209USJ ★	100	600
5/16-18 x 3/4	55213J	55213USJ ★	100	600
5/16-18 x 1	55217J	55217USJ ★	100	600
5/16-18 x 1 1/4	55221J	55221USJ ★	100	600
5/16-18 x 1 1/2	55225J	55225USJ ★	100	600
5/16-18 x 2	55233J	55233USJ ★	100	600
5/16-18 x 2 1/2	55241J	55241USJ ★	100	600
3/8-16 x 1/2	55409J	55409USJ ★	100	600
3/8-16 x 3/4	55413J	55413USJ ★	100	600
3/8-16 x 1	55417J	55417USJ ★	100	600
3/8-16 x 1 1/4	55421J	55421USJ ★	100	600
3/8-16 x 1 1/2	55425J	55425USJ ★	100	600
3/8-16 x 2	55433J	55433USJ ★	100	600
3/8-16 x 2 1/2	55441J	55441USJ ★	50	300
3/8-16 x 3	55449J	55449USJ ★	50	300
1/2-13 x 3/4	55813J	55813USJ ★	100	600
1/2-13 x 1	55817J	55817USJ ★	50	300
1/2-13 x 1 1/4	55821J	55821USJ ★	50	300
1/2-13 x 1 1/2	55825J	55825USJ ★	50	300
1/2-13 x 2	55833J	55833USJ ★	50	300
1/2-13 x 2 1/2	55841J	55841USJ ★	50	300
1/2-13 x 3	55849J	55849USJ ★	50	300

★ Made in USA

HEX HEAD BOLTS • SILICON BRONZE



FASTENERS • BOLTS

See page
234-237 for
Stainless Steel.

See page 62
for Silicon
Bronze Split
Lock Washers.

Size	Part #	Gravity Feed Jar	
		Jar Qty	Master Carton
1/4-20 x 1/2	54108J	100	1200
1/4-20 x 5/8	54110J	100	600
1/4-20 x 3/4	54112J	100	600
1/4-20 x 1	54116J	100	600
1/4-20 x 1 1/4	54120J	100	600
1/4-20 x 1 1/2	54124J	100	600
1/4-20 x 2	54132J	100	600
5/16-18 x 1/2	54208J	100	600
5/16-18 x 3/4	54212J	100	600
5/16-18 x 1	54216J	100	600
5/16-18 x 1 1/4	54220J	100	600
5/16-18 x 1 1/2	54224J	100	600
5/16-18 x 2	54232J	100	600
3/8-16 x 1/2	54408J	100	600
3/8-16 x 3/4	54412J	100	600
3/8-16 x 1	54416J	100	600
3/8-16 x 1 1/4	54420J	100	600
3/8-16 x 1 1/2	54424J	100	600
3/8-16 x 2	54432J	100	600
3/8-16 x 2 1/2	54440J	50	300
3/8-16 x 3	54448J	50	300
3/8-16 x 3 1/2	54456J	50	300
3/8-16 x 4	54464J	50	300
1/2-13 x 3/4	54812J	50	300
1/2-13 x 1	54816J	50	300
1/2-13 x 1 1/4	54820J	50	300
1/2-13 x 1 1/2	54824J	50	300
1/2-13 x 1 3/4	54828J	50	300
1/2-13 x 2	54832J	50	300
1/2-13 x 2 1/2	54840J	50	300
1/2-13 x 3	54848J	50	300
1/2-13 x 3 1/2	54856J	25	150
1/2-13 x 4	54864J	25	150

Harsh Environment Product

HEX NUTS • ZINC PLATED

Size	Gravity Feed Jar			Job Jar	
	Part #	Jar Qty	Master Carton	Part #	Jar Qty
4-40	40103J	100	1200	—	
6-32	40105J	100	1200	—	
8-32	40110J	100	1200	—	
10-24	40115J	100	1200	—	
10-32	40120J	100	1200	—	
12-24	40122J	100	1200	—	
¼-20	40125J	100	1200	40125-6	750
¼-28	40126J	100	1200	—	
⅝-18	40130J	100	1200	—	
⅜-16	40135J	100	600	40135-6	250
⅞-14	40137J	100	600	—	
½-13	40140J	100	600	40140-6	150
⅝-11	40145J	50	300	—	
¾-10	40150J	50	300	—	
1-8	40155J	10	60	—	



See page 224 for
Stainless Steel.

FASTENERS • NUTS/WASHERS

Kits					
Part #	Description				
39516 (405 Piece Kit)	Hex Nut Zinc Plated Kit				
	6-32 (100 Pieces)	8-32 (100 Pieces)	10-32 (100 Pieces)		
	¼-20 (50 Pieces)	⅝-18 (35 Pieces)	⅜-16 (20 Pieces)		

HEX NUTS • HEAVY DUTY • ZINC PLATED

Size	Gravity Feed Jar		
	HEAVY DUTY		
	Part #	Jar Qty	Master Carton
⅝-16	40135HJ	100	600
½-13	40140HJ	100	600
¾-10	40150HJ	50	300



HEX NUTS • BRASS



See page 224 for
Stainless Steel.

	Gravity Feed Jar		
Size	Part #	Jar Qty	Master Carton
6-32	43105J	100	1200
8-32	43110J	100	1200
10-24	43115J	100	1200
10-32	43120J	100	1200
12-24	43122J	100	1200
1/4-20	43125J	100	1200
5/16-18	43130J	100	1200
3/8-16	43135J	100	600
1/2-13	43140J	100	600

Harsh Environment Product

FASTENERS • NUTS/WASHERS

HEX NUTS • SILICON BRONZE



See page 224 for
Stainless Steel.

	Gravity Feed Jar		
Size	Part #	Jar Qty	Master Carton
8-32	41110J	100	1200
10-24	41115J	100	1200
10-32	41120J	100	1200
12-24	41122J	100	1200
1/4-20	41125J	100	1200
5/16-18	41130J	100	1200
3/8-16	41135J	100	600
1/2-13	41140J	100	600
5/8-11	41145J	50	300

Harsh Environment Product

FLANGE WHIZ NUTS • ZINC

Gravity Feed Jar			
Size	Part #	Jar Qty	Master Carton
1/4-20	40480J	100	1200
5/16-18	40481J	100	1200
3/8-16	40482J	100	600
1/2-13	40483J	100	600



GRADE 5 HEX NUTS

Gravity Feed Jar				
Size	Part #	U.S. Part #	Jar Qty	Master Carton
1/4-20	40225J	40225USJ ★	100	1200
5/16-18	40230J	40230USJ ★	100	1200
3/8-16	40235J	40235USJ ★	100	600
1/2-13	40240J	40240USJ ★	50	600
3/4-10	40250J	40250USJ ★	50	300



★ Made in USA

NYLOCK HEX NUTS

Gravity Feed Jar			
Size	Part #	Jar Qty	Master Carton
4-40	40402J	100	1200
6-32	40405J	100	1200
8-32	40411J	100	1200
10-32	40416J	100	1200
10-24	40420J	100	1200
1/4-20	40425J	100	1200
5/16-18	40430J	100	1200
3/8-16	40435J	100	600
1/2-13	40440J	100	600



See page 225 for
Stainless Steel.

SPECIALTY NUTS • CAP NUTS • NICKEL PLATED



 Gravity Feed Jar

Size	Part #	Jar Qty	Master Carton
8-32	41310J	100	1200
10-24	41315J	100	1200
10-32	41320J	100	1200
1/4-20	41325J	100	1200
5/16-18	41331J	100	600
3/8-16	41336J	100	600
1/2-13	41341J	100	600

SPECIALTY NUTS • WING NUTS



 Gravity Feed Jar

Size	Part #	Jar Qty	Master Carton
10-24	41415J	100	1200
10-32	41420J	100	1200
1/4-20	41425J	100	1200
5/8-18	41430J	100	600
3/8-16	41435J	100	600

FLAT CUT WASHERS • ZINC PLATED

Size	Gravity Feed Jar			Job Jar	
	Part #	Jar Qty	Master Carton	Part #	Jar Qty
#6	40305J*	100	1200	—	—
#8	40310J*	100	1200	—	—
#10	40315J	100	1200	—	—
#12	40317J	100	1200	—	—
1/4"	40325J	100	1200	40325-6	1000
5/16"	40330J	100	1200	—	—
3/8"	40335J	100	600	40335-6	250
1/2"	40340J	100	600	40340-6	150
5/8"	40345J	100	600	—	—
3/4"	40350J	100	600	—	—



See page 226 for
Stainless Steel.

*These sizes fall within the SAE specifications.

SAE	Gravity Feed Jar		
Size	Part #	Jar Qty	Master Carton
1/4"	40326SAEJ	100	1200
5/16"	40330SAEJ	100	1200
3/8"	40336SAEJ	100	1200
1/2"	40340SAEJ	100	600









Kits	
Part #	Description
39518 (370 Pc Kit)	Flat Cut Washer Kit #8 (100 Pieces) 1/4" (100 Pieces)
	#10 (100 Pieces) 5/16" (35 Pieces)
	3/8" (35 Pieces)

FASTENERS • NUTS/WASHERS

FLAT CUT WASHERS • SILICON BRONZE



See page 226 for
Stainless Steel.











 Gravity Feed Jar			
Size	Part #	Jar Qty	Master Carton
#8	42310J 	100	1200
#10	42315J 	100	1200
1/4"	42325J 	100	1200
5/16"	42330J 	100	1200
3/8"	42335J 	100	600
1/2"	42340J 	100	600
5/8"	42345J 	100	600
3/4"	42350J 	100	600

 Harsh Environment Product

FLAT CUT WASHERS • BRASS



See page 226 for
Stainless Steel.

 Gravity Feed Jar			
Size	Part #	Jar Qty	Master Carton
#6	43305J 	100	1200
#8	43310J 	100	1200
#10	43315J 	100	1200
#12	43320J 	100	1200
1/4"	43325J 	100	1200
5/16"	43330J 	100	1200
3/8"	43335J 	100	1200
1/2"	43340J 	100	600
5/8"	43345J 	100	600
3/4"	43350J 	100	600

 Harsh Environment Product

FENDER WASHERS • ZINC PLATED

Size	Gravity Feed Jar			Job Jar	
	Part #	Jar Qty	Master Carton	Part #	Jar Qty
1/8 x 1"	40705J	100	1200	—	—
3/16 x 1"	40709J	100	1200	—	—
3/16 x 1 1/8"	40710J	100	1200	—	—
3/16 x 1 1/4"	40715J	100	1200	—	—
1/4 x 1"	40720J	100	1200	40720-6	350
1/4 x 1 1/4"	40725J	100	600	40725-6	250
1/4 x 1 1/2"	40730J	100	600	40730-6	250
1/4 x 2"	40733J	100	600	—	—
5/16 x 1 1/4"	40735J	100	600	—	—
5/16 x 1 1/2"	40740J	100	600	—	—
3/8 x 1"	40741J	100	1200	—	—
3/8 x 1 1/4"	40743J	100	600	40743-6	250
3/8 x 1 1/2"	40745J	100	600	40745-6	250
3/8 x 2"	40747J	100	600	—	—
1/2 x 1 1/2"	40750J	100	600	—	—
1/2 x 2"	40755J	100	600	—	—



See page 228 for
Stainless Steel.

FASTENERS • NUTS/WASHERS

Kits			
Part #	Description		
39519 (120 Pc Kit)	Fender Washer Kit		
	3/16 x 1 1/4" (40 Pcs)	1/4 x 1 1/4" (40 Pcs)	3/8 x 1 1/4" (40 Pcs)

SPLIT LOCK WASHERS • ZINC PLATED



See page 227 for
Stainless Steel.

Gravity Feed Jar

Size	Part #	Jar Qty	Master Carton
#6	40505J	100	1200
#8	40510J	100	1200
#10	40515J	100	1200
#12	40517J	100	1200
1/4"	40525J	100	1200
5/16"	40530J	100	1200
3/8"	40535J	100	1200
1/2"	40540J	100	600
5/8"	40545J	100	600

Kits

Part #	Description
39517 (425 Piece Kit)	Split Lock Washer Kit
	#8 (100 Pieces) 1/4" (100 Pieces) 5/16" (60 Pieces)
	#10 (100 Pieces) 3/8" (40 Pieces) 1/2" (25 Pieces)

SPLIT LOCK WASHERS • SILICON BRONZE



See page 227 for
Stainless Steel.

Gravity Feed Jar

Size	Part #	Jar Qty	Master Carton
#6	42505J ♡	100	1200
#8	42510J ♡	100	1200
#10	42515J ♡	100	1200
#12	42517J ♡	100	1200
1/4"	42525J ♡	100	1200
5/16"	42530J ♡	100	1200
3/8"	42535J ♡	100	1200
1/2"	42540J ♡	100	600
5/8"	42545J ♡	100	600
3/4"	42550J ♡	100	600

♡ Harsh Environment Product

TOOTHED LOCK WASHERS • INTERNAL • ZINC PLATED

Gravity Feed Jar			
Size	Part #	Jar Qty	Master Carton
#6	40605J	100	1200
#8	40610J	100	1200
#10 ($\frac{3}{16}$)	40615J	100	1200
$\frac{1}{4}$	40620J	100	1200
$\frac{5}{16}$	40625J	100	1200



TOOTHED LOCK WASHERS • EXTERNAL • ZINC PLATED

Gravity Feed Jar			
Size	Part #	Jar Qty	Master Carton
#6	40606J	100	1200
#8	40611J	100	1200
#10 ($\frac{3}{16}$)	40616J	100	1200
$\frac{1}{4}$	40621J	100	1200
$\frac{5}{16}$	40626J	100	1200



See page 227 for Stainless Steel.

SPECIALTY WASHERS • SEALING WASHERS • GALVANIZED

Gravity Feed Jar			
Size	Part #	Jar Qty	Master Carton
#10	40410J	100	1200
#12	40412J	100	1200
$\frac{1}{4}$	40414J	100	1200



Galvanized with Rubber Washer.

SPECIALTY WASHERS • OCTAGONAL • ZINC

Gravity Feed Jar			
Size	Part #	Jar Qty	Master Carton
$\frac{1}{4} \times 1\frac{3}{8}$	40760J	100	600
$\frac{3}{8} \times 1\frac{3}{8}$	40762J	100	600

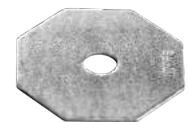

SPECIALTY WASHERS • BELLEVILLE • SPRING STEEL



See page 229 for
Stainless Steel.

		Gravity Feed Jar		
Size	Spring Force	Part #	Jar Qty	Master Carton
1/4	569#	40905J	100	1200
5/16	1682#	40910J	100	1200
3/8	1700#	40915J	100	1200
1/2	2337#	40925J	100	600

FINISH CUP WASHERS • BRASS



See page 229 for
Stainless Steel.

		Gravity Feed Jar		
Size	Part #	Jar Qty	Master Carton	
#6	43805J	100	1200	
#8	43810J	100	1200	
#10	43815J	100	1200	

Harsh Environment Product

GREEN GROUNDING SCREWS • ZINC

- Type C Point is also known as a pilot point or dog point.
- Type F Point is thread cutting.

			Gravity Feed Jar			Job Jar	
Size	Head Style	Point Type	Part #	Jar Qty	Master Carton	Part #	Jar Qty
10-32 x 3/8"	Hex Washer Head 5/16" Slot/Phil	Type F	80006J	100	1200	80006-6	1000
10-32 x 3/8"	Hex Washer Head Quad Drive	Type C	80022J	100	1200	—	—



GROUNDING PIGTAILS WITH GROUNDING SCREWS • QUAD DRIVE • INSULATED

				Plastic Bag	
Gauge	Length	Point Size	Lead Style	Part #	Qty
#12	6 1/2"	Solid	Bare Wire Lead	80007	50
#14	6 1/2"	Solid	Bare Wire Lead	80016	50
#12	7 1/2"	Solid	Bare Wire Lead	80018	50
#12	8"	Stranded	Forked Terminal	80015	50
#12	9"	Solid	Bare Wire Lead	80021	50
#12	10"	Solid	Bare Wire Lead	80020	50



GREEN GROUNDING CLIPS • GREEN ZINC CHROMATE

- Connects non-metallic sheathed cable grounding conductor to outlet boxes.
- Press onto top edge of box to hold grounding conductor against side wall.
- Designed to fit all common sizes of copper or aluminum wire.

		Gravity Feed Jar		
Gauge	Part #	Jar Qty	Master Carton	
Universal #10-12-14	80011J	100	1200	



CONDUIT HUBS • BRONZE



Description	Cardboard Box	
	Part #	Box Qty
1/2" Conduit Hub	95050	10
3/4" Conduit Hub	95052	10
1" Conduit Hub	95054	10

GROUND ROD CLAMPS • FOR DIRECT BURIAL • BRONZE

Harsh Environment Product



Description	Cardboard Box	
	Part #	Box Qty
1/2" Ground Rod Clamp with Stainless Screws	95070	10
5/8" Ground Rod Clamp with Stainless Screws	95072	10
3/4" Ground Rod Clamp with Stainless Screws	95074	10

GROUND CLAMPS • BRONZE

Harsh Environment Product

- Fits #2, 4, 6, 8 and 10 AWG copper.



Description	Hardware	Application	Cardboard Box	
			Part #	Box Qty
1/2" – 1" Pipe Ground Clamp	Zinc Plated Steel	Copper and Aluminum Wire	95150	10
1/2" – 1" Pipe Ground Clamp (Brass-Plated)	Zinc	Bare Wire – Non UL	95151	10
1/2" – 1" Pipe Ground Clamp	Zinc Plated Steel	Bare Wire	95152	10
1 1/4" – 2" Pipe Ground Clamp	Zinc Plated Steel	Bare Wire	95156	10
2 1/2" – 4" Pipe Ground Clamp	Zinc Plated Steel	Bare Wire	95158	10
1/2" – 1" Pipe Ground Clamp	Zinc Plated Steel	Direct Burial	95154	10

ARMORED GROUND CLAMPS • BRONZE

Harsh Environment Product



- Fits 4, 6 and 8 bare armored ground wire copper.

Description	Hardware	Cardboard Box	
		Part #	Box Qty
1/2" – 1" Armored Pipe Ground Clamp	Zinc Plated Steel	95168	10
1 1/4" – 2" Armored Pipe Ground Clamp	Zinc Plated Steel	95170	10

GROUND CLAMPS WITH THREADED HUBS • BRONZE

Harsh Environment Product



Description	Application	Cardboard Box	
		Part #	Box Qty
1/2" – 1" Ground Clamp with 1/2" Hub	For Conduit Pipe	95190	10
1/2" – 1" Ground Clamp with 3/4" Hub	For Conduit Pipe	95192	10
1/2" – 1" Ground Clamp with 1" Hub	For Conduit Pipe	95194	10

Harsh Environment Product

EZ ANCORS™ • #8 ZINC ALLOY • FULL SIZED

- A one-piece self-drilling anchor.

	Gravity Feed Jar		
Size	Part #	Jar Qty	Master Carton
#8 Zinc EZ Ancor <i>Screws not included.</i>	59510J ★	100	600

	Kits	Gravity Feed Jar	Job Jar
Description	Part #	Part #	Part #
#8 EZ Ancor Sq/Phil Kit			
EZ Ancors Zinc (50 Pieces)	39915	39915J	39915-6
#8 x 1¼ Sq/Phil Screws (50 Pieces)	(101 Piece Kit)	(101 Piece Kit)	(201 Piece Kit)
#2-2" Hex Power Bit (1 Piece)			
#8 EZ Ancor Phil/Slot Kit			
EZ Ancors Zinc (50 Pieces)	39916	39916J	39916-6
#8 x 1¼ Phil/Slot Screws (50 Pieces)	(101 Piece Kit)	(101 Piece Kit)	(201 Piece Kit)
★ Made in USA			
#2-2" Hex Power Bit (1 Piece)			



FASTENERS • ANCHORS

DOUBLE DRYWALL ANCHOR

- Works when penetrating wood stud behind drywall.
- No pre-drilling required.
- Quick and easy installation using a #2 Phillips.
- Up to 75lb load capacity when using 5/8" drywall.
- Easily removable.
- Not recommended for overhead use.

	Gravity Feed Jar	Kits	Job Jar
Description	Part #	Part #	Part #
Double Drywall Anchor (50 Pieces) Phillips			
#8 x 1¼ PHSMS (50 Pieces)	39940J	39940	39940-6
#2 Phillips Driver Bit (1 Piece)	(101 Piece Kit)	(101 Piece Kit)	(201 Piece Kit)

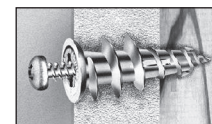

EZ ANCORS™ • #6–8 ZINC ALLOY • MINI

- A one-piece self-drilling anchor.



	Gravity Feed Jar		
Size	Part #	Jar Qty	Master Carton
#6-8 Zinc EZ Mini Ancor <i>Screws not included.</i>	59512J ★	100	600

- ★ Made in USA

Description	Kits Part #	Gravity Feed Jar Part #
EZ Mini Ancor Square/Phillips Kit		
EZ Mini Ancors Zinc (50 Pieces) #6 x 1" Sq/Phil Screws (50 Pieces) #2-2" Hex Power Bit (1 Piece)	39928 (101 Piece Kit)	39928J (101 Piece Kit)
EZ Mini Ancor Phillips/Slotted Kit		
EZ Mini Ancors Zinc (50 Pieces) #6 x 1" Phil/Slot Screws (50 Pieces) #2-2" Hex Power Bit (1 Piece)	39929 (101 Piece Kit)	39929J (101 Piece Kit)
EZ Mini Ancor Phillips Fine Thread		
EZ Mini Ancors Zinc (50 Pieces) #6 x 1" Phillips Fine Thread Drywall Screws (50 Pieces) #2-2" Hex Power Bit (1 Piece)	39932 (101 Piece Kit)	—

EZ ANCOR™ TRIPLE PACK • EZ ANCORS, EZ LITE, & EZ TOGGLE



- A one-piece self-drilling anchor.

Kits	
Part #	Description
39930 (131 Pc Kit)	EZ Triple Pack Sq/Phil Combo 35 EZ Ancors Lites w/35 Screws 10 EZ Toggles w/10 Screws 20 Zinc EZ Ancors w/20 Screws #2-2" Hex Power Bit

Kits	
Part #	Description
39931 (131 Pc Kit)	EZ Triple Pack Slot/Phil Combo 35 EZ Ancors Lites w/35 Screws 10 EZ Toggles w/10 Screws 20 Zinc EZ Ancors w/20 Screws #2-2" Hex Power Bit

Get the Assortment You Need with the Triple Pack!

EZ ANCORS™ #8 WHITE PLASTIC • FULL SIZED

- A one-piece self-drilling anchor.

	Gravity Feed Jar		
Size	Part #	Jar Qty	Master Carton
#8 Plastic EZ Ancor Screws <i>not included.</i>	59515J ★	100	600

★ Made in USA

	Kits	Gravity Feed Jar	Job Jar
Size	Part #	Part #	Part #
#8 EZ Ancor Sq/Phil Kit			
Plastic EZ Ancors (50 Pieces)	39920 ★ (101 Piece Kit)	39920J ★ (101 Piece Kit)	39920-6 ★ (201 Piece Kit)
#8 x 1" Sq/Phil Screws (50 Pieces)			
#2-2" Hex Power Bit (1 Piece)			
#8 EZ Ancor Slot/Phil Kit			
Plastic EZ Ancors (50 Pieces)	39921 ★ (101 Piece Kit)	39921J ★ (101 Piece Kit)	39921-6 ★ (201 Piece Kit)
#8 x 1" Slot/Phil Screws (50 Pieces)			
#2-2" Hex Power Bit (1 Piece)			

★ Made in USA

EZ ANCORS™ #6 WHITE PLASTIC LITE • LITE

- A one-piece self-drilling anchor.

	Gravity Feed Jar		
Size	Part #	Jar Qty	Master Carton
#6 Plastic Lite EZ Ancor Screws <i>not included.</i>	59522J ★	100	600

★ Made in USA

	Kits	Gravity Feed Jar
Description	Part #	Part #
#6 EZ Ancor Sq/Phil Kit		
Plastic EZ Ancors (50 Pieces)	39922 (101 Piece Kit)	39922J (101 Piece Kit)
#6 x 1" Sq/Phil Screws (50 Pieces)		
#1-2" Hex Power Bit (1 Piece)		
#6 EZ Ancor Slot/Phil Kit		
Plastic EZ Ancors (50 Pieces)	39923 (101 Piece Kit)	39923J (101 Piece Kit)
#6 x 1" Slot/Phil Screws (50 Pieces)		
#1-2" Hex Power Bit (1 Piece)		



TOGGLER® SNAPTOGGLE® TOGGLE BOLT ANCHORS • HIGH STRENGTH



Toggles Only			Cardboard Box	
Model	Screw Size	Drill Size	Part #	Box Qty
BA	10-24 (9/16)	1/2"	58732 ★	100
BB	1/4"-20 (1/4)	1/2"	58816 ★	100
BC	3/8"-16	3/4"	58900 ★	25

★ Made in USA

Mini Kits		Clam Shell	
Screw Size	Drill Size	Part #	Box Qty
10-24 x 2 Th Sq/Slot	1/2"	58742 ★	6
10-24 x 3 Th Sq/Slot	1/2"	58743 ★	6
10-24 x 4 Th Sq/Slot	1/2"	58744 ★	6
1/4"-20 x 3 Th Sq/Slot	1/2"	58817 ★	6
1/4"-20 x 4 Th Sq/Slot	1/2"	58818 ★	6

FASTENERS • ANCHORS ORS

Installation for Models BA & BB

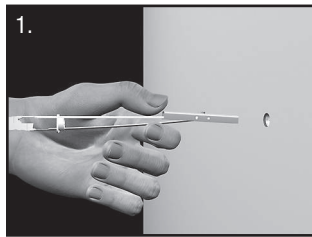

1. Drill 1/2" (Ø13mm) hole. Hold metal channel flat alongside plastic straps and slide channel through hole. Minimum clearance behind wall: 1 7/8" (48mm).

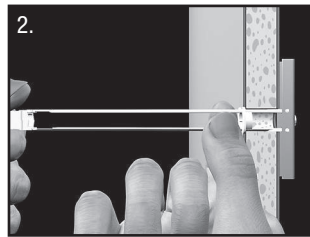

2. Hold ends of straps between thumb and forefinger and pull toward you until channel rests flush behind wall. Slide plastic cap along straps with other hand until flange of cap is flush with wall.

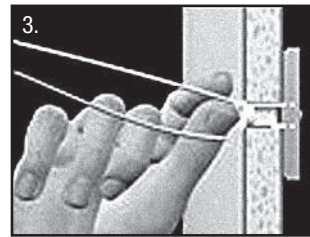

3. Snap straps at wall by pushing side to side, snapping off straps level with flange of cap.

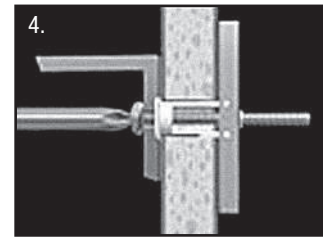

4. Place item over flange. Insert bolt through item and tighten until flush against item, then stop.

Use machine screw or bolt to match thread in channel: BA (3/16"-24), BB (1/4"-20).

Bolt length = item thickness + wall or ceiling thickness + 1/2" (13mm)

U.S. Patent No. 6,161,999 and foreign counterparts thereof and of 4,650,386. Other patents pending. TOGGLER and SNAPTOGGLE are worldwide registered trademarks of Mechanical Plastics Corp.

Ultimate Tensile Pull-Out Values (lb)

Anchor	UNC Thread	Drill Dia.	1/2" Drywall	5/8" Drywall	*1/2" and 25 Gauge Stud	*5/8" and 25 Gauge Stud	Concrete Block	1/2" Steel Plate	Stainless in 1/2" Steel ³
BA	3/16"-24	1/2"	238	356	412	462	802	918 ¹	1193 ¹
BB	1/4"-20	1/2"	265	356	425	464	1080	1288 ²	1735 ¹
BE	5/16"-18	3/4"	270	480	439	477	1400	1680	2118
BC	3/8"-16	3/4"	275	576	466	488	1745	1692	2523 ¹
BD	1/2"-13	3/4"	275	576	468	513	**2038 ²	2605	3150

* Failure measured as breakage of drywall portion

** Failure of block

¹ Stainless steel bolts used

² Hardened bolts used

³ Stainless steel channel tested with stainless bolts in 1/2" steel plate

Ultimate Shear (lb)

Anchor	UNC Thread	Drill Dia.	1/2" Drywall	5/8" Drywall
BA	3/16"-24	1/2"	247	298
BB	1/4"-20	1/2"	241	324
BC	3/8"-16	3/4"	292	406

TRUSS HEAD TOGGLE BOLTS & WINGS • SLOTTED/SQUARE • ZINC • WINGS INCL.

		Gravity Feed Jar		
Screw Size	Drill/Hole Diameter	Part #	Jar Qty	Master Carton
1/8 x 2	3/8	58132J	100	600
1/8 x 3	3/8	58148J	100	600
1/8 x 4	3/8	58164J	100	600
3/16 x 2	1/2	58332J	100	600
3/16 x 3	1/2	58348J	50	300
3/16 x 4	1/2	58364J	50	300
1/4 x 3	5/8	58548J	50	300
1/4 x 4	5/8	58564J	50	300



TRUSS HEAD TOGGLE BOLTS & WINGS • PHILLIPS/SLOTTED • ZINC • WINGS INCL.

		Gravity Feed Jar		
Screw Size	Drill/Hole Diameter	Part #	Jar Qty	Master Carton
1/8 x 2	3/8	58133J	100	600
1/8 x 3	3/8	58149J	100	600
1/8 x 4	3/8	58165J	50	300
3/16 x 2	1/2	58333J	100	600
3/16 x 3	1/2	58349J	50	300
3/16 x 4	1/2	58365J	50	300
1/4 x 3	5/8	58549J	50	300
1/4 x 4	5/8	58565J	50	300



ROUND HEAD TOGGLE BOLTS & WINGS • SLOTTED • ZINC • WINGS INCLUDED

		Gravity Feed Jar		
Screw Size	Drill/Hole Diameter	Part #	Jar Qty	Master Carton
3/16 x 6	1/2	58396J	50	300
1/4 x 6	5/8	58496J	50	300
5/16 x 3	7/8	58647J	50	300
3/8 x 3	1	58648J	25	150
3/8 x 4	1	58664J	25	150
3/8 x 5	1	58680J	20	120
3/8 x 6	1	58696J	20	120



FAS' FASTENERS • ANCHORS

TOGGLE BOLT WINGS • SPRING LOADED • ZINC



Gravity Feed Jar			
Size	Part #	Jar Qty	Master Carton
1/8	58031J	100	600
3/16	58231J	100	600
1/4-20	58431J	100	600
5/16-18	58531J	100	600
3/8-16	58631J	100	600

HOLLOW WALL ANCHORS • COMBO PHILLIPS/SLOTTED SCREW • ZINC



					Gravity Feed Jar		
Thread Size	Hex Length	Sleeve Length	Drill Size	Wall Thickness	Part #	Jar Qty	Master Carton
1/8	Extra Short	1 1/16	1/4	1/16-1/4	60002J	100	600
1/8	Short	1 3/4	1/4	1/8-1/2	60004J	100	600
1/8	Long	2 1/4	1/4	5/8-7/8	60006J	100	600
1/8	Extra Long	2 11/16	1/4	1 1/4-1 1/2	60008J	100	600
3/16	Short	2	3/8	1/8-5/8	60011J	50	300
3/16	Long	2 1/2	3/8	5/8-1 1/16	60012J	50	300
3/16	Extra Long	3	3/8	1 1/4-1 3/4	60014J	50	300
1/4	Short	2 1/4	1/2	1/8-1/2	60016J	50	300
1/4	Long	2 3/4	1/2	5/8-7/8	60018J	50	300
1/4	Extra Long	3 3/8	1/2	1 1/4-1 3/4	60020J	50	300

HOLLOW WALL ANCHORS • PHILLIPS/SLOTTED SCREWS WITH DRIVE POINT



- Easy to install, requires no drilling.
 - Screw can be removed as often as needed.
- Installation**
1. Drive anchor with hammer until cap prongs are embedded in the wall.
 2. Turn screw clockwise to tighten.

					Gravity Feed Jar		
Thread Size	Length	Sleeve Length	Drill Size	Wall Thickness	Part #	Jar Qty	Master Carton
1/8	SD	1 3/8	1/4	1/8-1/2	60026J	100	600
1/8	LD	2	1/4	5/8-7/8	60028J	100	600
1/8	SLD	2 3/8	1/4	1/8-1 1/16	60030J	50	300

SnapSkru™ SP™ by TOGGLER® SELF-DRILLING DRYWALL ANCHORS

SnapSkru™ SP™ self-drilling drywall anchor locks on the wall.

- Self-drilling – no pre-drilled hole required.
- The anchors accept a wide range of screw sizes: #6, #8, and #10.
- Anchors “pop” open and lock positively on the rear of the wall to resist vibration and shock in walls and in ceilings.

- Installs with a screwdriver or screw gun.
- Unique tip prevents “walking” to ensure accurate and easy drilling.
- The unique, positive-stop built into the head of the anchor resists overturning and drive-through.
- Can remove screw and item, leaving anchor in wall for reuse.



RATED FOR OVERHEAD APPLICATIONS!

Installation

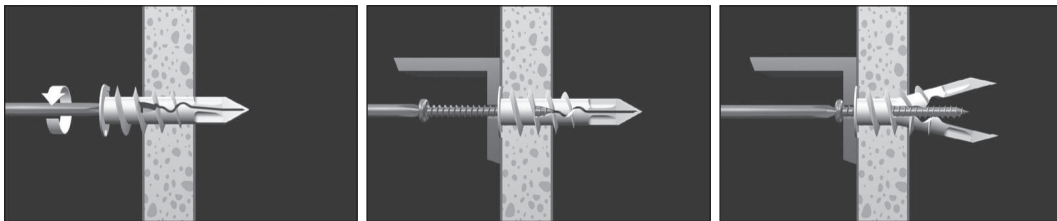

1. Drive anchor clockwise into drywall until anchor stops flush with the wall.
2. Place item over anchor and insert screw.
3. Tighten screw flush with item. Screw “pops” open anchor, locking anchor on wall.

Holding Power

- 1/2" Drywall holds 79 lbs
- 5/8" Drywall holds 135 lbs

	Gravity Feed Jar	Kits
Description	Part #	Part #
#8 SnapSkru™ Kit		
SnapSkru™ Anchors (40 Pieces)	39933J	39933
#8 x 1 1/2" Slot/Phil Screws (40 Pieces)	(80 Piece Kit)	(80 Piece Kit)

U.S. Patent Nos. 7,144,212 & 7,320,569 and foreign counterparts thereof. Other patents pending. TOGGLER and SnapSkru are worldwide registered trademarks of Mechanical Plastics Corp.

TOGGLER® PLASTIC TOGGLE ANCHORS

				Cardboard Box		
Wall Thickness	Drill Size	Screw Diameter	Type	Part #	Box Qty	Master Carton
1/8–1/4	5/16	#8	A	68006 ★	100	100
3/8–1/2	5/16	#8	B	68008 ★	100	100
5/8–3/4	5/16	#8	C	68010 ★	100	100

★ Made in USA



U.S. Patent Nos. 4,993,901 & 5,028,186 and foreign counterparts thereof and of 4,878,790. Other patents pending. TOGGLER is a worldwide registered trademark of Mechanical Plastics Corp.

TOGGLER® ALLIGATOR® SOLID & HOLLOW WALL ANCHORS • PLASTIC

- Highly versatile plastic anchor molds to wall for a tight fit.

Great for use in:			
• Cinder Block	• Concrete	• Masonry	• Stucco
• Drywall	• Brick	• Ceramic Tile	• Particle Board



			Gravity Feed Jar		
Description	Alligator #	Drill Size	Part #	Jar Qty	Master Carton
#8-10 with Flange	AF5	3/16"	59411J ★	100	1200
#10-12 with Flange	AF6	1/4"	59416J ★	100	600
#12-14 with Flange	AF8	5/16"	59417J ★	100	600
#8-10 without Flange	A6	1/4"	59418J ★	100	600

★ Made in USA

FASTENERS • ANCHORS

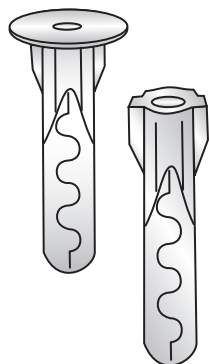

Application:

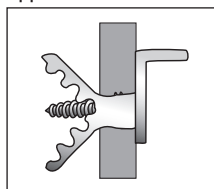

Kits	
Part #	Description
#8-10 Alligator w/Square Drive Screws Includes 3/16" Carbide Bit	
39412	#8-10 Alligators (AF5) (50 Pieces) (101 Pc Kit) #8 x 1 1/4" Sq Dr Screws (50 Pieces)
#8-10 Alligator w/Hex Washer Head Screws Includes 3/16" Carbide Bit	
39414	#8-10 Alligators (AF5) (50 Pieces) (101 Pc Kit) #8 x 1 1/4" HWH Screws (50 Pieces)
#8-10 Alligator w/Slot/Phil Combo Screws Includes 3/16" Carbide Bit	
39411	#8-10 Alligators (AF5) (50 Pieces) (101 Pc Kit) #8 x 1 1/4" Combo Dr Screws (50 Pieces)
#10-12 Alligator w/Square Drive Screws Includes 1/4" Carbide Bit	
39415	#10-12 Alligators (AF6) (50 Pieces) (101 Pc Kit) #10 x 1 1/4" Sq Dr Screws (50 Pieces)
#10-12 Alligator w/Hex Washer Head Screws Includes 1/4" Carbide Bit	
39417	#10-12 Alligators (AF6) (50 Pieces) (101 Pc Kit) #10 x 1 1/4" HWH Screws (50 Pieces)

Kits	
Part #	Description
#10-12 Alligator w/Slot/Phil Combo Screws Includes 1/4" Carbide Bit	
39422	#10-12 Alligators (AF6) (50 Pieces) (101 Pc Kit) #10 x 1 1/4" Combo Dr Screws (50 Pieces)
#12-14 Alligator w/Square Drive Screws Includes 5/16" Carbide Bit	
39418	#12-14 Alligators (AF8) (50 Pieces) (101 Pc Kit) #12 x 1 1/2" Sq Drive Screws (50 Pieces)
#12-14 Alligator w/Hex Washer Head Screws Includes 5/16" Carbide Bit	
39420	#12-14 Alligators (AF8) (50 Pieces) (101 Pc Kit) #12 x 1 1/2" HWH Screws (50 Pieces)
#12-14 Alligator w/Slot/Phil Combo Screws Includes 5/16" Carbide Bit	
39421	#12-14 Alligators (AF8) (50 Pieces) (101 Pc Kit) #12 x 1 1/2" Combo Dr Screws (50 Pieces)

U.S. Patent Nos. 5,161,296 & 5,938,385 and foreign counterparts thereof and of 4,752,170. Other patents pending. TOGGLER and SnapSkru™ are worldwide registered trademarks of Mechanical Plastics Corp.



WEDGE ANCHORS • HEAVY DUTY • CONCRETE & STONE • ZINC

		 Gravity Feed Jar			
Size	Min Embed	Part #	Made in U.S.A.	Jar Qty	Master Carton
1/4 x 1 3/4	1 1/8	62028J	—	100	600
1/4 x 2 1/4	1 1/8	62036J	62036US*	100	600
1/4 x 3 1/4	1 1/8	62052J	62052US*	100	600
3/8 x 2 1/4	1 1/2	62236J	62236US*	50	300
3/8 x 2 3/4	1 1/2	62244J	62244US*	50	300
3/8 x 3	1 1/2	62248J	62248US*	50	300
3/8 x 3 3/4	1 1/2	62260J	62260US*	50	300
3/8 x 5	1 1/2	62280J	62280US*	150	150
3/8 x 7	1 1/2	62298*	62298US*	50	50
1/2 x 2 3/4	2 1/4	62444J	62444US*	25	150
1/2 x 3 3/4	2 1/4	62460J	62460US*	25	150
1/2 x 4 1/4	2 1/4	62468J	62468US*	25	150
1/2 x 5 1/2	2 1/4	62488J	62488US*	25	150
1/2 x 7	2 1/4	62498*	62498US*	25	25
5/8 x 3 1/2	2 3/4	62656J	62656US*	10	60
5/8 x 4 1/4	2 3/4	62672J	62672US*	10	60
5/8 x 5	2 3/4	62680*	62680US*	10	100
5/8 x 6	2 3/4	62696*	62696US*	10	10
5/8 x 8	2 3/4	—	62698US*	10	10
5/8 x 8 1/2	2 3/4	62700*	62700US*	10	10
3/4 x 4 3/4	3 1/4	62876*	62876US*	10	100
3/4 x 5 1/2	3 1/4	62888*	62888US*	10	100
3/4 x 6 1/4	3 1/4	62897*	62897US*	10	100
3/4 x 7	3 1/4	62898*	62898US*	10	10
3/4 x 8 1/2	3 1/4	62900*	62900US*	10	10
3/4 x 10	3 1/4	62910*	62910US*	10	10

*These items are packaged in cardboard boxes.

See page 241 for Stainless Steel.

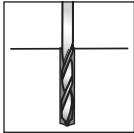
Installation

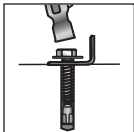
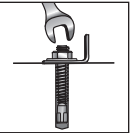
- 1) Select a carbide drill bit with a diameter equal to the anchor diameter. Drill hole to any depth exceeding the desired embedment.
 
- 2) Clean hole or continue drilling additional depth to accommodate drill fines.
 
- 3) Assemble washer and nut, leaving nut flush with end of anchor to protect threads. Drive anchor through material to be fastened until washer is flush to surface of material.
 
- 4) Expand anchor by tightening nut 3–5 turns past the hand tight position.
 



		 10 Packs	
Size	Min Embed	Part #	Box Qty
1/4 x 2 1/4	1/8	62037	10
1/4 x 3 1/4	1/8	62053	10
3/8 x 2 1/4	1 1/2	62237	10
3/8 x 2 3/4	1 1/2	62245	10
3/8 x 3	1 1/2	62249	10

For U.S. availability, please contact customer service.

Wedge Anchors are also called:

- Molly Bolts
- Red Heads
- Parabolts
- Kwikbolts
- Thunder Studs
- Stud Bolts

ACOUSTICAL WEDGE ANCHORS • OVERHEAD SUSPENSIONS



- Used to hang lighting fixtures and drop ceilings from concrete.
- Great for concrete and other solid materials.
- Sets when load is applied.



		Gravity Feed Jar		
Size	Bit Size	Part #	Jar Qty	Master Carton
¼ x 2¼	1⅝	62029J	100	600

See Tie Wire on page 96.

SLEEVE ANCHORS • MEDIUM DUTY • CINDER BLOCK & BRICK



- Can be used in brick, cinder block, thin wall, as well as solid concrete.
- Can be removed after installation (unlike wedge anchor).
- Use same drill size as bolt diameter.



		Gravity Feed Jar		
Size	Drill Style	Part #	Jar Qty	Master Carton
¼ x 1⅝	Acorn	61413J	100	600
¼ x 2¼	Acorn	61422J	100	600
⅜ x 1⅞	Hex	61617J	50	300
⅜ x 3	Hex	61630J	50	300
⅜ x 4	Hex	61640J	50	300
½ x 2¼	Hex	61822J	25	150
½ x 3	Hex	61830J	25	150
½ x 4	Hex	61840J	25	150

Installation

1. Use a solid carbide tipped bit. Drill the hole perpendicular to the work surface. Drill the hole as deep as the full length of the anchor.

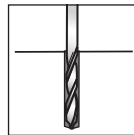

2. Clean the hole using compressed air and wire brush.



3. Insert anchor through the fixture and into the hole until nut and washer rest against the fixture, or tap into the hole and then place bracket over the anchor.

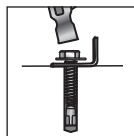

4. Tighten the nut with a torque wrench to the proper torque.

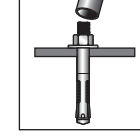

See page 239 for Stainless Steel.

STRIKE SET ANCHORS • SOLID CONCRETE

Installation

1. Drill hole to minimum depth and diameter. • Easier, faster installation.
2. Clean the hole with pressurized air.
3. Set nut and washer for proper installment.
4. Drive center pin flush with top of anchor.



Size	Gravity Feed Jar			10 Packs	
	Part #	Jar Qty	Master Carton	Part #	Box Qty
1/4 x 1 3/4	63028J	100	600	63029	10
1/4 x 2 3/8	63038J	100	600	63039	10
5/16 x 2	63132J	100	600	—	—
5/16 x 2 3/4	63144J	100	600	—	—
3/8 x 2 3/8	63238J	50	300	63239	10
3/8 x 3 1/2	63256J	50	300	63257	10
3/8 x 4 3/4	63276J	50	300	—	—
1/2 x 2 3/4	63444J	50	300	—	—
1/2 x 3 1/2	63456J	25	150	—	—
1/2 x 4 3/4	63476J	25	150	—	—

*These items are packaged in cardboard boxes.

ZAMAC “HAMMER DRIVE” NAIL-IN ANCHORS



- Economical choice for solid concrete, solid brick or block.
- Best suited for light-duty applications.
- Not recommended for vibrating loads or overhead installations.
- Requires no layout or hold spotting.
- 1,300 lb ultimate pullout (reference value). Use ¼ as safe working load (325#).

Installation

1. Drill hole ¼" deeper than required, blow hole clean of debris.
2. Insert anchor through fixture and hammer pin.



		Gravity Feed Jar			Job Jar	
Size	Drill Size	Part #	Jar Qty	Master Carton	Part #	Jar Qty
3/16 x 7/8	3/16	59011J	100	600	—	—
1/4 x 3/4	1/4	59012J	100	600	—	—
1/4 x 1	1/4	59016J	100	600	59016-6	200
1/4 x 1 1/4	1/4	59020J	100	600	59020-6	150
1/4 x 1 1/2	1/4	59024J	100	600	—	—
1/4 x 2	1/4	59032J	100	600	—	—

REMOVABLE ZAMAC “HAMMER DRIVE” NAIL-IN ANCHORS



	Gravity Feed Jar		
Size	Part #	Jar Qty	Master Carton
1/4 x 3/4	59012HSJ	100	600
1/4 x 1	59016HSJ	100	600
1/4 x 1 1/4	59020HSJ	100	600
1/4 x 1 1/2	59024HSJ	100	600
1/4 x 2	59032HSJ	100	600
1/4 x 2 1/4	59038HSJ	50	300
1/4 x 3	59048HSJ	50	300



NYLON NAIL-IN ANCHORS • LIGHT DUTY • REMOVABLE

Installation

1. Drill hole ¼" deeper than required, blow hole clean of debris.
2. Insert anchor through fixture and hammer pin.

- Removable version of Zamac Nail-In anchors.
- Often selected for bathroom applications (white finish).
- Light-duty applications only.
- 285 lb ultimate pull out (reference value). Use ¼ as safe work load (71#).

		Gravity Feed Jar		
Size	Drill Size	Part #	Jar Qty	Master Carton
¼ x 1	¼	61218J	100	600
¼ x 1½	¼	61226J	100	600
¼ x 2	¼	61232J	100	600



FASTENERS • ANCHORS

FLAT HEAD SPLIT BOLT ANCHORS • ZINC PLATED STEEL

- One piece “pre-expanded” anchor compresses as it is driven into base material.
- Very high shear values.
- Great for heavy-duty permanent installations.

		Gravity Feed Jar		
Size	Drill Size	Part #	Jar Qty	Master Carton
¼ x 1½	¼	59124J	100	600
¼ x 2½	¼	59140J	100	600
¼ x 3½	¼	59156J	100	600
¼ x 4	¼	59164J	50	300



EZ TOGGLE™ ANCORS

- One-piece hollow wall anchor offers superior pullout and shear values.
- No pre-drilling required.



 Gravity Feed Jar

Description	Part #	Jar Qty	Master Carton
EZ Toggle™ w/2" Phillips	59520J	100	600
EZ Toggle™ w/2" Square/Phillips	59521J	50	300

 Gravity Feed Jar

 Kits

Description	Part #	Part #
EZ Toggle™ w/2" Phillips		
EZ Toggles™ (25 Pieces)	39926J	39926
2" Screws (25 Pieces)	(50 Piece Kit)	(50 Piece Kit)
EZ Toggle™ w/2" Square/Phillips		
EZ Toggles™ (25 Pieces)	39927J	39927
2" Square/Phillips (25 Pieces)	(50 Piece Kit)	(50 Piece Kit)

LAG SCREW SHIELDS • MORTAR JOINT APPLICATIONS

- Screw style anchor designed for lag bolts.
- Best used on mortar joints of block or brick walls.
- Short style preferred for harder masonry.



				Gravity Feed Jar		
Lag Screw Diameter	Length	Drill Diameter		Part #	Jar Qty	Master Carton
¼ S	1	½		60602J	50	300
⅝ S	1¼	½		60606J	50	300
¾ S	1¾	⅝		60610J	50	300
½ S	2	¾		60614*	25	25
⅝ S	2	⅞		60618*	25	25
¼ L	1½	½		60604J	50	600
⅝ L	1¾	½		60618J	50	300
¾ L	2½	⅝		60612J	50	300
½ L	3			60616*	25	25

*These items are packaged in cardboard boxes.

Installation

1. Drill hole at least ½" deeper than minimum embedment.
2. Insert anchor into hole until it is flush with the surface.
3. Position fixture and insert lag bolt.
4. Tighten with wrench.

LEAD SCREW ANCHORS • ACCEPTS SHEET METAL OR WOOD SCREWS

- Designed for use with sheet metal screws or wood screws in concrete, block or brick.
- 100% lead alloy composition molds itself to form tight bond.
- Recommended for light-duty applications.
- See instructions above.



				Gravity Feed Jar		
Lag Screw Diameter	Length	Drill Diameter	Min Depth	Part #	Jar Qty	Master Carton
#6-8	¾	¼	¾	60802J	100	1200
#6-8	1	¼	1	60804J	100	1200
#6-8	1½	¼	1½	60806J	100	600
#10-12-14	¾	⅝	¾	60808J	100	600
#10-12-14	1	⅝	1	60810J	100	600
#10-12-14	1½	⅝	1½	60812J	100	600
#16-18	1	⅜	1	60814J	100	600
#16-18	1½	⅜	1½	60816J	100	600

STEEL DROP-IN ANCHORS



See page 240 for
Stainless Steel.

- Use with machine screw, bolt or threaded rod.
- For use in solid concrete, hard stone and solid block.
- Internally threaded expansion anchor.
- **Requires layout or hole spotting.**

					Gravity Feed Jar		
Thread Size	Length	Thread Depth	Drill/Hole Diameter	Min Embed	Part #	Jar Qty	Master Carton
1/4-20	1	7/8	3/8	1	60402J	100	600
3/8-16	1 1/16	5/8	1/2	1 5/8	60404J	100	600
1/2-13	2	1 3/16	5/8	2	60406J	50	300
5/8-11	2 1/2	1 3/16	7/8	2 1/2	60408J	25	150
3/4-10	3 3/8	1 3/16	1	3 3/16	60410J	25	150
3/8-16	Shallow Embedment Anchors		1/2	3/4	60405J	100	600



**Setting Tool
Included!**

Setting Tool		
Size	Part #	Qty
1/4	60440	1
3/8	60444	1
1/2	60446	1
5/8	60448	1
3/4	60450	1

Installation

1. Use a masonry bit. Drill the hole to any depth slightly deeper than the anchor length.
2. Clean the hole using pressurized air.
3. Insert the anchor into the hole and hammer the anchor down until it is flush with the surface.
4. Expand the anchor by hitting the setting tool until the shoulder is flush with the anchor.

LEAD MACHINE SCREW ANCHORS

			Gravity Feed Jar		
Thread Size	Drill/Hole Diameter	Min Embed	Part #	Jar Qty	Master Carton
10-24	3/8	5/8	60206J	100	600
1/4-20	1/2	7/8	60212J	100	600
5/16-18	5/8	1	60214J	100	600
3/8-16	3/4	1 1/4	60216J	50	300
1/2-13	7/8	1 1/2	60218J	50	300



Setting Tool		
Size	Part #	Qty
10-24	60236	1
1/4	60240	1
5/16	60242	1
3/8	60244	1
1/2	60248	1

- Great for installation in older concrete where crumbling is a concern.
- Lead alloy molds itself to concrete surface for a tight fit.
- Zamac 7 internally threaded core.
- **Requires layout or hole spotting.**



Installation

1. Drill a hole equal to the nominal diameter of the anchor and deeper than the intended embedment.
2. Clean the hole using compressed air.
3. Insert anchor into the hole and drive expander shield over cone using a setting tool.
4. Position fixture, insert fastener and tighten.

GREEN PLUG ANCHORS



		Gravity Feed Jar		
Description	Part #	Jar Qty	Master Carton	
#10-12 Green Plug Anchor	59425J	100	600	
#8-10-12 Green Plastic Anchor	59450J	100	600	



		Kits	
Part #	Description		
	#10-12 Green Plug Anchor with Hex Washer Head Screws		
39914 (201 Piece Kit)	#10 x 1" HWH Screws (100 Pieces)	#10-12 Green Plug Anchor (100 Pieces)	
	¼" Carbide Bit		

FASTENERS • ANCHORS

PAN HEAD Wall Dog™ ANCHORS



			Gravity Feed Jar		
Size	Drive	Description	Part #	Jar Qty	Master Carton
1¼	Phillips	Zinc	59504J	100	600
1¼	Phillips	White	59505J	100	600
1¼	Square	Zinc	59506J	100	600
1¼	Hex Washer Head Combo	Zinc	59507J	100	600

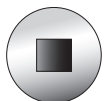

RED PLASTIC CONICAL ANCHORS

Installation

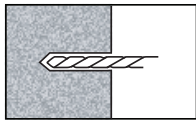

1. Drill proper size hole, 1/4" deeper than anchor length.

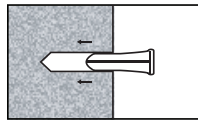

2. Insert anchor flush with surface of wall.

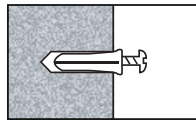

3. Insert wood or sheet metal screw through fixture and tighten.

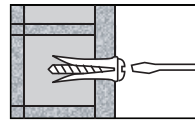

4. Anchor expands as wood or sheet metal screw is driven in.



Gravity Feed Jar				
Description	Drill Size	Part #	Jar Qty	Master Carton
#6-8 Red Conical	1/8"	59408J ★	100	600
#8-10 Red Conical	3/16"	59410J ★	100	600
#10-12 Red Conical	1/4"	59412J ★	100	600
#14-16 Red Conical	5/16"	59414J ★	100	600

All plastic anchor Jars include a masonry drill bit.

★ Made in USA

Description	Kits	Gravity Feed Jar
	Part #	Part #
#6 Slot/Phil Pan Head Red Conical Anchor Kit Includes 1/8" Carbide Bit		
#6 x 1" Screws (100 Pieces)	39816	39816J
#6-8 Anchors (100 Pieces)	(201 Piece Kit)	(201 Piece Kit)
#8 Square Drive Pan Head Red Conical Anchor Kit Includes 3/16" Carbide Bit		
#8 x 1" Screws (100 Pieces)	39708	—
#8-10 Anchors (100 Pieces)	(201 Piece Kit)	—
#8 Slot/Phil Pan Head Red Conical Anchor Kit Includes 3/16" Carbide Bit		
#8 x 1" Screws (100 Pieces)	39818	39819J
#8-10 Anchors (100 Pieces)	(201 Piece Kit)	(201 Piece Kit)
#8 Hex Washer Head Red Conical Anchor Kit Includes 3/16" Carbide Bit		
#8 x 1" Screws (100 Pieces)	39908	—
#8-10 Anchors (100 Pieces)	(201 Piece Kit)	—

Continued on next page.

RED PLASTIC CONICAL ANCHORS (CONT.)



FASTENERS • ANCHORS

	Kits	Gravity Feed Jar	Job Jar
Description	Part #	Part #	Part #
#10 Square Drive Pan Head Red Conical Anchor Kit Includes 1/4" Carbide Bit			
#10 x 1" Screws (100 Pieces)	39710	39711	39710-6
#10-12 Anchors (100 Pieces)	(201 Piece Kit)	(201 Piece Kit)	(401 Piece Kit)
#10 Slot/Phil Pan Head Red Conical Anchor Kit Includes 1/4" Carbide Bit			
#10 x 1" Screws (100 Pieces)	39820	39821	39820-6
#10-12 Anchors (100 Pieces)	(201 Piece Kit)	(201 Piece Kit)	(401 Piece Kit)
#10 Hex Washer Head Red Conical Anchor Kit Includes 1/4" Carbide Bit			
#10 x 1" Screws (100 Pieces)	39910	39911	39910-6
#10-12 Anchors (100 Pieces)	(201 Piece Kit)	(201 Piece Kit)	(401 Piece Kit)
#12 Slot/Phil Pan Head Red Conical Anchor Kit Includes 1/4" Carbide Bit			
#12 x 1" Screws (100 Pieces)	39822	39822J	—
#10-12 Anchors (100 Pieces)	(201 Piece Kit)	(201 Piece Kit)	—
#12 Hex Washer Head Red Conical Anchor Kit Includes 1/4" Carbide Bit			
#12 x 1" Screws (100 Pieces)	39912	—	—
#10-12 Anchors (100 Pieces)	(201 Piece Kit)	—	—
#12 Square Drive Pan Head Red Conical Anchor Kit Includes 1/4" Carbide Bit			
#12 x 1" Screws (100 Pieces)	39712	—	—
#10-12 Anchors (100 Pieces)	(201 Piece Kit)	—	—

YELLOW WINGED ANCHORS • PLASTIC

		Gravity Feed Jar		
Description	Drill Size	Part #	Jar Qty	Master Carton
#4-6-8 Yellow Vinyl	3/16	59431J ★	100	1200
#8-10-12 Yellow Vinyl	1/4	59432J	100	600
#12-14-16 Yellow Vinyl	5/16	59433J	100	600

★ Made in USA



	Kits	Gravity Feed Jar	Job Jar
Description	Part #	Part #	Part #
#8 Square Drive Pan Head Yellow Winged Anchor Kit – Includes 3/16" Carbide Bit			
#8 x 1" Screws (100 Pieces)	39717	39718	—
#4-6-8 Anchors (100 Pieces)	(201 Piece Kit)	(201 Piece Kit)	—
#8 Hex Washer Head Yellow Winged Anchor Kit – Includes 3/16" Carbide Bit			
#8 x 1" Screws (100 Pieces)	39747	39748	—
#4-6-8 Anchors (100 Pieces)	(201 Piece Kit)	(201 Piece Kit)	—
#8 Slot/Phil Pan Head Yellow Winged Anchor Kit – Includes 3/16" Carbide Bit			
#8 x 1" Screws (100 Pieces)	39756	39759	—
#4-6-8 Anchors (100 Pieces)	(201 Piece Kit)	(201 Piece Kit)	—
#10 Square Drive Pan Head Yellow Winged Anchor Kit – Includes 1/4" Carbide Bit			
#10 x 1" Screws (100 Pieces)	39721	39723	39723-6
#8-10-12 Anchors (100 Pieces)	(201 Piece Kit)	(201 Piece Kit)	(201 Piece Kit)
#10 Hex Washer Head Yellow Winged Anchor Kit – Includes 1/4" Carbide Bit			
#10 x 1" Screws (100 Pieces)	39751	39753	39753-6
#8-10-12 Anchors (100 Pieces)	(201 Piece Kit)	(201 Piece Kit)	(401 Piece Kit)
#10 Slot/Phil Pan Head Yellow Winged Anchor Kit – Includes 1/4" Carbide Bit			
#10 x 1" Screws (100 Pieces)	39761	39763	39763-6
#8-10-12 Anchors (100 Pieces)	(201 Piece Kit)	(201 Piece Kit)	(401 Piece Kit)
#12 Square Drive Pan Head Yellow Winged Anchor Kit – Includes 5/16" Carbide Bit			
#12 x 1 1/2" Screws (50 Pieces)	39722	39724	—
#12-14-16 Anchors (50 Pieces)	(101 Piece Kit)	(101 Piece Kit)	—
#12 Hex Washer Head Yellow Winged Anchor Kit – Includes 5/16" Carbide Bit			
#12 x 1 1/2" Screws (50 Pieces)	39752	39754	—
#12-14-16 Anchors (50 Pieces)	(101 Piece Kit)	(101 Piece Kit)	—
#12 Slot/Phil Pan Head Yellow Winged Anchor Kit – Includes 5/16" Carbide Bit			
#12 x 1 1/2" Screws (50 Pieces)	39762	39764	—
#12-14-16 Anchors (50 Pieces)	(101 Piece Kit)	(101 Piece Kit)	—

EXPANDER ANCHORS • PLASTIC



	Gravity Feed Jar		
Description	Part #	Jar Qty	Master Carton
#8-10 Expander Anchors	59440J ★	100	600

★ Made in USA

	Gravity Feed Jar
Description	Part #
#8 Square Drive Pan Head Expander Anchor Kit Includes ¼" Carbide Bit	
#8 Expander Anchor (100 Pieces) 8 x 1½" Screws (100 Pieces)	39727 (201 Piece Kit)
#10 Square Drive Pan Head Expander Anchor Kit Includes ¼" Carbide Bit	
#10 Expander Anchor (100 Pieces) 10 x 1½" Screws (100 Pieces)	39728 (201 Piece Kit)
#8 Hex Washer Head Expander Anchor Kit Includes ¼" Carbide Bit	
#8 Expander Anchor (100 Pieces) 8 x 1½" Screws (100 Pieces)	39757 (201 Piece Kit)
#10 Hex Washer Head Expander Anchor Kit Includes ¼" Carbide Bit	
#10 Expander Anchor (100 Pieces) 10 x 1½" Screws (100 Pieces)	39758 (201 Piece Kit)
#8 Phillips/Slotted Pan Head Expander Anchor Kit Includes ¼" Carbide Bit	
#8 Expander Anchor (100 Pieces) 8 x 1½" Screws (100 Pieces)	39767 (201 Piece Kit)
#10 Phillips/Slotted Pan Head Expander Anchor Kit Includes ¼" Carbide Bit	
#10 Expander Anchor (100 Pieces) 10 x 1½" Screws (100 Pieces)	39768 (201 Piece Kit)

FASTENERS • ANCHORS

SAMMYS® FOR WOOD • VERTICAL MOUNTING

					Gravity Feed Jar		
Size	Model	Approvals	Rod Size	Nut Driver	Part #	Jar Qty	Master Carton
¼ x 1	GST 100	—	¼	61192	61144J ★	25	150
¼ x 2	GST 200	—	¼	61192	61145J ★	25	150
¼ x 1	GST 10	UL	⅜	61192	61147J ★	25	150
¼ x 2	GST 20	UL • FM	⅜	61192	61148J ★	25	150
¼ x 3	GST 30	UL • FM	⅜	61192	61150J ★	25	150
¼ x 2	GST 2	—	½	61193	61152J ★	25	150
⅜ x 2½	GST25-380	UL • FM	⅜	61192	61182J ★	25	150

★ Made in USA

Application

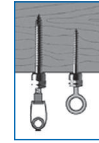

Nut Drivers

#61192 (Black) #61193 (Red)

FASTENERS • HANGERS

SAMMYS® FOR WOOD • HORIZONTAL MOUNTING

					Gravity Feed Jar		
Size	Model	Approvals	Rod Size	Nut Driver	Part #	Jar Qty	Master Carton
¼ x 1	SWG 10	UL	⅜	61193	61156J ★	25	150
¼ x 2	SWG 20	UL	⅜	61193	61157J ★	25	150
⅜ x 2½	SWG 25-380	UL	⅜	61193	61183J ★	25	150

★ Made in USA

Application

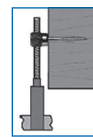

SAMMYS® FOR STEEL • VERTICAL MOUNTING

Application



						Gravity Feed Jar		
Size	Model	Approvals	Rod Size	Nut Driver	Part #	Jar Qty	Master Carton	
¼-20 x 1	DSTR 100	—	¼	61192	61160J ★	25	150	
¼-14 x 2	DST 200	—	¼	61192	61162J ★	25	150	
⅝-18 X 1¼	DSTR 516	UL • FM	⅜	61192	61166J ★	25	150	
12-24 x 1½	DSTR 1½	UL • FM	⅜	61192	61168J ★	25	150	
¼-20 x 1	DSTR 1	UL • FM	⅜	61192	61169J ★	25	150	
¼-14 x 1	DST 10	—	⅜	61192	61170J ★	25	150	
¼-14 x 2	DST 20	—	⅜	61192	61172J ★	25	150	
12-24 x 1½	TEK 50	UL • FM	⅜	61192	61174J ★	25	150	
¼-14 x 2	DST 2.0	—	½	61193	61164J ★	25	150	
12-24 x 1½	TEK 5.0	—	½	61193	61167J ★	25	150	

★ Made in USA

Nut Drivers



#61192 (Black) #61193 (Red)

SAMMYS® FOR STEEL • HORIZONTAL MOUNTING

Application

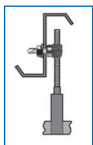

						Gravity Feed Jar		
Size	Model	Approvals	Rod Size	Nut Driver	Part #	Jar Qty	Master Carton	
¼-20 x 1	SWDR 100	—	¼	61193	61176J ★	25	150	
¼-14 x 1	SWD 10	—	⅜	61193	61177J ★	25	150	
¼-14 x 2	SWD 20	—	⅜	61193	61179J ★	25	150	
⅝-18 X 1¼	SWDR 516	—	⅜	61193	61180J ★	25	150	
¼-20 x 1½	SWDR 1½	UL • FM	⅜	61193	61181J ★	25	150	

★ Made in USA

SAMMYS® FOR CONCRETE • VERTICAL MOUNTING

					Gravity Feed Jar		
Size	Model	Approvals	Rod Size	Nut Driver	Part #	Jar Qty	Master Carton
5/16 x 1 3/4	CST 200	—	1/4	61192	61185J ★	25	150
5/16 x 1 3/4	CST 20	FM	3/8	61192	61186J ★	25	150
5/16 x 1 3/4	CST 2	—	1/2	61193	61187J ★	25	150

Application



★ Made in USA



SAMMYS® FOR CONCRETE • HORIZONTAL MOUNTING

					Gravity Feed Jar		
Size	Model	Approvals	Rod Size	Nut Driver	Part #	Jar Qty	Master Carton
5/16 x 1 3/4	SWC 20	—	3/8	61193	61188J ★	25	150

★ Made in USA



Application

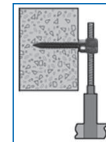



Kits			
Part #	Description		
61190 ★ (7 Piece Kit)	Concrete Installation Kit		
	#250 – Bit (1/4")	SDS 250 Bit (1/4")	7/32" Wood Bit
	Hex 250 – Bit Receiver (1/4")	#14 Nut Driver	#14 SW Nut Driver
	SL 250 – Sleeve		

★ Made in USA



Nut Drivers

 #61192
(Black)



 #61193
(Red)

FASTENERS • HANGERS

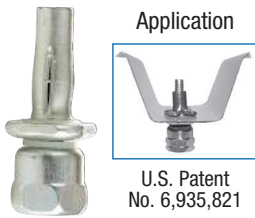
SAMMYS® X-PRESS • USE WITH ¼" OR ⅜" ROD

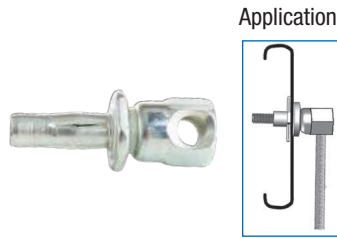

Sammys X-Press
(for vertical attachment)



Sammys X-Press Sidewinder
(for horizontal attachment)
#61202



- Pipe Hanger for X-Treme Roof Pitches.
 - 89° in purlin
 - 45° in metal deck for 12/12 pitch
- Installs in seconds, saves time and installation costs.
- Use in applications where easy access to the back of the installed faster is prohibited.
- No retaining nut required.

							Gravity Feed Jar		
Description	Model	Rod Size	Max Pipe Size	Steel Gauge	Approvals	Application	Part #	Jar Qty	Master Carton
Sammys X-Press 20	XP 20	⅜-16	4	12	FM	Metal Deck	61194J ★	25	150
Sammys X-Press 35	XP 35	⅜-16	4	12	FM	Purlin	61197J ★	25	150
Sidewinder X-Press 35	SWXP 35	⅜-16	3½	16-12	UL	Purlin	61202J ★	25	150
Swivel X-Press 20	SXP 20	⅜-16	2	22-20	UL	Metal Deck	61203J ★	25	150
Swivel X-Press 35	SXP 35	⅜-16	3½	16-12	UL	Purlin	61204J ★	25	150
Sammys X-Press 200	XP 200	¼-20	185 lbs*	—	UL	Metal Deck	61198J ★	25	150

★ Made in USA



Universal X-Press It® Installation Tool
#61200

		Cardboard Box	
Description	Model	Part #	Qty
Retro Socket	RXPIT	61195 ★	1
Universal X-Press It Tool	UXPIT	61200 ★	1
Replacement Bit for 61200		61201 ★	1

★ Made in USA

ROD HANGERS • METAL APPLICATIONS • VERTICAL MOUNTING

		Gravity Feed Jar		
Threaded Size	OAL	Part #	Jar Qty	Master Carton
1/4-20	2 1/2	59670J	50	300
3/8-16	1 7/8	59671J	50	300

- Tapped to accept 1/4-20 and 3/8-16 threaded rod.
- Installs easily with insert socket.



See installation tool **(59679)** on page 94.

Starter Kit			
Part #	Description		
59643			
(21 Piece Kit)	1/4" Self-Drilling Anchors (10 Pieces)	3/8" Self-Drilling Anchors (10 Pieces)	3/8" Recessed Drive Socket (1 Piece)

ROD HANGERS • WOOD APPLICATIONS • VERTICAL MOUNTING

		Gravity Feed Jar		
Threaded Size	OAL	Part #	Jar Qty	Master Carton
1/4-20	2 1/2	59672J	50	300
3/8-16	1 7/8	59673J	50	300

- Tapped to accept 1/4-20 and 3/8-16 threaded rod.
- Yellow dichromate finish for outstanding corrosion protection.
- Installs easily with insert socket.



See installation tool **(59679)** on page 94.

Starter Kit			
Part #	Description		
59645			
(21 Piece Kit)	1/4" Wood-Drilling Anchors (10 Pieces)	3/8" Wood-Drilling Anchors (10 Pieces)	3/8" Recessed Drive Socket (1 Piece)

ROD HANGERS • CONCRETE APPLICATIONS • VERTICAL MOUNTING

		Gravity Feed Jar		
Threaded Size	OAL	Part #	Jar Qty	Master Carton
1/4-20		59677J	50	300
3/8-16		59678J	50	300

- Tapped to accept 1/4-20 and 3/8-16 threaded rod.
- Yellow dichromate finish for outstanding corrosion protection.
- Installs easily with insert socket.



See installation tools **(59680, 59681)** on page 94.

ROD HANGERS • METAL APPLICATIONS • HORIZONTAL MOUNTING



- Tapped to accept 3/8"-16 threaded rod.
- New sidemount configuration offers added convenience.

Requirements:

- Driver required. Order part #59679.

			Gravity Feed Jar		
Description	Application	OAL	Part #	Jar Qty	Master Carton
3/8"-16	Steel	2 3/4"	59674J	50	300
3/8"-16	Wood	2 3/4"	59675J	50	300

See installation tool (59679) below.

ROD HANGER DRIVER INSTALLATION TOOL



Description	Application	Part #	Qty
Rod Hanger Driver	Wood/Steel	59679	1
Rod Hanger Driver 1/4"	Concrete	59680	1
Rod Hanger Driver 3/8"	Concrete	59681	1

THREADED ROD



- When shipping an order including 10' lengths and over, contact customer service for minimum freight pre-pay.
- Rod is sold per piece, not per foot.

Zinc			
Size	Part #	Tube Wt. (lbs)	Tube Qty
1/4"-20 x 3'	59703	18	50
3/8"-16 x 3'	59702	21	25
1/4"-20 x 6'	59704	36	50
5/16"-18 x 6'	59705	40	35
3/8"-16 x 6'	59706	43	25
1/2"-13 x 6'	59708	37	12
5/8"-11 x 6'	59710	25	5
1/4"-20 x 10'	59804	60	50
5/16"-18 x 10'	59805	67	35
3/8"-16 x 10'	59806	72	25
1/2"-13 x 10'	59808	61	12
5/8"-11 x 10'	59810	41	5

Dimension All Thread Rod (ATR)

- Dimensions taken from ANSI B1.1-1982 Unified Inch Screw Threads.
- All threads are UNCR series.
- Tabulated loads are based on an allowable tensile stress of 12000 psi (82.7 MPa) reduced by 25% resulting in 9000 psi (62 MPa). From ANSI/MSS SP-58, Table 3.

Nominal Size & Thread	Root Area		Design Load (SF=5)	
	in. ²	cm ²	lbs	kN
1/4" - 20	0.027	0.174	240	1.07
5/16" - 18	0.045	0.290	400	1.78
3/8" - 16	0.068	0.438	610	2.71

See page 256 for Stainless Steel.

See page 96 for Hex Rod Couplings.

HANGERBOLTS • ZINC

- Bolt with threaded areas at both ends, lag screw thread at one end and unified thread at the other.
- Standard hanger bolts insert into a predrilled pilot hole.
- The end of the wood thread tapers is threaded all the way to its blunt tip.



Gravity Feed Jar			
Size	Part #	Jar Qty	Master Carton
1/4 x 1 1/2	66124J	100	600
1/4 x 2	66132J	100	600
1/4 x 2 1/2	66140J	100	600
1/4 x 3	66148J	100	600
1/4 x 4	66164J	50	300
3/8 x 2 1/2	66340J	100	600
3/8 x 3	66348J	50	300
3/8 x 3 1/2	66356J	50	300
3/8 x 4	66364J	25	150

FASTENERS • HANGERS

HANGERBOLT DRIVERS

- Driver has internal threads with an easy release ball bearing at the bottom to relax easily, saving time.

Plastic Bag		
Size	Part #	Qty
1/4-20 x 2 9/16	39101	1
3/8-16 x 2 9/16	39103	1



HEX ROD & REDUCING COUPLINGS • ZINC



See page 256 for
Stainless Steel.

		Gravity Feed Jar		
Size	Couplings	Part #	Jar Qty	Master Carton
1/4-20 x 7/8	Hex Rod	59604J	100	600
5/16-18 x 7/8	Hex Rod	59605J	100	600
3/8-16 x 1-1/8	Hex Rod	59606J	100	600
1/2-13 x 1 3/4	Hex Rod	59608J	50	300
1/4-20 to 3/8-16	Reducing	59625J	50	300
3/8-16 to 1/2-13	Reducing	59626J	50	300

FASTENERS • HANGERS

TIE WIRE



- When shipping an order including 10' lengths and over, contact customer service for minimum freight pre-pay.

				Cardboard Box	
Description	Gauge	Length	Weight (lbs)	Part #	Box Qty
Tie Wire (Steel Black Annealed Coil)	#16	340'	3 1/2	71000	20 Coils
Tie Wire (Galvanized Coil)	#16-1/2	450'	4	71001	20 Coils
Ceiling Tie Wire (Galvanized Length)	#12	10'	—	69950 ★	100 Pcs/ Bundle
Ceiling Tie Wire (Galvanized Length)	#12	8'	—	69951 ★	100 Pcs/ Bundle
Tie Wire (Galvanized Length)	#12	6'	—	69952 ★	100 Pcs/ Bundle
Tie Wire (Galvanized with Anchor Clip)	#12	10'	—	69955 ★	100 Pcs/ Bundle
Tie Wire (Galvanized with Anchor Clip)	#12	8'	—	69956 ★	100 Pcs/ Bundle
Tie Wire (Galvanized with Anchor Clip)	#12	6'	—	69957 ★	100 Pcs/ Bundle

★ Made in USA



JACK CHAIN • ZINC PLATED

- For support of light fixtures and signs.
- Zinc plated steel.

		Cardboard Box		Reel		Bucket	
Work Load Limit (lbs)	Gauge	Part #	Box Qty	Part #	Reel Qty	Part #	Bucket Qty
48	#10	72011 ★	100'	72010 ★	100'	72018 ★	300'
29	#12	72013 ★	100'	72012 ★	100'	72020 ★	300'
16	#14	72015 ★	100'	72014 ★	200'	—	—
11	#16	—	—	72016 ★	250'	—	—

★ Made in USA



See page 257 for Stainless Steel.

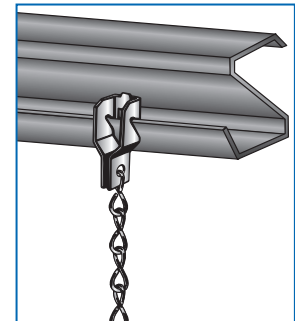

FASTENERS • HANGERS

DOUBLE LOOP TENSO CHAIN • ZINC PLATED

			Reel	
Work Load Limit (lbs)	Gauge	Size	Part #	Box Qty
255	#10	2/0	74002 ★	175'
200	#10	1/0	74010 ★	100'
155	#12	1	74011 ★	200'
90	#14	3	74013 ★	200'
90	#14	3	74014 ★	100'

Sold by box/pkg (not by foot)

★ Made in USA

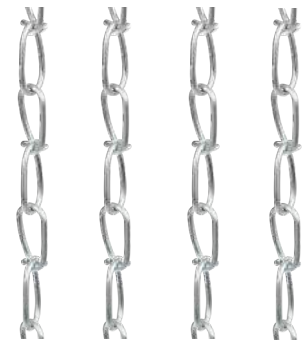

PLUMBER'S TAPE (PERFORATED STRAP IRON) • GALVANIZED & COPPER



Gauge	Type	Width	Length	Part #	Unit	Std Pack
22	Galvanized	¾"	10'	94422 ★	1	100 Rolls
24	Copper	¾"	10'	94430 ★	1	100 Rolls
28	Galvanized	¾"	10'	94428 ★	1	100 Rolls
26	Galvanized	¾"	10'	94426 ★	1	100 Rolls

★ Made in USA

FASTENERS • HANGERS

S-HOOKS • ZINC



- For hanging Jack Chain to various overhead hangers.
- Made from pre-galvanized steel.

See page 257 for
Stainless Steel.

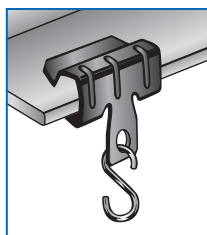

	Gravity Feed Jar		
Size	Part #	Jar Qty	Master Carton
¾"	70012J ★	100	600
1"	70016J ★	100	600
1¼"	70020J ★	100	600
1½"	70024J ★	100	600
2"	70032J ★	100	600
2½"	70040J ★	100	600
3"	70048J ★	50	300

★ Made in USA

V-HOOKS • FLUORESCENT FIXTURE HANGERS • ZINC

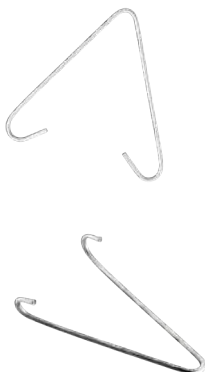

- For use with fluorescent lighting fixtures holding 2, 3, or 4 bulbs.

Side Mount		
Size	Part #	Qty
10 Gauge	70000 ★	50

★ Made in USA

Top/End Mount		
Size	Part #	Qty
10 Gauge	70002 ★	50

★ Made in USA

KRYLON® INDUSTRIAL QUIK-MARK™ INVERTED MARKING PAINT

- Make a mark fast in all types of wind and weather.
- A heavy-duty industrial paint.
- Fast drying, high solids formula that penetrates and adheres to hot and cold surfaces.
- Features exclusive Spray-Thru™ cap and non-clogging spray tip.
- Available in APWA colors (American Public Works Association) and fluorescent colors.
- VOC-compliant and lead free.
- Solvent-Based paints are the best choice for cool or damp conditions.
- Water-Based paints are best suited for hot and dry conditions.
- See the Color Selection Guide on page 112.

Uses:

- Ground Surveying
- Construction Marking
- Excavation
- Utility



**Know what's below.
Call before you dig.**



Description	Base Type	SDS REF #	Part #	Can Size	Net Fill	Std Pk
Fluorescent Safety Red	Water-Based	A03610004	37681 ★	20 oz	17 oz	12
Fluorescent Safety Green	Water-Based	A03630004	37459 ★	20 oz	17 oz	12
Fluorescent Orange	Water-Based	A03700004	37460 ★	20 oz	17 oz	12
Fluorescent Pink	Water-Based	A03612004	37655 ★	20 oz	17 oz	12
Brilliant Red	Water-Based	A03911004	37676 ★	20 oz	17 oz	12
Brilliant White APWA	Water-Based	A03901004	37461 ★	20 oz	17 oz	12
Utility Yellow APWA	Water-Based	A03801004	37462 ★	20 oz	17 oz	12
Orange APWA	Water-Based	A03905004	37692 ★	20 oz	17 oz	12
Fluorescent Red/Orange	Water-Based	A03650004	37463 ★	20 oz	17 oz	12
Fluorescent Caution Blue	Water-Based	A03620004	37465 ★	20 oz	17 oz	12
Clear	Water-Based	A03500004	37466 ★	20 oz	17 oz	12
Purple	Water-Based	A03715004	37659 ★	20 oz	17 oz	12
Red APWA	Solvent-Based	A03611007	37455 ★	20 oz	17 oz	12
Hi-Vis Yellow APWA	Solvent-Based	A03821007	37467 ★	20 oz	17 oz	12
Fluorescent Orange	Solvent-Based	A03702007	37468 ★	20 oz	17 oz	12
Utility White APWA	Solvent-Based	K00559007	37469 ★	20 oz	17 oz	12
Fluorescent Red/Orange	Solvent-Based	AT3701007	37470 ★	20 oz	17 oz	12
Blue APWA	Solvent-Based	A03621007	37471 ★	20 oz	17 oz	12
Green APWA	Solvent-Based	A03601007	37472 ★	20 oz	17 oz	12
Orange APWA	Solvent-Based	A3501007	37669 ★	20 oz	17 oz	12
Bright Orange APWA	Solvent-Based	A03731007	37693 ★	20 oz	17 oz	12
Fluorescent Hot Pink	Solvent-Based	A03622007	37482 ★	20 oz	17 oz	12
Clear	Solvent-Based	A03600007	37647 ★	20 oz	17 oz	12

★ Made in USA

You can find access to all current SDS sheets on the Krylon Products Group website.

www.KPG-Industrial.com

COLOR SELECTION GUIDE • INVERTED MARKING PAINT

Application	Color	Water-Based Cully Part #	Solvent-Based Cully Part #
Electric Power Lines, Cables, Conduit and Lighting Cables	Fluorescent Red/Orange	37463 ★	37470 ★
	Red APWA	—	37455 ★
	Fluorescent Red	37681 ★	—
Gas, Oil, Steam, Petroleum or Gaseous Materials	Utility Yellow APWA	37462 ★	—
Communication, Alarm or Signal Lines, Cables or Conduit	Fluorescent Orange	37460 ★	37468 ★
Potable Water	Fluorescent Caution Blue	37465 ★	—
	Blue APWA	—	37471 ★
Sewers and Drain Lines	Fluorescent Safety Green	37459 ★	—
	Green APWA	—	37472 ★
Temporary Survey Markings	Fluorescent Hot Pink	37655 ★	37482 ★
Proposed Excavation	Brilliant White APWA	37461 ★	—
	Utility White APWA	—	37469 ★
General Purpose and Chalk Line Extender	Clear	37466 ★	37647 ★
Roads, Highway Pavement	Hi-Visibility Yellow APWA	—	37467 ★

★ Made in USA

PAINT ACCESSORIES

Description	Compatibility	SDS Ref #	Part #	Unit
Wheeler Hand-Held Wand (34" Length)	Inverted Marking Paint (20 oz or 16 oz Cans)	K07096	37456 ★	1
Can Holster	Inverted Marking Paint (20 oz or 16 oz Cans)	K08000000	37457 ★	1
Snap & Spray™ Can Adapter	Aerosol Paint Cans	K07099	37458 ★	12

★ Made in USA

Marking Wand

37456 ★

- Constructed of durable, rugged plastic and lightweight steel.
- Comfortable pistol grip for easy handling and marking.
- Apply a uniform 1" to 1½" width of paint.
- Can Holster also available.



Can Holster

37457 ★

- Specially designed for holding inverted marking paint cans.
- Features rugged holster.
- Measures: 3½" diameter x 6½" high.



★ Made in USA

Can Adapter

37458 ★

- Transforms any standard spray can of paint, cleaner or lubricant into a spray gun.
- Snaps easily onto can rim.
- Eliminates finger fatigue.
- Trigger lock prevents accidental use.



KRYLON® INDUSTRIAL TOUGH COAT® ACRYLIC ENAMEL PAINT

Description	SDS Ref #	Part #	Can Size	Net Fill	Std Pk
OSHA Safety Green	A01470007	37473 ★	16 oz	12 oz	12
OSHA Black	A01770007	37474 ★	16 oz	12 oz	12
OSHA White	A01800007	37475 ★	16 oz	12 oz	12
OSHA Yellow	A01310007	37476 ★	16 oz	12 oz	12
Semi-Flat Black	A03725007	37477 ★	16 oz	12 oz	12
Max Flat Black	A03727007	37478 ★	16 oz	12 oz	12
OSHA Red	A01110007	37479 ★	16 oz	12 oz	12
OSHA Blue	A01510007	37480 ★	16 oz	12 oz	12
OSHA Orange	A01210007	37481 ★	16 oz	12 oz	12
Machinery Dark Gray (ASA-49)	A00325007	37485 ★	16 oz	12 oz	12
Medium Gray	A01615007	37486 ★	16 oz	12 oz	12
Industrial Gray	A01630007	37487 ★	16 oz	12 oz	12
Light Gray	A01645007	37488 ★	16 oz	12 oz	12
Blue/Gray	A01625007	37489 ★	16 oz	12 oz	12
Machinery Gray	A01620007	37490 ★	16 oz	12 oz	12
Machine Blue/Gray (ASA-24)	A00329007	37491 ★	16 oz	12 oz	12
Machinery Light Gray (ASA-61)	A00326007	37492 ★	16 oz	12 oz	12

★ Made in USA

- Features patented EZ Touch™ fan spray nozzle that requires 50% less finger pressure than most other paint valves.
- Ideal for light to heavy duty painting projects, both indoors and outdoors.
- Tough, protective coating resists chipping and peeling.
- Excellent hiding characteristics.
- Low odor and VOC-compliant
- Dries to the touch in 15 minutes.

Uses:

- Metal
- Motors
- Tools
- Machinery
- Railings & Electrical Equipment



You can find access to all current SDS sheets on the Krylon Products Group website.

www.KPG-Industrial.com

CONTACT CLEANER SELECTION GUIDE

Chemical Properties

Product Description/ Part #	O.K. for These Substrates						Removes These Contaminants					Chemical Properties			
	Metals	Polycarb.	ABS	Nylon	Teflon	PVC	Light Oil	Flux	Solder	Rosin	Dust	Flash Point	Drying Time	Dielectric Strength	Plastic Safe
Electro Wizard 37680	X	X	X	X	X	X	B	A	A	A	B	None	Very Fast	12,500	Yes
Plastics Contact Cleaner 37504	X	X	X	X	X	X	B	C	—	C	B	None	Very Fast	19,000	Yes
Electronic Contact Cleaner 37506	X	X	X	X	X	X	A	A	A	A	A	None	Fast	N/A	Yes

A = Strong Cleaning Action

B = Good Cleaning Action

C = Moderate Cleaning Action

Is maximum solvency your main concern?

Yes, and I need a high Dielectric Strength as well.

**Plastics
Contact Cleaner**

37504

Yes, and I accept a lower Dielectric Strength if it costs less.

**3-2-1
Contact Cleaner**

37680

Do you require a non-chlorinated product?

Yes, and I'm not concerned with flammability.

**Environmental
Cleaner/Degreaser**

37501

Are you seeking an economical cleaner?

Yes, and I want a non-chlorinated product.

**Environmental
Contact Cleaner**

37506

Are you looking for the best Plastics Contact Cleaner?

Yes, and I'm not concerned about the price.

**Plastics
Contact Cleaner**

37504

Is High Dielectric Strength your main concern?

Yes, and I want no flash point.

**Plastics
Contact Cleaner**

37504

CONTACT CLEANER SELECTION GUIDE

Chemical Properties																
Product Description/ Part #	O.K. for These Substrates						Removes These Contaminants						Chemical Properties			
	Fiberglass	Plastic	Rubber	Teflon	Metal	Nylon	Tar/Asphalt	Grease	Ink	Wax	Adhesives	Carbon Dust	Flash Point	Drying Time	Dielectric Strength	Plastic Safe
Flash Free Safety Solvent 37497/37498	—	X	X	X	X	—	A	A	A	B	A	B	None	Fast	37,000	Yes
Electrical Cleaner & Lubricating Spray 37499	—	X	X	X	X	—	A	A	B	B	B	B	None	Fast	36,700	Yes
Environmental Cleaner/Degreaser 37501	—	X	X	X	X	X	B	A	A	B	A	B	-20	Very Fast	N/A	No
Electric Motor Degreaser/Safety Solvent 37502	—	—	X	X	X	—	A	A	A	B	A	A	None	Fast	39,500	No

A = Strong Cleaning Action B = Good Cleaning Action C = Moderate Cleaning Action

Is maximum solvency your main concern?	Yes, and I don't want to leave a residue film.	F.F. Safety Solvent/Degreaser 37498
	Yes, and I want a lubricating film.	Electrical Cleaner and Lube Spray 37499
Do you require a non-chlorinated product?	Yes, even if it has lower solvency and a lower flash point.	Environmental Cleaner/Degreaser 37501
Is very fast drying time your main concern?	Yes, and I want no CFC's.	Environmental Cleaner/Degreaser 37501
Is High Dielectric Strength your main concern?	Yes, and I want a good all-purpose cleaner.	F.F. Safety Solvent/Degreaser 37498
	Yes, and I need an economical product.	Electric Motor Degreaser/Safety Solvent 37502
Are you cleaning heavy residue from electric motors?	Yes, and I'm not working around plastics.	Electric Motor Degreaser/Safety Solvent 37502

SPRAYON® CONTACT CLEANERS

Description	SDS Ref #	Part #	Can Size	Net Fill	Std Pk
Electro Wizard™ Electronic Contact Cleaner	S02206000	37680 ★	16 oz	10 oz	12
Plastics Contact Cleaner	S02020000	37504 ★	16 oz	12 oz	12
Electronic Contact Cleaner	SC23020000	37506 ★	16 oz	11 oz	12
Flash Free Safety Solvent and Degreaser*	SC0848T00	37498 ★	20 oz	17 oz	12

*Features High Delivery Nozzle.

★ Made in USA

Sprayon® Electro Wizard™ Electronic Contact Cleaner

37680

A new patent pending formula that instantly removes, dissolves and rinses away foreign contaminants from sensitive equipment and precision instruments. Instant evaporation eliminates trapping of airborne contaminants and allows parts to be handled immediately. Safe on most plastics. D.S. of 12.5 volts. K2 rated, NSF registered.

Sprayon® Plastics Contact Cleaner

37504

Versatile cleaning and degreasing agent that quickly removes light contaminants with no residue and no temperature control problems. Can be applied while equipment is operating because of instant evaporation. Safe on most plastics. D.S. of 19.0 volts. K2 rated, NSF registered.

Sprayon® Electronic Contact Cleaner

37506

Heavy-duty degreaser and quick-drying cleaner. Ideal for sensitive equipment and precision instruments. Fast-evaporating and leaves no residue. For use on non-energized equipment. Safe on most plastics. K2 rated, NSF registered.

Sprayon® Flash Free Safety Solvent

37498

Fast-acting solvent penetrates easily, evaporates quickly and leaves no residue. Excellent cleaning properties make it ideal for removing grease, dirt, wax and metallic particles prevalent in most industrial plants. Non-conductive and non-flammable. Includes extension tube and high delivery nozzle for flush-type applications. D.S. of 37.0 volts. K2 rated, NSF registered.

Uses:

Removes oil, grease, dirt and other contaminants from sensitive equipment, electrical contacts and precision instruments.



You can find access to all current SDS sheets on the Krylon Products Group website.

www.KPG-Industrial.com

SPRAYON® ELECTRICAL & ELECTRONIC CLEANERS & DEGREASERS

Description	SDS Ref #	Part #	Can Size	Net Fill	Std Pk
Flash Free Safety Solvent & Degreaser*	SC0848000	37497	16 oz	13 oz	12
Flash Free Safety Solvent & Degreaser†	SC0848T00	37498 ★	20 oz	17 oz	12
Electrical Cleaner & Lubricating Spray	S02001000	37499	16 oz	16 oz	12
Environmental Cleaner Degreaser	SC0749000	37501 ★	20 oz	15 oz	12
Electric Motor Degreaser/Safety Solvent	S00703000	37502	20 oz	19.25 oz	12
Non-Chlorinated Electrical Degreaser	S02084600	37651	20 oz	18 oz	12

★ Made in USA

*Features Fine Mist Sprayer.

†Features High Flow Valve.

Sprayon® Flash Free Safety Solvent

37497/37498

Fast-acting solvent penetrates easily, evaporates quickly and leaves no residue. Excellent cleaning properties make it ideal for removing grease, dirt, wax and metallic particles prevalent in most industrial plants. Non-conductive and non-flammable. D.S. of 37,000 volts. K2 rated, NSF registered.

Sprayon® Electrical Cleaner & Lubricating Spray

37499

Makes high-precision electrical equipment perform like new. Cleans and penetrates surface pores and leaves a fine microscopic corrosion-proof film. Instant cleaning action cuts cost per application. D.S. of 36,700 volts. K2 rated, NSF registered.

Sprayon® Environmental Cleaner/Degreaser

37501

Designed for fast, effective removal of dirt, oil, grease, wax and tar on electrical equipment. For use on non-energized equipment. Leaves no residue — fast evaporating. K2 rated, NSF registered.

Sprayon® Electric Motor Degreaser

37502

A chlorinated solvent that penetrates quickly to easily lift dirt, grease and tars. Ideal for electrical equipment. Requires no washing or flushing—simply spray on and wipe off. Will not harm insulators or leave a residue. K2 rated, NSF registered.

Uses:

Removes grease, dirt, dust and oxidation residue from electric motors, gears, cables, generators, molds, chains and fuse holders. Some products also apply a corrosion proof film.



You can find access to all current SDS sheets on the Krylon Products Group website.

www.KPG-Industrial.com

Sprayon® Non-Chlorinated Electrical Degreaser

37651

A non-chlorinated, non-flammable, fast-evaporating cleaner penetrates instantly to remove dirt, oil, grease and wax. Increases the life of electrical components by removing foreign materials that can cause costly downtime. Degreases more thoroughly and several times faster than alkaline cleaners. Excellent for degreasing aluminum, cleaning sheet and strip steel prior to galvanizing. D.S. of 15.0 volts. K2 rated, NSF registered.

SPRAYON® LUBRICANTS • SPECIALTY AND GENERAL PURPOSE

Description	SDS Ref #	Part #	Can Size	Net Fill	Std Pk
711® Protector™ Lubricant (Aerosol)	SC0711000	37508 ★	16 oz	11 oz	12
Rust Breaker™ Penetrant	SC0103000	37509 ★	16 oz	10 oz	12
Premium Silicone Lube (6.6%)	S01324000	37510 ★	16 oz	10 oz	12
H. D. Open Gear/Wire Rope Lube	S00201	37511 ★	16 oz	12 oz	12
Cutting Oil	SC0208000	37513 ★	16 oz	12 oz	12

★ Made in USA

Uses:

Reduces friction and stops squeaks and sticking by displacing moisture and repelling water from lugs, bolts, gears, cables, roller chains, machine tools, connectors, linkages and production equipment of all kinds.



Sprayon® 711® Protector™ Lubricant

37508

Excellent choice to penetrate, lubricate, demoiseurize and inhibit corrosion. Ultra-thin, greaseless formulation. Does not attract contaminants. Safe on plastic surfaces. H2 rated, NSF registered. High D.S. 47,000 volts.

Sprayon® Rust Breaker™ Penetrant

37509

Transparent, non-staining oil loosens rust and releases frozen lugs, bolts and tight fitting parts. H2 rated, NSF registered. Won't harm painted surfaces. D.S. of 33,000 volts.

Sprayon® Premium Silicone Lube

37510

6.6% silicone formula stops squeaks and sticking, eliminates friction, repels water and prevents freezing. Does not harden or degrade from -40° to 400°F. Apply to wood, metal, fabric, rubber or leather. Keeps rubber soft and flexible.

Sprayon® Cutting Oil

37513

Extends tool life, reducing tool sharpening and downtime. Recommended for all metals, including stainless steel and soft metals such as aluminum, brass and copper. Clings to surface. Jet-spray allows precision applications. H2 rated, NSF registered.

Sprayon® Heavy Duty Open Gear/Wire Rope Lube

37511

Penetrates to core of wire rope, minimizing internal friction. "Travels" on metal surfaces, displacing water to provide excellent rust protection. Withstands extreme pressure with maximum adhesive and works from 0° to 250°F. Penetrates pores of surfaces without heating. H2 rated, NSF registered.

You can find access to all current SDS sheets on the Krylon Products Group website.

www.KPG-Industrial.com

SPRAYON® & KRYLON® INDUSTRIAL • CORROSION INHIBITORS & INSULATING VARNISHES

- Protects metal surfaces from the damaging effects of corrosive environments.

Description	SDS Ref #	Part #	Can Size	Net Fill	Std Pk
Zinc Rich Cold Galvanizing Compound (Aerosol)	SC0740000	37518 ★	16 oz	14 oz	12
Clear Insulating Varnish	SC0600000	37520 ★	16 oz	14 oz	12
Red Insulating Varnish	SC0601000	37521 ★	20 oz	15.25 oz	12
Long Term Indoor Protectant and Lube	SC0767000	37528 ★	16 oz	11 oz	12
Red Oxide Rust Control Primer	A00339007	37529 ★	16 oz	12 oz	12

★ Made in USA

Sprayon® Zinc Rich Cold Galvanizing Compound

37518

Fast-drying, high-solids, high-performance epoxy based coating. Provides maximum protection to steel exposed to severe corrosive environments. Fuses zinc to the metal substrates to protect against corrosion. Equal to or better than hot-dipped galvanizing. 97% pure zinc dust.

Sprayon® Insulating Varnish

37520/37521

Thoroughly penetrates old and new materials. Air-dries faster than most insulating aerosols. Provides high adhesion, high arc resistance and non-tracking properties. Resists abrasion and wear. D.S. up to 2,200 volts.

Sprayon® Long Term Indoor Protectant and Lube

37528

Penetrates thoroughly and forms a tough, flexible film. High arc resistance and non-tracking properties. Resists oil, water, acids and alkalis. Excellent adhesion.

Krylon® Industrial Tough Coat® Red Oxide Rust Control Primer

37529

Specially formulated for a variety of industrial applications. Ideal for light to heavy duty painting projects, both indoors and outdoors. Smooth, even coverage. Fast drying—dries to the touch in just 15 minutes.



You can find access to all current SDS sheets on the Krylon Products Group website.

www.KPG-Industrial.com

SPRAYON® GENERAL PURPOSE & GLASS CLEANERS



Uses:

Removes grimy dirt, grease and oil from a wide variety of industrial surfaces.

Description	SDS Ref #	Part #	Can Size	Net Fill	Std Pk
General Purpose Cleaner	SC0880000	37524 ★	20 oz	19 oz	12
Heavy Duty Glass Cleaner	SC0880000	37525 ★	20 oz	18 oz	12
Neutra-Force® Heavy Duty Foaming Degreaser	SC1201000	37495 ★	20 oz	19 oz	12

★ Made in USA

Sprayon® General Purpose Cleaner

37524

All-purpose formula that cuts through dirt with ease. Effective and safe to use on metal, finished wood, porcelain, vinyl, leather, laminated surfaces and glass. Cleans spots on synthetic carpets. C1 rated, NSF registered.

Sprayon® Heavy Duty Glass Cleaner

37525

Removes soil, smoke haze, finger prints, road film and surface smears. Cleans any surface not normally harmed by water. Will not cloud plastic materials. Resists streaking—wipes clean. C1 rated, NSF registered.

Sprayon® Neutra-Force® Heavy Duty Foaming Degreaser

37495

A degreaser that delivers fast and effective cleaning on a variety of industrial soils. It contains no caustics, alkali, phosphates, or silicates. Powerful foaming action clings to surface and effectively breaks-down contaminants for effortless removal. Contains no fragrance or dyes and is acceptable as an A1 rated cleaner in food processing facilities.

You can find access to all current SDS sheets on the Krylon Products Group website.

www.KPG-Industrial.com

SPRAYON® INSECTICIDES & INSECT REPELLENTS • INDUSTRIAL GRADE

Description	SDS Ref #	Part #	Can Size	Net Fill	Std Pk
Blast 'Em Wasp & Hornet Spray	S00857000	37522 ★	16 oz	12 oz	12
Blast 'Em Wasp & Hornet Spray	S02085700	37725 ★	20 oz	14 oz	12
Insect Repellent II	S00856000	37523 ★	8 oz	6 oz	12

★ Made in USA

Sprayon® Blast'Em Wasp & Hornet Spray

37522 & 37725

Contains a high amount of petroleum distillates for the best knockdown and kill rate. Residual deposit will kill returning wasps and hornets. Will not harm most plastics. 98% knockdown, 100% kill within 24 hours. D.S. of 33,000 volts. Sprays up to 20 feet. EPA registered.

Sprayon® Insect Repellent II

37523

Effectively repels mosquitoes, chiggers, ticks, deer flies, stable flies, black flies, gnats and fleas. Protects against Lyme disease. Can be applied to skin, clothing and anywhere that insects are a problem. Does not contain R-11. EPA registered.



Uses:
Jobsite protection.

You can find access to all current SDS sheets on the Krylon Products Group website.
www.KPG-Industrial.com

1, 1, 1 Trichloroethane 224

Also called I, I, I trichlor. A chlorinated solvent now banned by the EPA. Sometimes confused with Trichloro-ETHYLENE, a permitted solvent.

Chlorinated Solvents (CFCs & HCFCs)

Common ozone-depleting solvents gradually being phased out by the EPA.

Date Code

Date of production, indicated by a 4-digit code on the bottom of the can. The first 3 digits indicated the numerical day of the year, the 4th digit indicates the year. For example 1818=181st day of 1998 (June 30, 1998). Most paints and chemicals have a shelf life of 3 years from date of manufacture.

Dielectric Strength

A measurement of how well a spray conducts electricity (in Kilovolts per millimeter). A high dielectric strength indicates that a spray is not a good conductor of electricity (which makes it a relatively safe choice for use around electrified equipment). Most low conductivity cleaners will have dielectric strengths ranging from 15,000 to 47,000 (safest).

Flammability

Flammability is rated on a 0 to 4 scale, with 0 being the safest and 4 being the most flammable. This information is printed on each SDS sheet. When selecting a cleaner for degreaser, the first thing you may want to determine is whether the application requires a non-flammable product.

Flash Point

Lowest temperature at which vapors from an aerosol formula will ignite in air when exposed to a flame. When you see a product with a flash point of -20°F this means the most flammable component in the aerosol can ignite at -20°F. The actual aerosol spray, a mixture of a number of chemicals, will generally remain stable to a much higher temperature.

SDS

These sheets list the individual ingredients contained in each product and identify the potential health, fire, explosion and reactivity risks. They also provide a list of precautions and remedies for most common problem situations. A number of government agencies require that these be supplied upon request. You can find access to all current SDS sheets on the Krylon® Products Group website, www.KPG-Industrial.com.

Net Weight

The amount of material that is evacuated or sprayed from the can. It is common in the chemical industry to promote full can weight (which includes propellant). When comparing Krylon® Products Group products with those of other manufacturers, be sure to compare actual net weights.

NSF Registration

Following the 1998 termination of the USDA authorization and listings program for propriety substances and non-food compounds, NSF International was requested to continue the program with advice from USDA. Certain lubricants and cleaners are registered by NSF for use in food manufacturing.

Ozone Depleters

None of our products are class I ozone depleters (the most restricted). Only two are classified II depleters: Safety Cleaner and Degreaser II and Contact Tuner and Cleaner.

Plastic Safe

Some cleaners and degreasers work so well that they dissolve some plastic insulating materials. Plastic safe cleaners, on the other hand, are gentle enough to be applied directly to plastic surfaces.

Residue

This term has two meanings. Some aerosol sprays are designed to leave a fine lubricating film on the machine surface. In common vernacular, *residue* also refers to the sticky film left by a poor-performing product.

Solvency (KB Value)

A measure of how well an electronic cleaner dissolves impurities. The higher the number, the stronger the cleaner; the lower the number, the weaker the cleaning effect. It's important to keep in mind that "weaker" is not necessarily a bad thing. It just means the product is designed to be a more gentle cleaning agent.

Technical Support

If you have a specific application question or are looking for a Krylon® Products Group cross-reference to a competitor's product, please call Krylon® Products Group technical support, Toll Free: (800) 251-2486.

VOC (Volatile Organic Compounds)

These materials are a major contributor to urban smog and some regions have created laws to limit their use, especially in California and the OTC states in the northeastern U.S.

LUMBER CRAYONS

- Use to mark on a variety of surfaces – including metal, wood and plastic.
- Resists smearing and fading from exposure to water and sun.



67404

Color	Part #	Unit	Std Pk
Red	67400 ★	12	144
Yellow	67402 ★	12	144
Blue	67404 ★	12	144
Black	67405 ★	12	144
Lumber Crayon Holder	67410 ★	12	12

★ Made in USA

DURA-INK® 15 BLACK MARKER

This fine bullet tip marker produces accurate and easily readable, thin marks, making it ideal for everything from the shop floor to the shipping room, and parts identification to layout work.

- Black ink contain low halogens.
- Extra tough tip won't spread or mush.
- Smear-resistant, water-resistant, fast-drying.

Applications

- Marks on metal, wood, cardboard, paper, plastic, glass, etc.
- For identification of parts, layout work, and marking cartons and crates.
- Fine point for fine line marking.



Description	Part #	Std Pk
Dura-Ink® 15 Black Marker with Fine Bullet Tip	10030	1*

*48 Piece Canister

WHITE LIGHTNING® SILICONE SEALANT



- Provides a watertight seal.
- Use for interior and exterior projects.
- Highly, permanently flexible.
- Will not crack, crumble or shrink.
- Resists moisture and mildew.
- Excellent adhesion to non-porous materials.
- Not paintable.
- NSF compliant.
- Complies with TT-S-00230C, TTS-001543A, ASTM C-920.

Description	SDS Ref #	Part #	Can Size	Std Pk
100% RTV Silicone Sealant – Clear	WL9010	37530 ★	10 oz	12
100% RTV Silicone Sealant – White	WL9210	37531 ★	10 oz	12

★ Made in USA

EZ-THRUST CAULK GUN



Description	Part #	Std Pk
EZ-Thrust Caulk Gun	96000 ★	1

★ Made in USA

SPRAYON® SILICONE



- Chemically stable.
- Shows little change in physical properties after exposure to sunlight, rain, snow, ozone, temperature extremes and weathering.
- Mildew resistant.
- Long tooling time of 5–10 minutes.
- P1 rated, NSF registered.

Description	Part #	Net Fill	Std Pk
RTV Clear Silicone Sealant	96070 ★	7.25 oz	12
RTV White Silicone Sealant	96071 ★	8 oz	12

★ Made in USA

TRI-FLOW® LUBRICANTS WITH P.T.F.E.



- Lubricates with oils, additives, and P.T.F.E. to reduce friction and increase part life.
- Penetrates inaccessible areas to displace contaminants.
- Rejects dirt, dust, and other abrasive particles.
- Effective from -60° to 475°.
- H2 rated, NSF registered.
- Offers 10 times as much load capacity as WD-40 in a standard Falex-Load Text (ASTM D-233B)

Uses:

- Machinery
- Conveyors
- Bearings
- Cables
- Gears

Description	Container	SDS Ref #	Part #	Can Size	Net Fill
Industrial Lubricant	Aerosol Can	TF20025	37514 ★	8 oz	6 oz
Industrial Lubricant	Trigger Spray Bottle	TF29200	37515 ★	18 oz	18 oz
Industrial Lubricant	Non-Aerosol	TF21010	37516 ★	2 oz	2 oz

★ Made in USA

WHITE LIGHTNING® STOP GAP!™ • EXPANDING FOAM

- Dries tack free in less than 30 minutes.
- Cures in 8 hours.
- Cured product can be trimmed, shaped, sanded, painted or stained.
- Can be applied at temperatures between 60°F and 100°F.
- Great for use on corner and T-joints, exterior sheeting, openings and gaps at the plate line, masonry and concrete or wood walls.



Description	SDS Ref #	Part #	Can Size	Net Fill	Std Pk
Triple Expanding Insulating Foam	WL3333300	96060 ★	16 oz	12 oz	8

★ Made in USA

WET PATCH ROOF CEMENT

- Asbestos free.
- Meets ASTM D4586, ASTM D2822 and Fed Spec SS-C-153C, Type 1.
- Black fibered asphalt mastic works to seal and stop leaks.
- Easy to spread with a small mason's trowel, putty knife or caulking gun.
- Apply at a thickness of ¼" to form a tight weatherproof seal – even sticks in the rain!

Size	SDS Ref #	Part #	Unit	Std Pk
10.3 oz Tube	RC016	96010 ★	1	24
1 Gallon	RC016	96030 ★	1	4

★ Made in USA



E-6000® INDUSTRIAL ADHESIVE • ABRASION RESISTANT SEALANT

- Maintains its adhesion sealant properties even when submerged under water.
- Paintable with water or oil based paints.
- Exceptionally flexible-can stretch to 600% of its length.
- Cures in 8 hours as sealant; 24 hours as an adhesive at 70°.
- 5 year shelf life (unopened).

Uses:

- Sealing circuit boards.
- Sealing junction boxes.
- Insulating electrical connections.
- Re-coating insulating wiring and cables.
- Exceptional adhesion to metal, wood, concrete, glass, masonry, fiber glass and ceramics.
- Adheres to many plastics, leather, rubber and vinyl.

Description	Color	Part #	Tube Size	Box Qty
E-6000® Squeeze Tube	Clear	96040 ★	3.7 oz	12
E-6000® Caulk Tube	Clear	96050 ★	10.2 oz	12
UV-6800 Square Tube	Clear	96140* ★	3.7 oz	12
UV-6800 Caulk Tube	Clear	96150* ★	10.2 oz	12



*UV-6800 works the same as E-6000® but offers special resistance when full sunlight exposure is a concern.

★ Made in USA

DARK CUTTING OIL • FOR CUTTING FERROUS MATERIALS



- Developed for smooth, easy cutting of ferrous materials and ferrous alloys.
- Pleasant to work with. Easy to see with a mild odor.
- May stain non-ferrous materials.

Application	SDS Ref #	Part #	Size	Case Qty
For Cutting Ferrous Materials	TCO 14	96035 ★	Gallon	4

★ Made in USA

DUCT SEAL COMPOUND • EASILY MOLDED • SEALS INSTANTLY



- Seals around conduit openings and junction boxes.
- Adheres to most clean surfaces (for indoor applications).
- Paintable and will not harden.
- Non-conducting, non-toxic, non-corrosive and non-staining.
- UL Listed.
- 1 year shelf life.
- Contact customer service for pallet quantities.

Size	Part #	Unit	Case Qty
1# Plug	14300 ★	1	50
5# Plug	14305 ★	1	10

★ Made in USA

PAINT & CHEMICALS

ALL PURPOSE RAGS • INDUSTRIAL WIPING CLOTHS

Description	Part #	Qty
New Bleached Knits	37580	1 lb Bag of Rags
New Bleached Knits	37582	5 lb Bag of Rags
New Bleached Knits	37584	25 lb Box of Rags
New Bleached Knits	37586	50 lb Box of Rags
Recycled White T-Shirts	37587	25 lb Box of Rags
Recycled White T-Shirts	37588	50 lb Box of Rags
Recycled Colored T-Shirts	37590	25 lb Box of Rags
Recycled Colored T-Shirts	37591	50 lb Box of Rags



SCRUBS-IN-A-BUCKET®

- Citrus-based formula works fast to loosen, dissolve and absorb dirt, grease and grime.
- Perforated high-strength absorbent cleaning towels leave no residue.
- Can be used anywhere on the toughest soils, greases, tar and even ink.
- Safe for use on painted surfaces, composites, tools, equipment, plastics, vinyl and hands.

Safely Removes:

- | | | | | |
|------------|------------|--------------|------------|-------------|
| • Dirt | • Adhesive | • Tar | • Epoxy | • Paint |
| • Sealants | • Oils | • Lubricants | • Urethane | • Ink & Dye |
| • Grease | • Caulk | | | |



Description	Part #	Wipes/Bucket	Std Pk
Scrubs-in-a-Bucket®	37440 ★	72	6

★ Made in USA

FIRESTOP PUTTY PAD



- One pad thickness (1/8") provides a 1 to 2 hour fire rating.
- Meets ASTM E814, UL1479 and ULC/CAN4-S115-M.
- Covers two gang boxes.

Description	Size	SDS REF #	Part #	Case Qty
Firestop Putty Pad	6" x 7" x 1/8" Thick	0216	96230 ★	20

★ Made in USA

LECTRA-STOP™



- One step, one component system.
- Expands to seal openings when exposed to fire.
- Sound rated 55 STC.ASTM E84, UL 723 Tunnel Test. Two hour rating.
- Applies to back of box.
- Intumescent.

Description	SDS REF #	Part #	Case Qty
Lectra-Stop™ Single Gang	0480	96234 ★	50
Lectra-Stop™ Double Gang	0480	96236 ★	50

★ Made in USA

FIRESTOP GASKETS

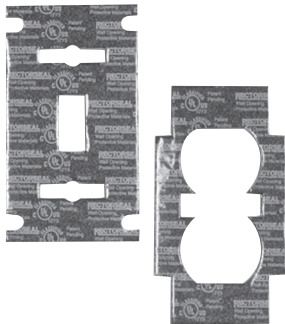

- One step, one component system.
- Expands to seal opening when exposed to fire.
- UL 723 tunnel test. 1 to 2 hour rating.
- Applies between receptacle and cover.
- Intumescent.

Visit www.biofireshield.com for detailed information on fire stopping products.

Description	SDS REF #	Part #	Case Qty
Firestop Gasket Single Receptacle	0591	96238 ★	50
Firestop Gasket Double Receptacle	0591	96240 ★	50
Firestop Gasket Single Switch	0591	96242 ★	50
Firestop Gasket Double Switch	0591	96244 ★	50

★ Made in USA

Intumescent

Firestop products referred to as "intumescent" expand at high temperatures to fill gaps and contain fire and smoke.

FIRESTOP PUTTY STICKS

- Seals around electrical cables, conduit and metal pipes.
- ASTM E814, UL1479 and ULC/CAN4-S115M.
- Two hour rating.



Description	SDS REF #	Part #	Case Qty
Firestop Putty Sticks	0216	96232 ★	12

★ Made in USA

FIRESTOP CAULK

- Intumescent

Description	Rating Size	Case Hours	SDS REF #	Part #	Case Qty
Firestop Caulk 150+	10.3 oz	1-2	0582	96062 ★	24
Firestop Caulk 150+ (Sausage Pack)	20.2 oz	1-2	0582	96064 ★	12
Firestop Caulk 150+	5 Gal	1-2	0582	96066 ★	1
Firestop Caulk 500+	10.3 oz	4	0200	96055 ★	24
Firestop Caulk 500+ (Sausage Pack)	20.2 oz	4	0200	96058 ★	12
Firestop Caulk 500+	5 Gal	4	0200	96059 ★	1
Caulking Gun for Sausage Pack (Blue)			—	96002	1

★ Made in USA



FIRESTOP PILLOWS

Size	Part #	Case Qty
2" x 9" x 6"	96246 ★	10
3" x 9" x 6"	96248 ★	10

★ Made in USA

- Designed for large openings with cables, cable trays, blank openings or multiple penetrating items.
- Three hour rating.
- Most economical firestop pillows available.
- Intumescent.



Size	Blade	Handle	Grip	Weight (lbs)	Part #
Size 2 Round Point Shovel	Hollow Back 8 ⁷ / ₈ " x 11 ³ / ₄ "	47" Fiberglass	Double-Dip	5.00	37250
Size 2 Round Point Shovel	Hollow Back 8 ⁷ / ₈ " x 11 ³ / ₄ "	27" Fiberglass	D-Grip	4.50	37251
Size 2 Square Point Shovel	Hollow Back 8 ⁵ / ₈ " x 11 ¹ / ₄ "	47" Fiberglass	Double-Dip	4.75	37253
Size 2 Mud Round Point Shovel	Hollow Back 8 ³ / ₄ " x 11 ¹ / ₂ "	47" Fiberglass	Double-Dip	4.95	37160
Size 2 Mud Square Point Shovel	Hollow Back 8 ³ / ₄ " x 11 ¹ / ₄ "	47" Fiberglass	Double-Dip	4.95	37161
4" Classic Trench Shovel	Hollow Back 4" x 12"	489 Fiberglass	Double-Dip	3.50	37262
4" Step Trench Shovel	Steel, Forward Step 4" x 11"	47" Fiberglass	Double-Dip	4.00	37163
3" Step Trench Shovel	Steel, Forward Step 3" x 11"	47" Fiberglass	Double-Dip	4.00	37164
5" Step Trench Shovel	Steel, Forward Step 5" x 11"	47" Fiberglass	Double-Dip	4.75	37165
Forged Head 16 Tine Bow Rake	16 ³ / ₄ " x 3" Curved Steel Tines	60" Fiberglass	Double-Dip	4.00	37166
Forged Level Head Rock Rake	16 ³ / ₄ " x 3" Straight Steel Tines	66" Fiberglass	Double-Dip	4.25	37167
Small-Head Irrigating/Floral	Hollow Back 6" x 8 ¹ / ₂ "	46" Fiberglass	Vinyl	2.75	37256
Small-Head Irrigating/Floral	Hollow Back 6" x 8 ¹ / ₂ "	22" Fiberglass	D-Grip	2.00	37257
Small-Head Irrigating/Floral	Hollow Back 6" x 8 ¹ / ₂ "	31" Fiberglass	Vinyl	2.50	37263
14" Drain Spade/Sharp Shooter	Hollow Back 5 ³ / ₄ " x 14"	48" Fiberglass	Double-Dip	5.00	37259
14" Drain Spade/Sharp Shooter	Hollow Back 5 ³ / ₄ " x 14"	30" Fiberglass	D-Grip	4.25	37162
Sledge Hammer	8 lb. Double-Faced Head	36" Fiberglass	None	10.00	37275
Sledge Hammer	10 lb. Double-Faced Head	36" Fiberglass	None	12.00	37277
Sledge Hammer	12 lb. Double-Faced Head	36" Fiberglass	None	14.00	37279
Pick Mattock	5 lbs. Head w/ #6 Eye	36" Fiberglass	None	7.50	37273
48" Utility Probe	3/4" Steel Tip on 1/2" Fiberglass Rod	8 ¹ / ₄ " Fiberglass	Vinyl	1.50	37265
Post Hole Digger	Head 9 ¹ / ₂ " x 6 ¹ / ₂ " w/ 6 ¹ / ₄ " Spread	48" Fiberglass	Double-Dip	10.00	37269
All Purpose Bar w/ Tamper	Forged Wedge 2" x 9"	1" x 48" Steel Pipe	2 ¹ / ₂ " Taper	7.50	37271

Our Handle on Quality



Hollow fiberglass handles may be fine for recreational use but if you must rely on your hand tools everyday, Cully's fiberglass handles have a legacy of premium performance. All Cully handles are produced from thousands of continuous strands of fiberglass saturated with thermosetting resins and non-fiberglass polyester veil impregnated on the surface. The veil gives the handle a smooth finish and keeps the fiberglass from splintering.

Benefits of Fiberglass

- Greater strength pound for point than steel.
- Will not transmit heat or cold, and will not conduct electricity.
- Will not absorb moisture or warp.
- Is non-corrosive and resistant to acids and other chemicals.
- Is highly resistant to temperature changes.
- Resists impact, is non-denting and difficult to damage.
- Minimizes handle breakage and saves on-the-job downtime.

1. Our signature fiberglass handle used on our digging tools

feature a thick wall fiberglass tube, which is less flexible than poly-molded handles, and has a solid fiberglass inner core in the base followed by a hardwood core through the remaining portion of the handle. The solid fiberglass core extends the stress point above the critical neck or collar portion of the handle which increases its overall strength and durability.



2. All of our long handle digging tools feature our new 8-inch Tufoam double-dip grips which have been designed for the toughest industrial applications. The grips feature a durable, vinyl inner liner and a comfortable, non-slip foam exterior that provides long life and helps prevent potential harmful hand fatigue.
3. On tools that require less strength, such as rakes, we use a fiberglass handle with a honeycomb plastic core.
4. Our D-Grips, used on short and midlength handled tools, are made of one-piece high-density nylon.



TOOLS

See page 273 for our shovel display offer!

ELECTRICIAN COMFORT COMBOS



Metal Buckle



Quick Release Buckle



Description	Buckle	Size	Color	MFG #	Part #
Ultimate Electrician Comfort Combo	Metal	Sm 28" – 32"	R. Blue	ULT104RYS	39340 ★
Ultimate Electrician Comfort Combo	Metal	Med 32" – 36"	R. Blue	ULT104RYM	39342 ★
Ultimate Electrician Comfort Combo	Metal	Lg 36" – 40"	R. Blue	ULT104RYL	39344 ★
Ultimate Electrician Comfort Combo	Metal	XL 40" – 44"	R. Blue	ULT104RYXL	39346 ★
Ultimate Electrician Comfort Combo	Metal	Lg 36" – 40"	Black	ULT104BKL	39343 ★
Electrician Comfort Combo	Metal	Med 32" – 36"	Black	104BKM	39370 ★
Electrician Comfort Combo	Metal	Lg 36" – 40"	Black	104BKL	39373 ★
Electrician Comfort Combo	Quick Release	Sm 28" – 32"	R. Blue	100RYS	39348 ★
Electrician Comfort Combo	Quick Release	Med 32" – 36"	R. Blue	100RYM	39350 ★
Electrician Comfort Combo	Quick Release	Lg 36" – 40"	R. Blue	100RYL	39352 ★
Electrician Comfort Combo	Quick Release	XL 40" – 44"	R. Blue	100RYXL	39354 ★

★ Made in USA

POUCHES & BAGS



• The entire Boulder Bag line is available. Contact customer service for quantities and availability.

Description	Color	MFG #	Part #
Ultimate Connect-a-Pouch	Blue	Ult110RY	39336 ★
Ultimate Electrician Tool Pouch	Blue	Ult120RY	39338 ★
7 Pocket Pouch	Blue	110RY	39358 ★
Electrician Tool Pouch	Blue	120RY	39360 ★
Carry-All Bag		830	39368 ★

★ Made in USA

BELTS & SUSPENDERS



39335



39319

Description	Buckle	Size	Color	MFG #	Part #
Comfort Belt	Quick Release	Med 32" – 36"	Black	500M	39318 ★
Comfort Belt	Quick Release	Lg 36" – 40"	Black	500L	39320 ★
Comfort Belt	Quick Release	XL 40" – 44"	Black	500XL	39319 ★
Comfort Belt	Metal	Med 32" – 36"	Black	504M	39322 ★
Comfort Belt	Metal	Lg 36" – 40"	Black	504L	39324 ★
Comfort Belt	Metal	XL 40" – 44"	Black	504XL	39325 ★
Padded Suspenders			Black	527BK	39335 ★

★ Made in USA

ACCESSORIES



39328

Description	Size	Color	MFG #	Part #
Small Meter Pouch	6"H x 2¾"W x 1½"D	Black	141BK	39314 ★
Drill Pouch	10"H x 6"W x 1½"D	Black	440BK	39316 ★
Hammer Holder	—	Black	530BK	39328 ★
Tape Clip	—	Black	545	39356 ★
Phone Case	4"H x 2"W x 1"D	Black	617	39364 ★

★ Made in USA

Electrician Comfort Combo

39348–39354

- Tape Clip (39356)
- 7 Pocket Pouch (39358)
- Hammer Holder (39328)
- Electrician Tool Pouch (39360)
- Comfort Belt with Quick Release Buckle (39318/39320)
- 11 Slots, 14 Pockets
- Quick Release Belt



Ultimate Electrician Comfort Combo

39340–39346

- Ultimate Connect-A-Pouch (39336)
- Hammer Holder (39328)
- Ultimate Electrician Tool Pouch (39338)
- Comfort Belt with Metal Buckle (39322/39324)
- 13 Slots, 19 Pockets
- Metal Buckle



Ultimate Connect-A-Pouch

39336

- Divided Main Compartment
- Large Divided Exterior Pocket
- Interior Pocket
- 2 Connect-A-Pouch Loops
- Upper Velcro Pocket with 4 Elastic Slots



Ultimate Electrician Tool Pouch

39338

- Main Compartment
- 3 Exterior Pockets
- 4 Exterior Slots
- Exterior Tape Pocket
- Interior Utility Knife Pocket
- 6 Interior Pockets
- 3 Interior Slots



7 Pocket Pouch

39358

- Main Compartment
- 2 Interior Pockets
- 2 Large Exterior Pockets
- 2 Exterior Side Pockets



Electrician Tool Pouch

39360

- Divided Main Compartment
- Interior Utility Knife Pocket
- 2 Exterior Pockets
- 6 Exterior Slots
- Interior Pencil Pocket
- Interior Large Pocket
- 5 Interior Slots
- Tape Chain
- Tool Clip



Carry-All-Bag

39368

- 20 Outside Pockets
- 14 Inside Pockets
- Semi-Rigid Construction



MEGAPRO+ 15-IN-1 SCREWDRIVER

Fully Loaded Driver

Description	Part #	Qty
Cully Blue	37200*	1

*Replaces part numbers: 37291, 37292, 37293, 37294, 37295.

Bit Load

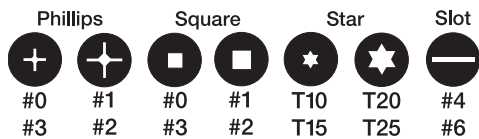

Replacement Bits

Description	Part #	Qty
T10-T15 Star Bit*	40021	1
T20-T25 Star Bit*	40022	1
#0 & #3 Phillips*	40003	1
#1 & #2 Phillips*	40004	1
#0 & #3 Square Drive*	40005	1
#1 & #2 Square Drive*	40006	1
#4 & #6 Slotted Drive*	40007	1
¼ Mag Nut Setter	40008	1
⅝ Mag Nut Setter	40009	1

*Driver comes packed with bits.

TOOLS



MEGAPRO+ 15-IN-1 SCREWDRIVER • STAINLESS STEEL

- Nickel plated bits and stainless steel shaft for a maximum corrosion resistance.
- Great for marine applications, high humidity environments and outdoors.

Fully Loaded Driver

Description	Part #	Qty
Stainless Steel	37285	1

Replacement Bits

Description	Part #	Qty
T10-T15 Star Bit*	40021NP	1
T20-T25 Star Bit*	40022NP	1
#0 & #3 Phillips*	40003NP	1
#1 & #2 Phillips*	40004NP	1
#0 & #3 Square Drive*	40005NP	1
#1 & #2 Square Drive*	40006NP	1
#4 & #6 Slotted Drive*	40007NP	1

*Driver comes packed with bits.

MEGAPRO+ QUICK CHANGE SCREWDRIVER

Description	Part #	Qty
Orange Driver Fully Loaded	37150	1
#0 & #3 Square Drive*	40012	1
#1 & #2 Square Drive*	40013	1
#0 & #3 Phillips*	40014	1
#1 & #2 Phillips*	40015	1
#4 & #6 Slot*	40016	1
T10 & T15 Star*	40017	1
T20 & T25 Star*	40018	1
6" Driver Extension	40019	1
1/4" Socket Adapter	40020	1
6-32 Hex Shank Power Tap**	68036 ★	1
8-32 Hex Shank Power Tap**	68038 ★	1
10-24 Hex Shank Power Tap**	68040 ★	1
10-32 Hex Shank Power Tap**	68044 ★	1
1/4-20 Hex Shank Power Tap**	68046 ★	1
Hex Shank Power Tap Kit (6-32, 8-32, 10-24, 10-32, 1/4-20)**	68096 ★	1

Bit Load						
Phillips		Square		Star		Slot
#0	#1	#0	#1	T10	T20	#4
#3	#2	#3	#2	T15	T25	#6

Quickchange locking coupler works with all 1/4" grooved hex power bits and accessories.

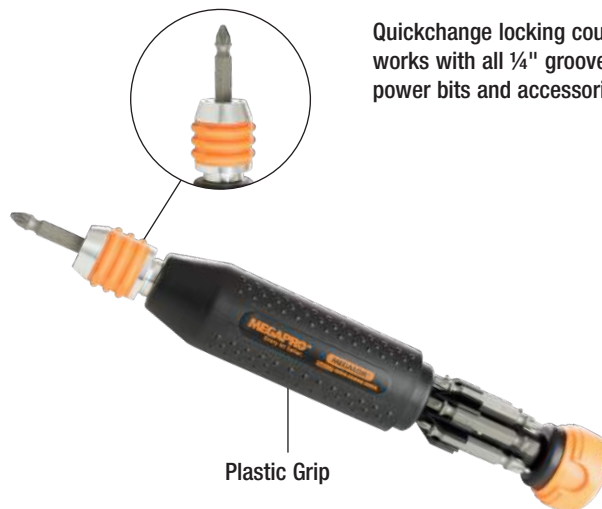

TOOLS

*Driver comes packed with bits.

**Hex Shank Taps are not warranted against breakage.

★ Made in USA

MEGAPRO★ 16-IN-1 SCREWDRIVER • TAMPERPROOF

- Professional grade double-ended 1/4" bits. Hardened to a 59 Rockwell.
- Spring-loaded, ball bearing bit assembly grasps bit snugly every time.
- Solid steel shaft runs the full length of the driver for balance and strength.
- Palm saving rotating cap covers easy access bit compartment.

Fully Loaded Driver

Description	Part #	Qty
Grey	37011	1

Replacement Bits

Description*	Part #	Qty
T10H-T15H Star Pin	69001	1
T20H-T25H Star Pin	69002	1
T27H-T30H Star Pin	69003	1
1/8-9/64 Socket Pin	69004	1
5/32-3/16 Socket Pin	69005	1
#6 & #8 Spanner	69006	1
#10 & #12 Spanner	69007	1
#1 & #2 Square Drive	40006	1

*Driver comes packed with bits.



Bit Load

Spanner		Square	Socket Pin		Star		
#6	#10	#1	1/8	5/32	T10H	T20H	T27H
#8	#12	#2	9/64	3/16	T15H	T25H	T30H

Don't forget Tamperproof Screws. See page 247-248 and 253-254.

See page 130 for our 29-in-1 Tamperproof Driver Bit Kit.

6-IN-1 ECONOMY SCREWDRIVER • QUICK CHANGE



- Quick change bit system with double-ended shaft and bits.
- Ends of shaft serve as two hex drivers.
- Ergonomic handle is comfortable and provides a good gripping surface.

**Free Counter Display with
18 Unit Minimum Purchase!**

Bit Load	Color	Part #	Box Qty
Phillips: #1, #2 Slotted: ¼", ⅜" Hex: ¼", ⅝"	Orange	37014	18
Phillips: #2 Slotted: ¼" Hex: ¼", ⅝" Square Drive: #1, #2	Red	37016	18

13-IN-1 RATCHETING SCREWDRIVER



- Cushion grip
- Retractable bit cartridge
- Palm saver cap

Bit Load	Color	Part #	Qty
Phillips: #0, #1, #2, #3 Slotted: #4, #6 Square Drive: #1, #2 TORX: #10, #15, #20, #25	Red and Black	37020	1

14-IN-1 HVAC SCREWDRIVER



- Plastic grip
- Alloy Steel Shaft
- Palm saver cap
- Easy guide collar
- Retractable bit cartridge

Bit Load	Color	Part #	Qty
Phillips: #0, #1, #2, #3 Slotted: #3, #4, #5, #5.5, #6 Square Awl: Valve Stem	Blue	37021	1

15-IN-1 TAMPERPROOF 2 SCREWDRIVER



- Plastic grip
- Alloy Steel Shaft
- Palm saver cap
- Easy guide collar
- Retractable bit cartridge

Bit Load	Color	Part #	Qty
Tri-Wing: #2, #3, #4, #5 TORX-Plus TR: #10, #15, #20, #25, #27, #30 TORX-Set: #4, #6, #8, #10	Red	37022	1

TOOLS

15-IN-1 SHAFTLOK 2 SCREWDRIVER

- Plastic grip
- Palm saver cap
- Easy guide collar
- Retractable bit cartridge

Bit Load	Color	Part #	Qty
Phillips: #0, #3 Slotted: #4, #6 Square Drive: #0, #1, #2, #3 TORX: #10, #15, #20, #25	Yellow	37023	1



SPANNER DRIVE & UN-DO-IT TOOL

Description	Size	Part #	Unit	Std Pk
Spanner (Snake Eyes) Screwdriver, Plastic Grip	#6	30006TP ★	1	10
Spanner (Snake Eyes) Screwdriver, Plastic Grip	#8	30008TP ★	1	10
Spanner (Snake Eyes) Screwdriver, Plastic Grip	#10	30010TP ★	1	10
Spanner (Snake Eyes) Screwdriver, Plastic Grip	#12	30012TP ★	1	10
Spanner (Snake Eyes) Screwdriver, Plastic Grip	#14	30014TP ★	1	10
One Way Un-Do-It Tool	#6-8	31206 ★	1	10
One Way Un-Do-It Tool	#10-12	31210 ★	1	10
One Way Un-Do-It Tool	#14	31214	1	10

★ Made in USA



30010TP

See page 247 for Stainless Steel.

TOOLS

SQUARE DRIVE SCREWDRIVERS

Description	Overall Length	Size	Screw Size	Color	Part #	Unit
Stubby, Plastic Grip	3"	#2	8, 9, 10	Red	30002	1
Stubby, Plastic Grip	3"	#3	12, 14	Black	30003	1
Midget, Plastic Grip	6½"	#0	3, 4	Yellow	31000	1
Rubber Cushion Grip, Short	7½"	#1	5, 6, 7	Green	35001	1
Rubber Cushion Grip, Short	7½"	#2	8, 9, 10	Red	35002	1
Rubber Cushion Grip, Short	7½"	#3	12, 14	Black	35003	1
Rubber Cushion Grip, Long	10"	#1	5, 6, 7	Green	34001	1
Rubber Cushion Grip, Long	10"	#2	8, 9, 10	Red	34002	1
Rubber Cushion Grip, Long	10"	#3	12, 14	Black	34003	1



34001

30002

BLISTER PACK SPANNER BITS



Description	Part #	Pkg Qty (per card)
#6 Spanner Bit, ¼ Hex	31106D	2
#8 Spanner Bit, ¼ Hex	31108D	2
#6-#8 Double-Ended Spanner Bit	69006D	2
#10-#12 Double-Ended Spanner Bit	69007D	2

TOOLS

BLISTER PACK SQUARE DRIVE/HEX POWER BITS



Size	Length	Screw Size	Part #	Pkg Qty (per card)
#1	1	#5-6	38101D	2
#1	2	#5-6	38102D	2
#1	3	#5-6	38103D	1
#1	4	#5-6	38104D	1
#2	1	#8-10	38201D	2
#2	2	#8-10	38202D	2
#2	3	#8-10	38203D	1
#2	4	#8-10	38204D	1
#2	6	#8-10	38206D	1
#3	1	#12-14	38301D	2
#3	2	#12-14	38302D	2
#3	3	#12-14	38303D	1
#3	4	#12-14	38304D	1
#3	6	#12-14	38306D	1

BLISTER PACK SQUARE/PHILLIPS DOUBLE ENDED POWER BITS

Description	Part #	Pkg Qty (per card)
Double Ended Power Bit: #2 Square Drive, #2 Phillips	38215D	2



BLISTER PACK PHILLIPS/HEX POWER BITS

Size	Length	Part #	Pkg Qty (per card)
#1	1	38401D	2
#1	2	38402D	2
#1	6	38406D	1
#2	1	38501D	2
#2	2	38502D	2
#2	3	38503D	1
#2	4	38504D	1
#2	6	38506D	1
#3	1	38601D	2
#3	2	38602D	2
#3	3	38603D	1



TOOLS

BLISTER PACK SLOTTED/HEX POWER BITS

Size	Length	Part #	Pkg Qty (per card)
8-10	1	38561D	2
8-10	2	38562D	2
8-10	3	38563D	1



BLISTER PACK HEX DRIVER BITS • MAGNETIC



39004D
1/4 x 1-3/4"
Hex Driver Bits
#6-8 - Magnetic



39015D
1/8 x 2"
Magnetic
BIT HOLDER

Size	Length	Screw Size	Part #	Pkg Qty (per card)
1/4	1 3/4	#6-8	39004D	2
5/16	1 3/4	#10-12	39005D	2
3/8	1 3/4	#14	39006D	2
1/4	2 9/16	#6-8	39014D	1
5/16	2 9/16	#10-12	39015D	1
3/8	2 9/16	#14	39016D	1
1/4	4	#6-8	39024D	1
5/16	4	#10-12	39025D	1
3/8	4	#14	39026D	1
1/4	6	#6-8	39034D	1
5/16	6	#10-12	39035D	1
3/8	6	#14	39036D	1

Description	Part #	Pkg Qty (per card)
Magnetic Bit Holder - 1/4 x 3	39018D	1

BLISTER PACK HEX BOLT DRIVER



Size	Part #	Pkg Qty (per card)
1/4-20 x 2 9/16	39101D	1
3/8-16 x 2 9/16	39103D	1

BLISTER PACK STAR PIN BIT



Description	Part #	Pkg Qty (per card)
T10H-T15H	69001D	2
T20H-T25H	69002D	2
T27H-T30H	69003D	2

BLISTER PACK SOCKET PIN HEX BIT



Description	Part #	Pkg Qty (per card)
1/8-9/64 Socket	69004D	2
5/32-3/16 Socket	69005D	2

BLISTER PACK JOBBER DRILLS/JOBBER SPLIT POINTS

Jobber Drills 118° Point		
Size	Part #	Pkg Qty (per card)
1/16	91601D	2
5/64	91602D	2
3/32	91603D	4
7/64	91604D	4
1/8	91605D	4
9/64	91606D	4
5/32	91607D	4
11/64	91608D	2
3/16	91609D	2
13/64	91610D	2
7/32	91611D	2
15/64	91612D	2
1/4	91613D	2
5/16	91617D	1
3/8	91621D	1
7/16	91625D	1
1/2	91629D	1
#7	91707D	1
#21	91721D	1
#25	91725D	1
#29	91729D	1
#36	91736D	1

Jobber Drills 135° Point		
Description	Part #	Pkg Qty (per card)
1/16	91901D	2
5/64	91902D	2
3/32	91903D	4
7/64	91904D	4
1/8	91905D	4
9/64	91906D	4
5/32	91907D	2
11/64	91908D	2
3/16	91909D	2
13/64	91910D	2
7/32	91911D	2
15/64	91912D	2
1/4	91913D	2
17/64	91914D	1
9/32	91915D	1
19/64	91916D	1
5/16	91917D	1
21/64	91918D	1
11/32	91919D	1
23/64	91920D	1
3/8	91921D	1
25/64	91922D	1
13/32	91923D	1
27/64	91924D	1
7/16	91925D	1
29/64	91926D	1
15/32	91927D	1
31/64	91928D	1
1/2	91929D	1



TOOLS

TAMPERPROOF KIT • 29-IN-1 DRIVER KIT



37009

- 29 piece assortment of security bits includes star pin, socket pin, tri-wing, torq-set bit, square drive and spanner bit.
- Features a magnetic hand driver with storage case.
- Includes a magnetic holder for power driving!

This is one of the most complete tamperproof screwdriver kits available anywhere with all of the most common and many of the rarest bits.

Description	Size	Part #	Qty
29-In-1 Driver TamperProof Kit	—	37009	1
Socket Adapter	1"	92600 ★	1
Magnetic Bit Holder	3"	92602 ★	1





38988



92706

Spanner Bit 	
Size	Part #
#6	31106 ★
#8	31108 ★
#10	31110 ★

Tri-Wing 	
Size	Part #
#1	38705 ★

Socket Pin 	
Size	Part #
1/8"	92706 ★
9/64"	92707 ★
5/32"	92709 ★
3/16"	92710 ★
7/32"	92711 ★
1/4"	92718 ★
5/16"	92720 ★

★ Made in USA

Star Pin 	
Size	Part #
T-8H	38983 ★
T-9H	38984 ★
T-10H	38985 ★
T-15H	38988 ★
T-20H	38990 ★
T-25H	38992 ★
T-27H	38994 ★
T-30H	38996 ★
T-40H	38998 ★

Pozi Drive 	
Size	Part #
#1	92500 ★

Don't forget Tamperproof Screws.
See pages 247-248, 253-254.
See page 123 for our 16-in-1 Tamperproof Screwdriver.

TOOLS

CARBIDE-TIPPED MASONRY DRILL BITS



Size	Part #	Box Qty	Master Carton
5/32 X 3 1/2	61105	1	10
5/32 X 4 1/2	61107	1	10
5/32 X 5 1/2	61108	1	10
3/16 X 3 1/2	61109	1	10
3/16 X 4 1/2	61111	1	10
3/16 X 5 1/2	61113	1	10

Installation

1. Drill a hole 1/2" deeper than the screw embedment.
2. Clean hole of all debris.
3. Insert the screw through the fixture and into the hole.
4. Drive the screw slowly, allowing the threads to tap into the base material.

DIAL-A-BIT KIT • SLOTTED, PHILLIPS & SQUARE DRIVE

- Includes a magnetic bit holder for power driving.
- Magnetic bit holder inserts into star hole at top of the bit case to become a screwdriver handle.



Description	Part #	Qty
10 Piece Kit	39917 ★	1

Description	Part #
¼" Magnetic Bit Holder	92602 ★

Phillips	
Size	Part #
#1	38401
#2	38501
#3	38601 ★

Slotted	
Size	Part #
#6	38648
#8	38561 ★
#10	38661 ★

Square	
Size	Part #
#1	38101
#2	38201
#3	38301

★ Made in USA

DRIVER BIT ACCESSORIES

Description	Overall Length	Part #	Unit
Magnetic Bit Holder	¼" x 3"	39018	1



Description	Part #	Unit
Double Ended Power Bit: #2 Square Drive, #2 Phillips	38215	1
Double Ended Power Bit: Bucket O' Bits	38222	125



Description	Part #	Unit
Magnetizer/Demagnetizer	40010	1



QUICK CHANGE DRILL ADAPTER

- Turns a standard drill into a keyless chuck for 2"+ longer power bits.
- Can also be used with hex shank drill bits (page 154).

Description	Part #	Unit
Quick Change Drill Adapter	39020 ★	1



★ Made in USA

SQUARE DRIVE HEX POWER BITS • 1/4" HEX SHANK



- All bits 1" length are insert bits.
- All bits over 1" length are sold as hex power bits.

Size	Length	Screw Size	Plastic Bag		5 Pk Clamshell		Bucket O' Bits	
			Part #	Qty	Part #	Qty	Part #	Jar Qty
#0	1	#4	38001	1	—	—	—	—
#0	2	#4	38002	1	—	—	—	—
#0	3	#4	38003	1	—	—	—	—
#1	1	#5-6	38101	1	—	—	—	—
#1	2	#5-6	38102	1	—	—	—	—
#1	3	#5-6	38103	1	—	—	—	—
#1	4	#5-6	38104	1	—	—	—	—
#1	6	#5-6	38106	1	—	—	—	—
#2	1	#8-10	38201	1	38201-5	5	38200	250
#2	2	#8-10	38202	1	38202-5	5	38220	125
#2	3	#8-10	38203	1	38203-5	5	—	—
#2	4	#8-10	38204	1	—	—	—	—
#2	6	#8-10	38206	1	—	—	—	—
#2	10	#8-10	38210	1	—	—	—	—
#2	12	#8-10	38212	1	—	—	—	—
#3	1	#12-14	38301	1	38301-5	5	—	—
#3	2	#12-14	38302	1	38302-5	5	—	—
#3	3	#12-14	38303	1	—	—	—	—
#3	4	#12-14	38304	1	—	—	—	—
#3	6	#12-14	38306	1	—	—	—	—
#3	8	#12-14	38308	1	—	—	—	—

TOOLS

PHILLIPS HEX POWER BITS • 1/4" HEX SHANK



Size	Length	Plastic Bag		5 Pk Clamshell		Bucket O' Bits	
		Part #	Qty	Part #	Qty	Part #	Jar Qty
#1	1	38401	1	—	—	—	—
#1	2	38402	1	—	—	—	—
#1	3	38403	1	—	—	—	—
#1	4	38404	1	—	—	—	—
#1	6	38406	1	—	—	—	—
#2	1	38501	1	38501-5	5	38500	250
#2	2	38502	1	38502-5	5	38520	125
#2	3	38503	1	38503-5	5	—	—
#2	4	38504	1	—	—	—	—
#2	6	38506	1	—	—	—	—
#3	1	38601 ★	1	—	—	—	—
#3	2	38602	1	38602-5	5	—	—
#3	3	38603 ★	1	—	—	—	—
#3	4	38604 ★	1	—	—	—	—
#3	6	38606 ★	1	—	—	—	—

★ Made in USA

SLOTTED HEX POWER BITS • 1/4" HEX SHANK

		Plastic Bag	
Size	Length	Part #	Qty
#6-7	2	38642 ★	1
#8-10	1	38561 ★	1
#8-10	2	38562	1
#8-10	3	38563	1
#8-10	4	38564	1
#10-12	1	38661 ★	1
#10-12	2	38662	1



★ Made in USA

HEX DRIVER BITS • MAGNETIC

			Plastic Bag		3 Pk Clamshell		Bucket 0' Bits	
Size	Length	Screw Size	Part #	Qty	Part #	Part #	Jar Qty	
1/4	1 1/4	#6-8	39004	1	39004-5	3	39104	50
1/4	3		39014	1	39014-5	3	39114	25
1/4	4		39024 ★	1	—	—	—	—
1/4	6		39034 ★	1	—	—	—	—
5/16	1 3/4	#10-12	39005	1	39005-5	3	39105	50
5/16	2-9/16		39015	1	39015-5	3	39115	25
5/16	4		39025 ★	1	—	—	—	—
5/16	6		39035 ★	1	—	—	—	—
3/8	1 3/4	#14	39006	1	—	—	39106	50
3/8	3		39016	1	—	—	—	—
3/8	4		39026 ★	1	—	—	—	—
3/8	6		39036 ★	1	—	—	—	—



★ Made in USA

TOOLS

TAMPERPROOF INSERT BITS • STAR, SPANNER & SOCKET PIN

Star Pin			
Size	Shank Size	Part #	Qty
T-8H	¼ Hex	38983 ★	1
T-9H	¼ Hex	38984 ★	1
T-10H	¼ Hex	38985 ★	1
T-15H	¼ Hex	38988 ★	1
T-20H	¼ Hex	38990 ★	1
T-25H	¼ Hex	38992 ★	1
T-27H	¼ Hex	38994 ★	1
T-30H	¼ Hex	38996 ★	1
T-40H	¼ Hex	38998 ★	1
T-50H	¼ Hex	38999	1

Spanner Head				
Size	Length	Shank Size	Part #	Qty
#6	1	¼ Hex	31106 ★	1
#8	1	¼ Hex	31108 ★	1
#10	1	¼ Hex	31110 ★	1
#12	1	⅝ Hex	31112 ★	1
#14	1	⅝ Hex	31114	1

Tri-Wing Bits				
Size	Length	Shank Size	Part #	Qty
#4	1	¼ Hex	38704 ★	1
#5	1	¼ Hex	38705 ★	1

Socket Pin			
Size	Shank Size	Part #	Qty
⅛	¼ Hex	92706 ★	1
9/64	¼ Hex	92707 ★	1
5/32	¼ Hex	92709 ★	1
3/16	¼ Hex	92710 ★	1
7/32	¼ Hex	92711 ★	1
¼	¼ Hex	92718 ★	1
5/16	¼ Hex	92720 ★	1

★ Made in USA

See Tamperproof Screws pages 247-248, 253-254.

TOOLS

HIGH SPEED JOBBER DRILLS • 118° POINT • STEEL

- Made from high speed tool steel.
- Polished flute for fast chip removal.
- 118° point, the economical choice.

Size	Part #	Pkg Qty
1/64	91597	12
1/32	91599 ★	12
3/64	91600 ★	12
1/16	91601 *	12
5/64	91602 *	12
3/32	91603 *	12
7/64	91604 *	12
1/8	91605 *	12
9/64	91606 *	12
5/32	91607 *	12
11/64	91608 *	12
3/16	91609 *	12
13/64	91610 *	12
7/32	91611 *	12
15/64	91612 *	12
1/4	91613 *	12
17/64	91614 *	12
9/32	91615 *	12

Size	Part #	Pkg Qty
19/64	91616	6
5/16	91617 *	6
21/64	91618 *	6
11/32	91619 *	6
23/64	91620 *	6
3/8	91621 *	6
25/64	91622 *	6
13/32	91623 *	6
27/64	91624 *	6
7/16	91625 *	6
29/64	91626 *	6
15/32	91627 *	6
31/64	91628 *	6
1/2	91629 *	6
#7	91707 ★	12
#21	91721 ★	12
#25	91725 ★	12
#29	91729 ★	12



TOOLS

★ Made in USA

*To set up display order one package of each asterisked item.

118° Metal Index Set			
Size	Part #	Number of Pieces	Pkg Qty
1/16–1/4 x 64ths	91801	13	1
1/16–1/2 x 64ths	91806	29	1



HIGH SPEED JOBBER DRILLS • 135° POINT • STEEL



- 135° split point is self-centering, reducing thrust.
- Better performance for just a few cents more than a 118° point.

TOOLS

Size	Part #	Pkg Qty
1/16	91901	12
5/64	91902	12
3/32	91903	12
7/64	91904	12
1/8	91905	12
9/64	91906	12
5/32	91907	12
11/64	91908	12
3/16	91909	12
13/64	91910	12
7/32	91911	12
15/64	91912	12
1/4	91913	12
17/64	91914	12
9/32	91915	12

Size	Part #	Pkg Qty
19/64	91916	6
5/16	91917	6
21/64	91918	6
11/32	91919	6
23/64	91920	6
3/8	91921	6
25/64	91922	6
13/32	91923	6
27/64	91924	6
7/16	91925	6
29/64	91926	6
15/32	91927	6
31/64	91928	6
1/2	91929	6



135° Metal Index Set			
Size	Part #	Number of Pieces	Pkg Qty
1/16–3/8 x 32nds	91802	15	1
1/16–1/4 x 64ths	91945	13	1
1/16–1/2 x 64ths	91949	29	1

TRINADO HEAVY-DUTY DRILLS • 135° POINT

Size	Description	Part #	Qty
13/64	3 Flat Shank	33313 ★	12
7/32	3 Flat Shank	33314 ★	12
15/64	3 Flat Shank	33315 ★	12
1/4	3 Flat Shank	33316 ★	12
17/64	3 Flat Shank	33317 ★	12
9/32	3 Flat Shank	33318 ★	12
19/64	3 Flat Shank	33319 ★	12
5/16	3 Flat Shank	33320 ★	6
21/64	3 Flat Shank	33321 ★	6
11/32	3 Flat Shank	33322 ★	6
23/64	3 Flat Shank	33323 ★	6
3/8	3 Flat Shank	33324 ★	6
25/64	3 Flat Shank	33325 ★	6
13/32	3 Flat Shank	33326 ★	6
27/64	3 Flat Shank	92627 ★	6
7/16	3 Flat Shank	92628 ★	6
29/64	3 Flat Shank	92629 ★	6
15/32	3 Flat Shank	92630 ★	6
31/64	3 Flat Shank	92631 ★	6
1/2	3 Flat Shank	92632 ★	6

Size	Description	Part #	Qty
1/16	Straight Shank	33304 ★	12
5/64	Straight Shank	33305 ★	12
3/32	Straight Shank	33306 ★	12
7/64	Straight Shank	33307 ★	12
1/8	Straight Shank	33308 ★	12
9/64	Straight Shank	33309 ★	12
5/32	Straight Shank	33310 ★	12
11/64	Straight Shank	33311 ★	12
3/16	Straight Shank	33312 ★	12

★ Made in USA



TOOLS

TRINADO HEAVY-DUTY DRILLS • METAL INDEX SET

- Black and bronze oxide surface treatments reduce friction.
- M7 industrial steel withstands high temperatures, maintains sharpness.
- Excellent for drilling in stainless and high carbon steels.

Size Range	No. Pcs	Part #	Qty
1/16–1/4 x 32nds	13	33333 ★	1
1/16–3/8 x 64ths	21	33335 ★	1
1/16–1/2 x 64ths	29	33336 ★	1

★ Made in USA



HEX DRILL SET • 135° SPLIT POINTS WITH HEX SHANKS • 7 PIECES



- Use a Quick-Change Drill Adapter (#39020) with hex shank drills to speed up interchange without needing to use drill chuck.

Size Range	No. Pcs	Part #	Qty
$\frac{1}{16}$ – $\frac{3}{32}$ – $\frac{1}{8}$ – $\frac{5}{32}$ – $\frac{3}{16}$ – $\frac{7}{32}$ – $\frac{1}{4}$	7	45432 ★	1

★ Made in USA

SPECIAL DRILL SETS • COBALT & TITANIUM DRILLS



Description	No. Pcs	Part #	Qty
Cobalt Drill Set (Gold) $\frac{1}{16}$ – $\frac{1}{4}$ x 64ths	13	91805	1
Titanium Drill Set (Yellow) $\frac{1}{16}$ – $\frac{1}{4}$ x 64ths	13	91807	1

STRAIGHT SHANK CARBIDE DRILL BITS • ROTARY ONLY

Hole Size	Length	Part #	Pkg Qty
3/16	4	59904 ★	1
1/4	4	59906 ★	1
1/4	6	59908	1
5/16	4	59910	1
5/16	6	59912	1
3/8	4	59914	1
3/8	6	59916	1
1/2	4	59918	1
1/2	6	59920	1
5/8	6	59922	1

- Straight shank design. Our most economical carbide bits.
- Fits any portable rotary drill or drill press – up to 1000 RPM.
- The right solution for drilling holes in tile, brick, block or cement.

★ Made in USA



PERCUSSION CARBIDE DRILL BITS

Hole Size	Overall Length	Part #	Pkg Qty
1/8	3	59720	1
3/16	3 1/2	59722	1
1/4	4	59724	1
1/4	6	59726	1
5/16	4 3/4	59728	1
5/16	6	59730	1
3/8	4	59732	1
3/8	6	59734	1
1/2	6	59736	1
5/8	6	59738	1
3/4	6	59740	1

- Percussion Grade



SDS ROTARY/HAMMER CARBIDE DRILL BITS

Hole Size	Overall Length	Part #	Pkg Qty
3/16	4 1/2	59980	1
3/16	6 1/4	59982	1
1/4	4 1/2	59984	1
1/4	6 1/2	59986	1
1/4	14	59996	1
5/16	6 1/2	59987	1
3/8	6 1/2	59988	1
3/8	12 1/2	59998	1
1/2	6	59990	1
1/2	14	59991	1
5/8	8 1/4	59992	1
3/4	8	59994	1



BELL HANGER BITS • WIRING INSTALLATIONS • HIGH SPEED



		 Plastic Bag	
Hole Size	Length	Part #	Pkg Qty
1/4	12	82204	1
5/16	12	82205	1
3/8	12	82206	1
7/16	12	82207	1
1/2	12	82208	1
3/16	18	82303	1
1/4	18	82304	1
5/16	18	82305	1
3/8	18	82306	1
7/16	18	82307	1
1/2	18	82308	1
1/4	24	82404	1
5/16	24	82405	1
3/8	24	82406	1
1/2	24	82408	1

- Heat treated steel bits for maximum strength and durability.
- Perfect for boring through wood, metal, plaster and particle board.
- Hole in head of bit for easy pulling of wire.

Installation

- Drill a hole through walls, ceiling or floor.
- Attach wire through the hole at the end of the bell hanger.
- Withdraw drill and pull wire through.

FLEX SHANK DRILL BITS (FISH BITS) • SELF-FEED SCREW POINT



		 Plastic Bag	
Hole Size	Length	Part #	Pkg Qty
3/8	54	92050	1
1/2	54	92052	1
9/16	54	92054	1
3/4	54	92056	1
3/8	72	92051	1
1/2	72	92053	1
9/16	72	92055	1
3/4	72	92057	1
Fish Bit Steering Guide		92058	1

- Self-feeding screw point is brazed to a flexible spring steel shaft.
- Perfect for drilling holes and pulling wires and cables through walls, ceilings and floors.
- Steering guide bends and directs the fish bit in the right position.

ELECTRICIAN'S POWER BITS • SELF-FEEDING SCREW POINT



			 Plastic Bag	
Hole Size	Length	Hex Shank	Part #	Pkg Qty
5/8	8 1/2	5/16	80910	1
11/16	8 1/2	5/16	80911	1
3/4	8 1/2	5/16	80912	1
13/16	8 1/2	5/16	80913	1
7/8	8 1/2	5/16	80914	1
1	8 1/2	5/16	80916	1
1 1/8	8 1/2	5/16	80918	1
1 1/4	8 1/2	5/16	80920	1

- Single spur double twist drill with self-feeding screw point.

8" SHIP AUGER BITS • HEX SHANK • HEAT TREATED STEEL

- Single twist with self-feeding screw point cuts smoothly through wood.
- Super strong heat treated steel cuts through nails and other materials.
- Hollow center designed for fast flow of chips.
- Can be sharpened with a Cully™ auger bit sharpening file (Part #09382).

Hole Size	Length	Hex Shank	Part #	Pkg Qty
1/2	8	5/16	80608	1
9/16	8	7/16	80609	1
5/8	8	7/16	80610	1
3/4	8	7/16	80612	1
13/16	8	7/16	80613	1
7/8	8	7/16	80614	1
15/16	8	7/16	80615	1
1	8	7/16	80616	1
1 1/8	8	7/16	80618	1
1 1/4	8	7/16	80620	1
1 3/8	8	7/16	80622	1
1 1/2	8	7/16	80624	1

Same as Bell Hanger packaging.



17" SHIP AUGER BITS • HEX SHANK • HEAT TREATED STEEL

Hole Size	Length	Hex Shank	Part #	Pkg Qty
3/8	17	5/16	81806	1
7/16	17	5/16	81807	1
1/2	17	5/16	81808	1
9/16	17	5/16	81809	1
5/8	17	5/16	81810	1
1 1/16	17	7/16	81811	1
3/4	17	7/16	81812	1
13/16	17	7/16	81813	1
7/8	17	7/16	81814	1
15/16	17	7/16	81815	1
1	17	7/16	81816	1
1 1/16	17	7/16	81817	1
1 1/8	17	7/16	81818	1
1 1/4	17	7/16	81820	1
1 3/8	17	7/16	81822	1
1 1/2	17	7/16	81824	1

Same as Bell Hanger packaging.



AUGER BIT EXTENSIONS & SHARPENING FILE

- Heavy duty, features a double-set screw lock, adds 9 1/2" to 24" to your bits.

Description	Length	Hex Shank	Part #	Pkg Qty
Auger Bit Extension	9 1/2	7/16	82009	1
Auger Bit Extension	12	7/16	82012	1
Auger Bit Extension	18	7/16	82018	1
Auger Bit Extension	24	7/16	82024	1
Auger Sharpening File	7	—	09382	1

Same as Bell Hanger packaging.



SAWTOOTH SELF-FEEDING BITS • THREE MILLED FLATS



Hole Size	Length	Part #	Pkg Qty
1 $\frac{3}{8}$	5	86922 ★	1
1 $\frac{1}{2}$	5	86924 ★	1
1 $\frac{3}{4}$	5	86928 ★	1
2 $\frac{1}{8}$	5	86934 ★	1
2 $\frac{9}{16}$	5	86941 ★	1
3 $\frac{5}{8}$	5	86958 ★	1

- Open design whisks away wood chips.
- Fine thread screw point provides excellent control.
- Tapered for easy removal.

★ Made in USA

SPEEDBOR 2000™ WOOD BITS • IRWIN 2000

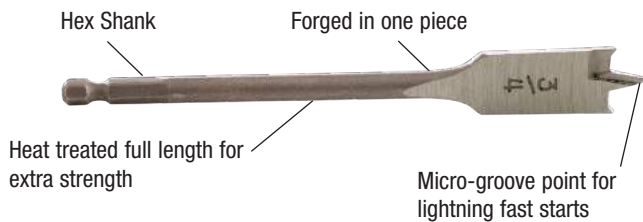

Hole Size	Length	Part #	Pkg Qty
1/4	6	85004 ★	1
5/16	6	85005 ★	1
3/8	6	85006 ★	1
7/16	6	85007 ★	1
1/2	6	85008 ★	1
9/16	6	85009 ★	1
5/8	6	85010 ★	1
11/16	6	85011 ★	1
3/4	6	85012 ★	1
13/16	6	85013 ★	1
7/8	6	85014 ★	1
15/16	6	85015 ★	1
1	6	85016 ★	1
1 $\frac{1}{8}$	6	85018 ★	1
1 $\frac{1}{4}$	6	85020 ★	1
1 $\frac{3}{8}$	6	85022 ★	1
1 $\frac{1}{2}$	6	85024 ★	1
12" Extension		88602 ★	1
6" Extension		88703 ★	1

- Extended spurs scribe the hole for faster chip clearance.
- Precision-ground shanks run true with no run-out or wobble.
- Fits 1/4" and larger power drives.
- Micro-groove point moves quickly through hardwood, softwood, plywood and drywall.

★ Made in USA

STEP DRILLS • 2-FLUTE SPLIT TIP DESIGN • HIGH SPEED STEEL

- Will drill through 10 gauge mild steel or stainless steel.
- Three flats shank for non-slip grip.
- Self-drilling. Requires no pre-punching.



Applications

- Metal Studs
- Switch Boxes
- Junction Boxes
- Lighting
- Fixtures

Hole Size Range	Increments	Number of Steps	Shank Size	Step Thickness	Part #	Pkg Qty
1/8-1/2	1/32	13	1/4	1/8	86708	1
1/4-3/4	1/16	9	3/8	1/8	86712	1
3/16-7/8	1/16	12	3/8	1/8	86714	1
7/16-1 1/8	1/16	12	3/8	1/8	86718	1
3/4-1 3/8	1/16	11	3/8	1/8	86722	1
1/4-1 1/2	1/16	11	3/8	1/8	86724	1

HOLE SAW ARBORS & PILOT DRILLS

Description	Shank/Thread	Thread Size	Fits Saws	Pilot Bit Size (MAPD3)	Pin Drive	Part #	Qty
Arbors	1/4 Hex	1/2-20	9/16"-1-3/16"	3-3/32"	No	86561 ★	1
Arbors	3/8 Hex	1/2-20	9/16"-1-3/16"	3-3/32"	No	86562 ★	1
Arbors	3/8 Hex	5/8-18	1 -1/4"-6"	3-3/32"	Yes	86563 ★	1
Arbors	7/16 Hex	5/8-18	1 -1/4"-6"	3-3/32"	Yes	86564 ★	1
1/4 x 4 1/2 Pilot Drill	—	—	—	—	—	86511 ★	1
1/4 x 3 1/16 (M24) Pilot Drill	—	—	—	—	—	86514 ★	1
12" Arbor Extension	—	—	—	—	—	86512 ★	1



*Includes a 1/4" pilot drill.

★ Made in USA

VARIABLE PITCH HOLE SAWS • BI-METAL • 4-6 PITCH



- Variable pitch (4 and 6 teeth per inch). Cuts 45% faster than a conventional 6-pitch saw.
- 1½" cutting depth – Designed for use in wood, plastic, steel, tin, aluminum and fiberglass.

Hole Size	Arbor #	Part #	Qty
9/16	86561★ or 86562★	86209★	1
3/4		86212★	1
7/8		86214★	1
1		86216★	1
1 1/16		86217★	1
1 1/8		86218★	1
1 3/16	86563★ or 86564★	86219★	1
1 1/4		86220★	1
1 3/8		86222★	1
1 1/2		86224★	1
1 5/8		86226★	1
1 3/4		86228★	1
2		86232★	1
2 1/8		86234★	1
2 1/4		86236★	1
2 3/8		86238★	1

★ Made in USA

Hole Size	Arbor #	Part #	Qty
2 1/2	86563★ or 86564★	86240★	1
2 5/8		86242★	1
2 3/4		86244★	1
2 7/8		86246★	1
3		86248★	1
3 1/4		86252★	1
3 3/8		86254★	1
3 1/2		86256★	1
3 5/8		86258★	1
3 3/4		86260★	1
4		86264★	1
4 1/8		86266★	1
4 1/4		86268★	1
4 3/8		86270★	1
4 1/2		86272★	1
4 3/4		86276★	1
5		86280★	1
5 1/4		86284★	1
5 1/2	86288★	1	
5 3/4	86292★	1	
6	86296★	1	
6 5/8	86298★	1	

Premium Morse Real McCoy (TA) Hole Saws with built-in arbors available by special order.

See display offer on page 366

TOOLS

ELECTRICIAN'S HOLE SAW KIT



- Kit contains 6 of the most popular variable pitch hole saws.
- Packaged in a durable plastic carrying case.

Kits				
Part #	Description			
86522★ (8 Piece Kit)	Pipe Entrance Kit For Pipe 1/2"-2"			
	7/8" Hole Saw	1 3/8" Hole Saw	2" Hole Saw	M44 Arbor
	1 1/8" Hole Saw	1 3/4" Hole Saw	2 1/2" Hole Saw	M45P Arbor

★ Made in USA

MASTER ELECTRICIAN'S HOLE SAW KIT

- Kit contains 10 of the most popular variable pitch hole saws.
- Includes two 7/16" hex arbors – 1/2-20 and 5/8-18 and a 1/4 round 1/2-20 arbor.

		 Kits		
Part #	Description			
86528 ★ (13 Piece Kit)	Pipe Entrance Kit – For Pipe 1/2"–4"			
	7/8" Hole Saw	2" Hole Saw	4 1/8" Hole Saw	M45P Arbor
	1 1/8" Hole Saw	2 1/2" Hole Saw	4 1/2" Hole Saw	
	1 3/8" Hole Saw	3" Hole Saw	M24K Arbor	
	1 3/4" Hole Saw	3 5/8" Hole Saw	M44 Arbor	

★ Made in USA



MAINTENANCE HOLE SAW KIT • PLUMBERS & ELECTRICIANS

- Kit contains 9 plumbing and electrical sizes.
- Includes 12" arbor extension.
- The most versatile choice for electricians and plumbers working with 1/2" to 2" pipe and conduit.

		 Kits		
Part #	Description			
86530 ★ (13 Piece Kit)	Pipe Entrance Kit For Pipe 1/2"–2"			
	3/4" Hole Saw	1 1/2" Hole Saw	2 1/2" Hole Saw	ME12 Ext
	7/8" Hole Saw	1 3/4" Hole Saw	M24K Arbor	
	1 1/8" Hole Saw	2" Hole Saw	M44 Arbor	
	1 3/8" Hole Saw	2 1/4" Hole Saw	M45P Arbor	

★ Made in USA



TOOLS

CARBIDE GRIT HOLE SAWS

- The perfect choice for installing recessed lighting. Carbide cuts through ceiling tiles without catching.
- Requires separate arbor (see below).
- Outstanding for cutting through steel, copper and aluminum.
- Gulletted edge with 1 3/8" cutting depth (86302, 86303 and 86304 do not have a gulletted edge).

Hole Diameter	For Installing These Light Fixtures	Arbor #	Part #
7/8"	—	86545 ★ or 86556 ★	86314 ★
1 1/8"	—		86322 ★
1 3/8"	—		86328 ★
1 3/4"	—		86338 ★
3 5/8"	3-0 Outlet Boxes	86545 ★ or 86556 ★	86305 ★
4 1/8"	Capri, 4-0 Outlet Boxes		86306 ★
4 3/8"	Capri, Halo, Juno, Marco		86301 ★
6 3/8"	Capri, Halo		86302 ★
6 5/8"	Juno, Progress		86303 ★
6 7/8"	Capri, Lightolier, Lithonia, Progress, Prescolite, Marco		86304 ★

★ Made in USA



Great For

- Cement Board
- Plaster • Drywall
- Stucco • Plywood
- Ceiling Tiles
- Acoustical Tiles

CARBON STEEL TAPS • PLUG STYLE



- High speed steel stays sharp even after tapping hardened alloys.
- All taps are national coarse except 10-32 National Fine.

Carbon Steel Tap			Corresponding Drill Bit		
Description	Part #	Pkg Qty	Drill Size	Part #	Qty
6-32	68037	5	#36	91736	12
8-32	68039	5	#29	91729	12
10-24	68041	5	#25	91725	12
10-32	68042	5	#21	91721	12
¼-20	68047	5	#7	91707	12
⅝-18	68049	5	"F"	9170F	12
⅜-16	68080	5	⅝"	91617	6
½-13	68084	5	⅔"	91624	12

CARBON STEEL TAP WRENCHES • PLUG STYLE



Description	Part #	Qty
Tap Handle for 6-32 to ¼-20	69902	1
Tap Handle for ¼-20 to ½-13	69904	1

CARBON STEEL TAPS & DRILL SET

- Essential kit for every electrical contractor.
- Contains the 6 most popular tap sizes with corresponding twist drills and universal T-Handle.



Part #	Description
96042 ★ (13 Piece Kit)	Tap & Drill Bit Set Carbon Plug Taps: 4-40, 6-32, 8-32, 10-24, 10-32, ¼-20 (6 Pieces) High Speed Twist Drills: #43, #36, #29, #25, #21, #7 (6 Pieces) T-Handled Wrench (1 Piece)

★ Made in USA

HEX SHANK TAPS



- Specially designed for the Quick Change Drill Adapter (page 139).
- Fits all hex shank power and hand tools.

Description	Part #	Qty
6-32 Hex Shank Power Tap	68036 ★	1
8-32 Hex Shank Power Tap	68038 ★	1
10-24 Hex Shank Power Tap	68040 ★	1
10-32 Hex Shank Power Tap	68044 ★	1
¼-20 Hex Shank Power Tap	68046 ★	1
Hex Shank Power Tap Kit (Includes 6-32, 8-32, 10-24, 10-32, ¼-20)	68096 ★	1

★ Made in USA

SCREW EXTRACTOR & DRILL BIT SET

- Removes broken screws and bolts.
- Insert into pre-drilled hole and back out with a wrench. Broken part will dislodge.

 Kits	
Part #	Description
96046 ★ (10 Piece Kit)	Screw Extractor Kit Screw Extractors: #1, #2, #3, #4, #5 (5 Pieces) Twist Drills: $\frac{5}{64}$, $\frac{7}{64}$, $\frac{5}{32}$, $\frac{1}{4}$, $\frac{17}{64}$ (5 Pieces)



★ Made in USA

DAMAGED SCREW REMOVAL SET

- For Phillips, slotted, star and square screws.
- Hardened steel bits for secure bit.
- $\frac{1}{4}$ " Hex shank fits drills, sockets and screwdrivers.
- Sizes #1, #2 and #3 screw removers in handy storage case.

Description	Part #	Qty
3 Piece Damaged Screw Removal Set	96047	1



DRYWALL JAB SAW

- Extra rigid 6" carbon steel blade.
- Sharp point for easy penetration.
- Ergonomic no slip handle.

Description	Part #	Qty
6" Drywall Jab Saw	37450	10



HACKSAW BLADES • BI-METAL CONSTRUCTION



- Cuts wood, plastic or any machinable metal, including conduit, stainless steel tubing, angle iron and copper tubing.
- Tooth hardness RC 65-67.
- Outperforms leading hacksaw brands.

Description	Teeth/Inch	Part #	Pkg
12" x 1/2" W x .025"	18	86618 ★	10
12" x 1/2" W x .025"	24	86624 ★	10
12" x 1/2" W x .025"	32	86632 ★	10

★ Made in USA

HACKSAW FRAME • LIGHT WEIGHT • HIGH TENSION



- Locking screw design with multiple pin locations and tensioning handle.
- Standard or angled blade mounting.
- Stores blade or secures blade for job sawing.

Description	Part #	Qty
High-Tension Hacksaw Frame	86640 ★	1

★ Made in USA

RECIPROCATING SAW BLADES • BI-METAL • 1/2" SHANK



Length	Teeth/Inch	Use	Application	Part #	Pkg
4	14	Metal	1/8" Thick and Above	86633 ★	5
6	14	Metal	1/8" Thick and Above	86634 ★	5
4	18	Metal	18 Gauge to 1/8"	86637 ★	5
6	18	Metal	18 Gauge to 1/8"	86638 ★	5
4	24	Metal	18 Gauge and Under	86641 ★	5
6	24	Metal	18 Gauge and Under	86644 ★	5
8	10	Wood/Metal	All Woods, Plastic, Alum	86650 ★	5
3 1/2	17	Wood/Metal	Scroll Cuts Wood, Alum	86655 ★	5
6	5-7	Wood	Plaster w/Metal Lath	86660 ★	5
12	5-7	Wood	Plasterboard	86665 ★	5
6	6	Plaster	Sheetrock	86670 ★	5

★ Made in USA

PVC CABLE SAW

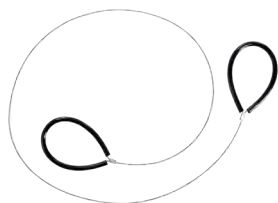

- Flexible handles allow cutting in hard to reach situations.
- Economy priced.

Description	Part #	Unit	Qty
PVC Cable Saw	96260 ★	1	24

★ Made in USA

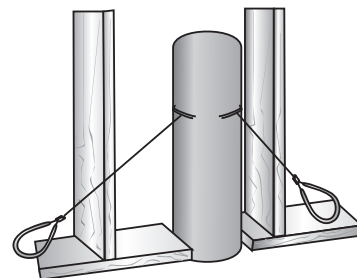

ACCUSHARP® KNIFE SHARPENER

Description	Part #	Case Qty
Accusharp® Knife Sharpener	37400 ★	12
Accusharp® Knife Sharpener Camo	37400C ★	12

Can be ordered individually.

- Fast, effective results with twin blades set at optimal 21° cutting angle.
- Form fitted handle fits either hand safely and securely.
- Safe and easy to use with durable full sized knuckle guard.
- Tungsten carbide blades. Diamond-honed and precision formed with an RC of 97.
- Great for sharpening knives, shovels, garden tools and axes.
- See page 272 for display details.



QUICKBLADE™ • ERGONOMIC UTILITY KNIFE

Description	Part #	Qty
Autoload Utility Knife	90214	1
Ergonomic Utility Knife	90215	1
Straight Edge Blades	90228 ★	5 Pk
Straight Edge Blades	90229 ★	100 Pk

★ Made in USA

- Spring loaded hinge.
- Packed with a straight blade.
- Locking knob is flush with knife handle and stays attached to knife.
- Counter display available at no additional charge with orders of 18.



TITAN™ FOLDING POCKET UTILITY KNIFE

Description	Part #	Qty
Titan™ Folding Pocket Utility Knife	37975	1

- Blade locks in open position for safety.
- Uses standard utility blades.
- Belt clip included.
- Change blade with the push of a button, no tools necessary.
- Folds compact for easy storage and portability.



BONUS!
5 FREE blades in a handy dispenser!



Folds compact for safety

URASEAL SPLICE KITS



ES137S



ES200S



Wire Type	Butt Splice Configuration			Through Splice Configuration	
	ES137S	ES200S	ES200SV	ES200SV	ES1150
	Number of Conductors (Max.)			Number of Conductors (Max.)	
18-16	Up to 10	Up to 20	Up to 14	Up to 14	—
14-12	6	12	9	9	—
10	4	8	6	6	—
8	3	6	4	4	4
6	2	2	2	2	3
4	2	2	2	2	2
3	2	2	2	2	2
2	1	2	2	2	2
1	1	2	2	2	2
1/0	—	—	—	—	2
2/0	—	—	—	—	2
3/0	—	—	—	—	2
4/0	—	—	—	—	2
250 mcm	—	—	—	—	2

★ Made in USA

ES137S ★

Smaller butt and branch splice applications.

ES200S ★

Butt and branch splice applications.

ES200SV ★

Perfect for small hard-to-reach areas. The closure snaps into place over the splice. Can be used for butt, branch or through splice applications.

ES1150 ★

For a range of cable sizes from 8-4/0 and 250 mcm single service conductors.

ABSOLUTE PROTECTION FOR ANY SPLICE IN A WET OR DAMP ENVIRONMENT

Fix any broken cable using Uruseal's Shake N' Seal splice protection system. Developed specifically for the electrical market, this new splicing system provides a permanent seal that is 100% water tight.



This proven technology has been used in similar sealing applications for over 30 years without failure!

Replaces the sheath integrity with an absolute seal around the splice or damaged cable. Add a length of wire to a run, or build a branch splice. Safe and easy to use. No need for a torch or open flame.

Easy as...

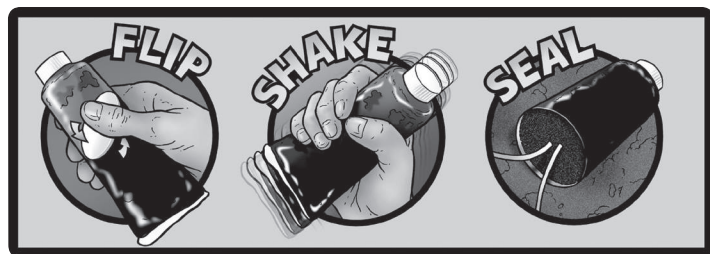

Features

- Submersible in water
- No mess
- Immediate burial
- Safe, no torch
- Permanent Seal
- Set-up less than 2 minutes!



TAPE MEASURE

- Tough, impact resistant plastic case.
- Comfortable sleeve for better grip.
- Hands-free blade lock.

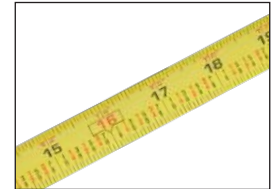

Description	Part #	Qty
Tape Measure 25" x 1"	86980	1

QUICKIE TIE-DOWN STRAPS

- Patented, self-locking rope pulley.
- The quickest, easiest tie-down on the market.
- Comes with 8 feet of high quality rope to fasten a variety of loads.
- Carries a one year warranty on manufactured parts, so you can be assured of quality.
- ¼" – 150 lb (Safe Working Load)
- ⅜" – 400 lb (Safe Working Load)



Description	Part #	Unit	Qty
¼" Quickie Tie Down Strap	37216	1	12
⅜" Quickie Tie Down Strap	37218	1	12



TARP STRAPS

Description	Part #	Qty
9" Rubber Tarp Strap	37204 ★	1
15" Rubber Tarp Strap	37205 ★	1
20" Rubber Tarp Strap	37206 ★	1
24" Rubber Tarp Strap	37207 ★	1
31" Rubber Tarp Strap	37208 ★	1
41" Rubber Tarp Strap	37209 ★	1

★ Made in USA



- Exceptional performance even under the harshest conditions.
- Features pre-inserted "S" hooks.

YELLOW POLYPROPYLENE PULL ROPE



- Safety yellow
- Light weight
- Strong
- Rot Proof
- Water, oil and gas resistant
- Available in all popular sizes
- Longer lengths available

Rope Diameter	Length (ft)	Work Load (lbs)	Break Point (lbs)	Part #
3/16	250	72	800	67800
3/16	600	72	800	67802
3/16	1000	72	800	67804
3/16	1200	72	800	67806
1/4	250	113	1250	67812
1/4	600	113	1250	67814
1/4	1000	113	1250	67816
1/4	1200	113	1250	67818
1/4	2400	113	1250	67820
1/4	4000	113	1250	67822
1/4	5000	113	1250	67824
3/8	300	243	2700	67826
3/8	600	243	2700	67828
3/8	1200	243	2700	67830
3/8	2400	243	2700	67832
3/8	3600	243	2700	67834
1/2	300	378	4200	67836
1/2	600	378	4200	67838
1/2	1200	378	4200	67840
5/8	600	558	6200	67842
5/8	1200	558	6200	67844
3/4	600	756	8500	67846
1	600	1260	14000	67848

TOOLS

POLYESTER PULLING TAPE/MULE TAPE



- Durable foot markings for accurate measurements.
- Flat construction and lubricants work to minimize friction and duct cutting.
- Soft construction for easy handling.

Width	Length (ft)	Tensile (lbs)	Part #
1/2	500	1250	67680 ★
1/2	1500	1250	67682 ★
1/2	3000	1250	67684 ★
5/8	500	1800	67686 ★
5/8	1500	1800	67688 ★
5/8	3000	1800	67690 ★
3/4	500	2500	67692 ★
3/4	1500	2500	67694 ★
3/4	3000	2500	67696 ★

★ Made in USA

POLYESTER CONDUIT MEASURING TAPE

- Durable foot markings for accurate measurements.
- Low elongation polyester.

Length (ft)	Tensile (lbs)	Part #	Unit	Case Qty
3000	140	67700 ★	1	8

★ Made in USA



POLYPROPYLENE BLOW TWINE

- Lightweight construction.
- Blows easily into conduit.

Description	Length (ft)	Tensile (lbs)	Part #	Unit
Two Ply (Pail)	6500	200	67699 ★	1

★ Made in USA



TOOLS

LINE PACKAGES

Size	Part #	Qty
½ x 75'	67710 ★	10
½ x 150'	67712 ★	10
¾ x 75'	67714 ★	10
¾ x 200'	67716 ★	5
¾ x 300'	67718 ★	5
¾ x 450'	67720 ★	5
1 x 75'	67722 ★	10
1 x 200'	67724 ★	5
1 x 300'	67726 ★	5
1 x 450'	67728 ★	5

★ Made in USA

- ½" red, ¾" yellow, 1" white.
- Line packages combine piston and string into a single package. With a portable blower you can blow or vacuum the nylon line and pull a rope through.
- Nylon Fishline features center feed for fast payout.



Nylon Fishline

Size	Strength	Part #	Qty
2150'	85# Tensile	67730 ★	1 Spool



FOAM CONDUIT PISTONS



Size	Part #	Qty
1/2	67740 ★	5
3/4	67742 ★	5
1	67744 ★	5
1 1/4	67746 ★	2
1 1/2	67748 ★	1
2	67750 ★	1
2 1/2	67752 ★	1
3	67754 ★	1
3 1/2	67756 ★	1
4	67758 ★	1
5	67760 ★	1
6	67762 ★	1

- Power fishing pistons are used with a vacuum or blower to pull line through a conduit run.
- Fits most conduits 1/2" through 6".
- Eyes or hooks at both ends.
- Tough foam piston cleans its own path and provides an air tight seal.

★ Made in USA

RECEPTACLE SHIM

- Each strip has 8 foldable (tear off) segments.
- Each segment provides 1/8" spacing.
- No need to remove screw.
- Low density polyethylene; non-conductive.

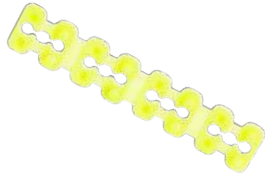

Description	Gravity Feed Jar		
	Part #	Jar Qty	Master Carton
25 Strips of 8 Shims per Jar	CPRS25J ★	25	200

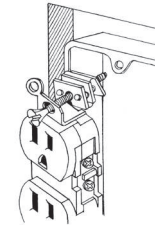

★ Made in USA

NON-METALLIC SHEATHED CABLE CONNECTORS



- Industry leading 60lb wire pull-out vs. 25lb of several competitors.
- Long body with rounded edges = easier and safer installations.
- Capacities:
RC50 One Cable: 14/2, 12/2, 10/2, 14/3, 12/3, 10/3
Two cable: 14/2, 12/2, 14/3
RC75 One Cable: 8/3 – 6/3
- CSA approved.
- VO fire rated.

RC50 Common Uses: RC75 Common Uses:

- | | |
|--|--|
| <ul style="list-style-type: none"> • Load Centers • Down Lights (i.e. Cans) • Strip Lights, Exhaust Fans • Any 1/2" K/O where non-metallic cable is allowed. | <ul style="list-style-type: none"> • Load Centers • Sub Feeds • Electric Ranges • Electric Ovens • A/C Units • Any 3/4" K/O where non-metallic cable is allowed. |
|--|--|

Description	Hang Tag Bag		5x11 Plastic Jar	
	Part #	Std Pkg	Part #	Std Pkg
1/2" Non-Metallic Sheathed Connector	RC50	100	RC50J	275
3/4" Non-Metallic Sheathed Connector	RC75	50	RC75J	165

PLASTIC STEEL STUD BUSHINGS

- Patented one piece design means no mating of pieces and only one piece to keep track of.
- Easy and quick installation and removal.
- UL and CSA approved.
- V0 fire rated.

Description	Hang Tag Bag		5x11 Plastic Jar	
	Part #	Std Pkg	Part #	Std Pkg
Round Steel Stud Bushing	RSS	100	RSSJ	200
Square Steel Stud Bushing	SSS	100	SSSJ	125



RSSJ

ANTI-SHORT BUSHINGS

- Prevents damage to wire installation.
- Constructed of thermoplastic material.

Description	Fits Cable	Part #	Jar Qty	Master Carton
Size 0 Anti-Short Bushing	14/2, 14/3, 12/2, 12/3	67420J	50	600
Size 1 Anti-Short Bushing	14/4, 6/1, 4/1	67421J	50	600
Size 2 Anti-Short Bushing	12/4, 10/2, 10/3, 2/1	67422J	50	300
Size 3 Anti-Short Bushing	10/4, 8/2, 8/3, 1/1	67423J	25	150
Size 4 Anti-Short Bushing	8/4, 6/2, 6/3, 6/4, 4/2, 4/3	67424J	25	150



TOOLS

KNOCK-OUT BUSHINGS

- Converts raw-edged holes to smooth, neat, insulated holes.
- Locking fingers snap into holes with fingertip pressure.
- Withstands a push back force of 35 lbs.
- Insulates and mechanically protects electrical and telecommunication cables, tubing, hose, rope and utility lines.

Description	Part #	Box Qty
1/2" Knock Out Bushing	95090	100
3/4" Knock Out Bushing	95092	100
1" Knock Out Bushing	95094	50
1 1/4" Knock Out Bushing	95096	25
1 1/2" Knock Out Bushing	95098	10
2" Nylon Knock Out Bushing	95100	10
2 1/2" Nylon Knock Out Bushing	95102	10



COLOR-CODED PVC ELECTRICAL TAPE • “PHASE TAPE”



- 7mil tape features excellent insulation and anti-corrosion qualities. UL-Listed.
- An economical tape that remains flexible even in extreme temperatures. Can be applied from 40°F to 176°F.
- Cellophane wrapped in sleeves of 10.

Size	Color	Part #	Unit	Sleeve Qty
¾ x 60'	Brown	94361	1 Roll	10
¾ x 60'	Red	94362	1 Roll	10
¾ x 60'	Orange	94363	1 Roll	10
¾ x 60'	Yellow	94364	1 Roll	10
¾ x 60'	Green	94365	1 Roll	10
¾ x 60'	Blue	94366	1 Roll	10
¾ x 60'	Grey	94368	1 Roll	10
¾ x 60'	White	94369	1 Roll	10

BLACK PVC ELECTRICAL TAPE • PREMIUM & ECONOMY



Size	Color	Part #	Sleeve Qty
¾ x 60'	Black Economy	94315	10
¾ x 60'	Black Premium	94317	10

- Both tapes feature UL-Listed 7 mil PVC with excellent insulation and anti-corrosion qualities.
- Premium tape offers greater adhesion and elasticity, especially in cold in weather environments.

RUBBER TAPE

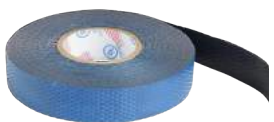

Size	Part #	Unit	Sleeve Qty
¾ x 22'	94325	1 Roll	10

- Rubber tape has low adhesive quality, designed to be used as a surface covering with friction tape or vinyl tape.
- 30mil UL-Listed tape suitable for use up to 176°F.

FRICION TAPE • CONTRACTOR GRADE



Size	Color	Part #	Unit
¾ x 60'	Black	94320	1 Roll

- Strong adhesive quality often used for wrapping low-voltage splices.

DUCT TAPE • INDUSTRIAL GRADE • CLOTH LAMINATE

- 11 mil industrial grade tape is coated with rubber base adhesive for extra adhesion.
- Economy tape is 8 mil.



Size	Description	Part #	Unit	Pkg Qty
2" x 60 Yards	Premium	94357	1 Roll	24
2" x 60 Yards	Standard	94396 ★	1 Roll	24
2" x 60 Yards	Economy	94394 ★	1 Roll	24

★ Made in USA

CARTON SEALING TAPE • GENERAL PURPOSE TAPE

- Good all-purpose tape for packaging, mailing and for quick fix solutions.
- Will fit most standard hand-held packaging tape dispensers.



Size	Description	Part #	Unit	Pkg Qty
2" x 110' Yards	Clear	94330 ★	1 Roll	6

★ Made in USA

STRAPPING TAPE • GLASS FILAMENT • NON-TEARING

Size	Part #	Unit	Pkg Qty
¾" x 60 Yards	94340 ★	1 Roll	12

Tensile Strength = 100lbs/inch

★ Made in USA

- Excellent choice for bundling lumber and pipes.
- Fits most hand-held strapping tape dispensers.
- Abrasion-resistant tape is reinforced with glass yard filaments for maximum strength.



PIPE WRAP

- Protects overhead and buried pipe joints, conduit and couplings.
- Resistant to oil, water, sun and corrosive materials.
- Universal Plumbing Code approved.

Description	Part #	Unit	Std Pack
1" x 100' 10 mil UPC Approved Pipe Wrap	94433	1 Roll	12
2" x 100' 10 mil UPC Approved Pipe Wrap	94434	1 Roll	6
4" x 100' 10 mil UPC Approved Pipe Wrap	94435	1 Roll	3
2" x 100' 20 mil UPC Approved Pipe Wrap	94436	1 Roll	6



BARRICADE & CAUTION TAPE



Size	Legend	Color	Part #	Unit	Std Pack
3" x 1000'	"Gas Line Below"	Yellow	94607	1 Roll	8
6" x 1000'	"Gas Line Below"	Yellow	94614	1 Roll	4
3" x 1000'	"Caution-Caution-Caution"	Yellow	94625	1 Roll	8
6" x 1000'	"Caution High Voltage"	Yellow	94628	1 Roll	8

Other messages available.

UNDERGROUND BURIAL TAPE • 4 MIL CONTINUOUS REPEAT WARNINGS



Size	Legend	Color	Part #	Unit	Std Pack
3" x 1000'	"Buried Electrical Line"	Red	94605	1 Roll	8
3" x 1000'	"Buried Electrical Line"	Yellow	94606	1 Roll	8
6" x 1000'	"Buried Electrical Line"	Red	94615	1 Roll	4
6" x 1000'	"Buried Electrical Line"	Yellow	94616	1 Roll	4
3" x 1000'	"Buried Telephone Line"	Orange	94617	1 Roll	8
6" x 1000'	"Buried Telephone Line"	Orange	94618	1 Roll	4

Other messages available.

UNDERGROUND DETECTABLE TAPE • 5 MIL FOIL BONDED POLYETHYLENE



Size	Legend	Color	Part #	Unit	Std Pack
3" x 1000'	"Buried Electrical Line"	Silver w/Red Stripes	94635	1 Roll	8
6" x 1000'	"Buried Electrical Line"	Silver w/Red Stripes	94636	1 Roll	4
3" x 1000'	"Buried Water Line Below"	Silver w/Blue Stripes	94638	1 Roll	8
6" x 1000'	"Buried Water Line Below"	Silver w/Blue Stripes	94639	1 Roll	4
3" x 1000'	"Buried Telephone Line Below"	Silver w/Orange Stripes	94640	1 Roll	8
6" x 1000'	"Buried Telephone Line Below"	Silver w/Orange Stripes	94641	1 Roll	4

Other messages available.



INFINITY PROTECTIVE EYEWEAR

Part #	Crossfire® Model #	Description
19100	241	Black Frame w/Smoke Lens
19101	263	Black Frame w/Silver Mirror Lens
19102	2117	Brown Frame w/HD Brown Mirror Lens
19103	2812	Black & Orange Frame w/Gold Mirror Lens

Attractive and comfortable, these glasses are appealing to the eye and face while serving as a tough optical shield of protection.



19102

- High-grade Polycarbonate construction.
- Meets and exceeds ANSI Z87+ high-impact specifications.
- Nonslip rubber temple ends.
- Lenses provide 99.9% protection from harmful UVA/UVB rays.
- Comfort fit rubber nosepiece.
- Ultralight frame design for comfortable fit.

SNIPER PROTECTIVE EYEWEAR

Part #	Crossfire® Model #	Description
19105	9117	Brown Frame w/Brown Mirror Lens
19106	9141	Brown/Camo Frame w/Smoke Lens

Designed for tactical vision, these glasses serve as a stylish option for the sniper who seeks long lasting eye protection.



19105

- TR-90 ultraflex, ultralight frame technology.
- Meets and exceeds ANSI Z87+ high-impact specifications.
- Comfort fit Rubber nosepiece.
- Lenses provide 99.9% protection from harmful UVA/UVB rays.
- Soft, nonslip Rubber temple ends.

ES4 SAFETY GLASSES

Part #	Crossfire® Model #	Description
19135	2141	Black Frame w/Smoke Lens
19136	2169	Black Frame w/HD Red Mirror Lens
19137	211125	Brown Frame w/HD Brown Mirror Lens

Crossfire® ES4 Safety Glasses are designed for all environments and features an adjustable nose piece, ultralight frame and 100% visually correct lenses.



19136

- Half frame

ES5 SAFETY GLASSES

Part #	Crossfire® Model #	Description
19125	2961	Pearl Black Frame w/Smoke Lens
19126	29117	Brown Frame w/HD Brown Mirror Lens
19127	29215	Black Frame w/Indoor/Outdoor Lens

Crossfire® ES5 Safety Glasses are designed for outdoor sports and features a polished look with a light weight fit. The sleek framework provides substantial coverage for a variety of environments.



19127

- Half frame



INFINITY POLARIZED SAFETY EYEWEAR **NEW!**



Part #	Crossfire® Model #	Description
19104	21126	Brown Frame w/Polarized Brown Lens

- Hard coat polycarbonate lens protects against scratches
- Provides 99.9% UVA and UVB protection
- Complies with ANSI Z87.1 standards
- Provides 99.9% UVA and UVB protection
- Complies with ANSI Z87.1 standards

SNIPER POLARIZED SAFETY EYEWEAR **NEW!**



Part #	Crossfire® Model #	Description
19107	9614	Black Frame w/Polarized Smoke Lens

- Vented Rubber Nosepiece for added comfort
- Lightweight, Flexible Temples for a comfortable fit
- Hard coat polycarbonate lens protects against scratches
- Provides 99.9% UVA and UVB protection
- Complies with ANSI Z87.1 standards

CORE POLARIZED SAFETY EYEWEAR **NEW!**



Part #	Crossfire® Model #	Description
19116	181813	Brown Frame w/HD Polarized Brown Lens

- Rubber Nosepiece for all day comfort
- Rubber Insert, Sport Temple Grips for a snug fit

RPG POLARIZED EYEWEAR **NEW!**



Part #	Crossfire® Model #	Description
19121	23226	Black Frame w/Polarized HD Blue Mirror Lens

- Full Frame



ES5 POLARIZED SAFETY EYEWEAR *NEW!*

Part #	Crossfire® Model #	Description
19128	291113	Brown Frame w/Polarized HD Brown Lens

- Vented Rubber Nosepiece for breathability
- Dual Mold, Rubber Temple Grips for better stability
- Hard coat polycarbonate lens protects against scratches
- Provides 99.9% UVA and UVB protection
- Complies with ANSI Z87.1 standards



MP7 POLARIZED SAFETY EYEWEAR *NEW!*

Part #	Crossfire® Model #	Description
19134	24426	Black Frame w/Blue/Green Lens

- Full-Frame Design for maximum protection
- Dual Mold, Rubber Temple Grips for better stability
- Hard coat polycarbonate lens protects against scratches
- Provides 99.9% UVA and UVB protection
- Complies with ANSI Z87.1 standards



ES4 POLARIZED SAFETY EYEWEAR *NEW!*

Part #	Crossfire® Model #	Description
19138	21427	Black Frame w/HD Polarized Silver Mirror Lens

- Adjustable Rubber Nosepiece for added comfort
- Dual Mold, Rubber Temple Grips for better stability
- Hard coat polycarbonate lens protects against scratches
- Provides 99.9% UVA and UVB protection
- Complies with ANSI Z87.1 standards



SAFETY



COBRA PROTECTIVE EYEWEAR



Protect your eyes while on patrol in Crossfire® Cobra Protective Eyewear. Exceeding high-impact standards, these glasses boast tough durability and comfort for the law professional on-the-go.

Part #	Crossfire® Model #	Description
19110	1541	Black Frame w/Smoke Lens

- High-grade Polycarbonate construction.
- Meets and exceeds ANSI Z87+ high-impact specifications.
- Lenses provide 99.9% protection from harmful UVA/UVB rays.
- Comfort fit rubber nosepiece.
- Soft, nonslip rubber temple ends.
- Ultralight frame design for comfortable fit.

CORE PROTECTIVE EYEWEAR



Designed with the law professional in mind, these glasses are extremely durable and lightweight.

Part #	Crossfire® Model #	Description
19115	18146	Woodland Brown/Camo Frame w/ HD Brown Mirror Lens

- Meets and exceeds ANSI Z87.1-2003 high impact standards.
- 99.9% protection from harmful UVA and UVB rays.
- 100% visually correct decentered lenses.
- Rubber nose pads.
- Temple grips.

KP6 SAFETY SUNGLASSES



Crossfire® KP6 Safety Sunglasses are stylish enough to wear on or off the job.

Part #	Crossfire® Model #	Description
19130	3441	Black Frame w/Smoke Lens
19131	3469	Black Frame w/Red Mirror Lens
19132	34257	Brown Frame w/Brown Mirror Lens

- Polycarbonate ¾-frame

RPG SAFETY SUNGLASSES



The redesigned full frame Crossfire® RPG Safety Glasses make the list once again as one of Crossfire's best selling styles. Fitting a wide range of users, it is offered in various lens selections for application in diverse environments.

Part #	Crossfire® Model #	Description
19120	23233	Black/Red Frame w/Silver Mirror Lens

- Full frame

Nemesis™

Part #	Description
19804	Black Frame w/Clear Lens
19805	Black Frame w/Clear FogGard™ Lens
19806	Black Frame w/Smoke Mirror Lens
19807	Black Frame w/Indoor/Outdoor Lens
19808	Black Frame w/Blue Mirror Lens
19809	Black Frame w/Amber Lens
19810	Blue Frame w/Light Blue Lens
19811	Camo Frame w/Bronze Lens
19812	Camo Frame w/Clear Anti-Fog Lens
19814	Camo Frame w/Amber Anti-Fog Lens

Sleek, sporty style!

Nemesis safety glasses meet ANSI Z87.1+ impact standards and provide 99.9% protection from harmful UV rays.

FogGard® Plus is a permanent lens coating proven to eliminate lens fogging in 99% of workplace applications.



Nemesis-VI™

Part #	Description
19840	Metal Frame w/Clear Lens
19843	Metal Frame w/Indoor/Outdoor Lens
19844	Metal Frame w/Blue Mirror Lens
19880	Camo Frame w/Copper Lens

- Frameless ultra-lightweight design, 33% lighter weight than Nemesis.
- No-brow design increases upward and peripheral vision.

- Slip-stop temples designed to prevent slipping and sliding when hot.



Nemesis Rx™

Part #	Description
19831	Black Frame w/Clear Readers (1.5)
19832	Black Frame w/Clear Readers (2.0)

- “Cheaters” style with integral adopters for vision assistance.
- Larger lens for more complete wrap around protection.
- Precise placement of inserts allows for distortion-free forward vision and increased safety when wearing.

- Enhanced nose piece design with integrated ridges to channel away sweat.
- Meets CSA.





Smith & Wesson®



Part #	Description
19850	Metal Frame w/Smoke Anti-Fog Lens
19852	Blue Frame w/Blue Mirror Lens

- Soft rubber nose pads for superior comfort and fit.
- Sport grip temples eliminates slippage.
- Wrap-around protection.
- Lens options include anti-scratch or anti-fog coating.
- Complete with micro-fiber carry pouch that doubles as a cleaning cloth.



Part #	Description
19860	Black Frame w/Smoke Mirror Lens
19862	Black Frame w/Blue Mirror Lens

- Steamlined, sunglas styling.
- High performance polycarbonate lens.
- Extreme lightweight design.
- Flex point temples for comfort and stability.

OTG – OVER THE GLASSES



Part #	Description
19870	Black Frame w/Clear FogGuard™ Lens
19872	Black Frame w/Smoke Mirror FogGuard™ Lens
19874	Black Frame w/Indoor/Outdoor

- Side shields provide added protection.
- Comfortable fit for extended wear.
- Fits over most prescription glasses.

DISPOSABLE DUST MASKS • GENERAL PURPOSE

Deluxe N95 Respirator

- Meets NIOSH 42 CFR 84 standards at 95% efficiency.
- Valve reduces hot air build up.
- Collapse resistant shell last longer.

Standard Disposable Respirator

- 100% PVC-Free. Dura-Mesh® shell resists collapsing in heat and humidity.
- Molded nose bridge seals easily without a metal noseband.
- Meets heat and flame resistant in accordance with ANSI/ISEA 110-2003 Section 7.11.1



Size	Application Environment	Part #	Pkg Qty
Economy N95 Respirator with Adjustable Metal Nose Piece	Dusty	19602	5
Respirator with Exhale Valve	Hot, Humid, Dusty	19604	10
Respirator with Molded Nose Bridge	Hot, Humid, Dusty	19608	50

“SPARK PLUGS” HEARING PROTECTION • LOW PRESSURE FOAM

- Extra soft, low pressure foam for extra comfort.
- Noise reduction rating (NRR): 31.
- **OSHA Approval Rules:** OSHA approves hearing protection only in accordance with the noise level where it is used.

Description	Part #	Unit Pair/Bag	Box Qty
Uncorded “Spark Plugs”	19610	1	200
Corded “Spark Plugs”	19612	1	100

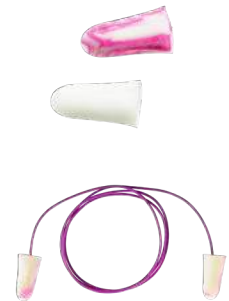

SAFETY

SAFETY VESTS

Description	Part #
Orange Reflective Safety Vest	32065
Dayglow Orange Safety Vest	32066
Class 2 Vest, Small–Medium	32067
Class 2 Vest, Large–XL	32068

- Conforms to MUTCD
- Bound in black cotton binding with elastic side straps and hook and loop front closure.



CHARGER™ HARD HAT • OSHA COMPLIANT HARD HATS



Description	Part #	Unit
White	29430 ★	1
Yellow	29432 ★	1
Blue	29434 ★	1
Green	29436 ★	1
Red	29438 ★	1
Gray	29440 ★	1
Orange	29442 ★	1
Hi Viz Orange	29444 ★	1

★ Made in USA

- Meets ANSI Z89.1 for impact protection.
- Contoured dome for sleek profile.
- Short cap bill for greater upward vision.
- Antiglare Griptech™ bill limits glare and improves bill grip.
- Constructed for the addition of a 4-point chin strap.
- Lightweight design.

SAFETY

HARD HAT LINERS



Description	Part #	Unit
Full Hard Hat Liner	22329	1
Hard Hat Liner w/Wrap Around Collar	22337	1

- Attaches securely to most popular hard hats.
- Constructed with durable, flame resistant Proban and Nomex.

25 PERSON FIRST AID KIT • MEETS OSHA AND ANSI STANDARDS

- ANSZIZ308.1-2015, OSHA: OSHA 1910.151(B), and Class A-Series 25.
- 25 person kit features exclusive compartmental design that holds packets firmly in place.
- Customized to meet the needs of electrical contractor.
- All the benefits of a wall mounted system in a portable box.



Description	Part #	Unit
25 Person Kit	23300	1



SAFETY

10 PERSON FIRST AID KIT • MEETS OSHA AND ANSI STANDARDS

- ANSZIZ308.1-2015, OSHA: OSHA 1910.151(B), and Class A-Series 25.
- Compact kit is great for service trucks.

Description	Part #	Unit
10 Person Kit	23298	1





Split Leather Work Glove

Select shoulder split leather. Wing thumb. Rubberized safety cuff.

Size	Part #
L	67600
XL	67601



Unlined Deerskin Drivers Glove

Super soft grain deerskin. Shirred elastic wrist, keystone thumb.

Size	Part #
M	67630
L	67632
XL	67634



Split Leather Drivers Glove

Russet split leather, shirred elastic wrist, keystone thumb.

Size	Part #
M	67609
L	67611
XL	67612



Unlined Grain Pigskin Drivers Glove

Grain pigskin with split pigskin back. Shirred elastic wrist, keystone thumb.

Size	Part #
M	67613
L	67618
XL	67622



Grain Leather Drivers Glove

Top grade grain cowhide leather. Shirred elastic wrist, keystone thumb.

Size	Part #
M	67636
L	67638
XL	67640



1927® Cold Weather Grain Pigskin Glove

Grain pigskin palm, wing thumb, safety cuff. Heatkeep® thermal lining. The same lining used in ski and snowmobile gloves. Pigskin dries soft after getting wet.

Size	Part #
M	67602
L	67604
XL	67608



Lined Brown Jersey Glove

9 oz. brown cotton jersey. Red fleece lining, straight thumb, shirred elastic back.

Size	Part #
L	67648



Unlined Brown Jersey Glove

8 oz. brown cotton jersey. Unlined, knit wrist, straight thumb.

Size	Part #
L	67642



Latex Coated Knit Glove

Gray knitted shell with super gripping blue latex coating.

Size	Part #
M	67650
L	67652
XL	67654

Warm Grip Latex Work Glove

Natural rubber coating for optimal abrasion resistance. Black Mesh. Gray. Form fitted for ergonomic comfort.



Size	Part #
M	67671
L	67672

White String Knit Glove

Medium weight polyester/cotton knit with elasticized wrist.



Size	Part #
L	67658

White Canvas Glove

8 oz. white canvas. Knit wrist for snug fit.



Size	Part #
L	67661

PVC Dipped Glove

Black PVC over cotton lining. Suggested for most oils, acids, caustics, alcohols and solvents. Use with care. 12" long.



Size	Part #
L	67662

Frostbreaker® Thermal Latex Gripping Glove

Black acrylic knit shell, knit wrist, dipped gray color latex palm and fingers.



Size	Part #
M	67663
L	67664
XL	67665

Nitrile Palm Coated Glove

Navy blue nylon knit shell, gray color smooth finish nitrile coated palm and fingers.



Size	Part #
S	67509
M	67510
L	67511
XL	67512

Kevlar® Lined Glove

Kevlar® lined, cut-resistant, durable, non-slip reinforcement palm. Black Mesh. Gray.



Size	Part #
M	67624
L	67625
XL	67626

See page 365 for our
Glove Display offers!



Pro-Grip Full Finger Glove

PVC Reinforced palm, thick stretch nylon between fingers. Full finger for extra protection. Black.

Size	Part #
M	67561
L	67563
XL	67565



Pro-Grip Half Finger Glove

PVC reinforced palm, thick stretch nylon between fingers. Gray Mesh. Half fingered for extra dexterity. Black.

Size	Part #
M	67551
L	67553
XL	67555



Pro-Grip Winter Plus Glove

100% waterproof and windproof. Triple layer insulating system. Keeps hands warm and dry. Black.

Size	Part #
M	67579
L	67581
XL	67583
XXL	67584
M	67579CAMO
L	67581CAMO
XL	67583CAMO



Pro-Grip Mechanic's Plus Glove

Water and oil resistant synthetic suede palm. Incredible dexterity. Internal knuckle protection. Terry cloth brow wipe on thumb. Blue.

Size	Part #
M	67567
L	67569
XL	67571



Pro-Grip Mesh General Utility Glove

Designed for warm temperatures. Breathable gray mesh. Non-slip reinforced palm, finger and thumb. Black.

Size	Part #
M	67573
L	67575
XL	67577

ROOF JACKS (FLASHINGS)

Description	Part #	Unit	Std Pack
1/2" Standard Roof Jacks	95000	1	12
3/4" Standard Roof Jacks	95002	1	12
1" Standard Roof Jacks	95004	1	12
1 1/4" Standard Roof Jacks	95006	1	24
1 1/2" Standard Roof Jacks	95008	1	24
2" Standard Roof Jacks	95010	1	24
3" Standard Roof Jacks Bath Vent	95012	1	12
4" Standard Roof Jacks Bath Vent	95014	1	12
Multi-size Galvanized Steel Base 3in1 Roof Jack 1/2, 3/4, 1	95031	1	12
Multi-size Galvanized Steel Base 3in1 Roof Jack 1-1/4 -- 3	95032	1	12
Multi-size Galvanized Steel Base Roof Jack Flashing 2in	95033	1	12
Multi-size Galvanized Steel Base Roof Jack Flashing 3in	95034	1	12
Multi-size Galvanized Steel Base Roof Jack Flashing 4in	95035	1	12

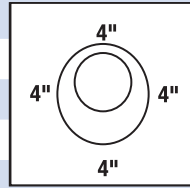

Save 10% for ordering standard pack.

SERVICE ENTRANCE CAPS

Description	Part #	Std Pack
1/2" Service Entrance Cap	95120	10
3/4" Service Entrance Cap	95122	5
1" Service Entrance Cap	95124	5
1 1/4" Service Entrance Cap	95126	5
1 1/2" Service Entrance Cap	95128	5
2" Service Entrance Cap	95130	1
2 1/2" Service Entrance Cap	95132	1
3" Service Entrance Cap	95134	1
3 1/2" Service Entrance Cap	95136	1
4" Service Entrance Cap	95138	1



- Clamp-on
- Aluminum
- For Rigid, IMC, and EMT

MISCELLANEOUS

PRE-KUTS PLASTIC SLEEPERS

Description	Part #	Pkg Qty
Pre-Kuts	96160 ★	10

★ Made in USA

- Plastic Pre-Kuts will outlast any wood or foam sleeper.
- Lightweight, easier to haul than wood sleepers.
- No special clamps needed.
- Most economical solution for this application.
- 4 1/4" x 9" x 1 1/2"



See pages 191-195 for One Hole Straps.

CABLE TIES



- Tensile strength exceeds industry standards to give you the holding power you need.
- Black cable ties are UV rated.

Length	Color	Tensile Strength (lbs)	Min/Max Bundle Diameter	Part #	Bag Qty
4	Natural	18	1/16-1/8	22200 ★	100
4	Black	18	1/16-1/8	22202 ★	100
5	Natural	40	1/16-1 1/16	22204 ★	100
5	Black	40	1/16-1 1/16	22206 ★	100
7	Natural	50	1/16-1 7/8	22208 ★	100
7	Black	50	1/16-1 7/8	22210 ★	100
8	Natural	40	1/16-2 3/8	22212 ★	100
8	Black	40	1/16-2 3/8	22214 ★	100
11	Natural	50	1/16-3 1/16	22216 ★	100
11	Black	50	1/16-3 1/16	22218 ★	100
14	Natural	50	1/16-4 1/8	22220 ★	100
14	Black	50	1/16-4 1/8	22222 ★	100
14	Natural	120	3/16-4 1/16	22224 ★	100
14	Black	120	3/16-4 1/16	22226 ★	100
36	Natural	175	3/16-11	22228 ★	50
36	Black	175	3/16-11	22230 ★	50

★ Made in USA

MOUNTING BASES • ADHESIVE-BACKED/PUNCH-OUT SCREW HOLE



- Four-sided design, adhesive backing and punch-through screw hole provide virtually unlimited options for attaching and holding.
- Black mounting bases are UV rated.

Length	Color	Part #	Bag Qty
3/4	Natural	22280 ★	100
3/4	Black	22282 ★	100
1	Natural	22284 ★	100
1	Black	22286 ★	100

★ Made in USA

MOUNTING TIES

Length	Color	Tensile Strength (lbs)	Min/Max Bundle Diameter	Part #	Bag Qty
7	Natural	50	1/16-1 3/4	22240 ★	100
7	Black	50	1/16-1 3/4	22244 ★	100
11	Natural	50	1/16-3 1/16	22254 ★	100
11	Black	50	1/16-3 1/16	22256 ★	100
14	Natural	50	1/16-4	22258 ★	100
14	Black	50	1/16-4	22260 ★	100
14	Natural	120	3/16-4	22262 ★	100
14	Black	120	3/16-4	22264 ★	100

★ Made in USA



- Screws into wood or metal for simple, secure cable bundling.
- Black mounting ties are UV rated.

CABLE TENSIONING TOOL & CABLE TIE KITS

Description	Part #
Cable Tie Tensioning Tool	22298 ★

- Black cable ties are UV rated.

Kits			
Part #	Description		
22290 ★ (400 Piece Kit)	Natural		
	4"-18lb (200 Pieces)	7"-50lb (100 Pieces)	11"-50lb (100 Pieces)
22292 ★ (400 Piece Kit)	Black		
	4"-18lb (200 Pieces)	7"-50lb (100 Pieces)	11"-50lb (100 Pieces)
22294 ★ (401 Piece Kit)	Natural		
	4"-18lb (200 Pieces)	7"-50lb (100 Pieces)	11"-50lb (100 Pieces)
22296 ★ (401 Piece Kit)	Black		
	4"-18lb (200 Pieces)	7"-50lb (100 Pieces)	11"-50lb (100 Pieces)
	Includes Tensioning Tool Part # 22298		

★ Made in USA



MISCELLANEOUS

WALL PLATE INSULATING GASKETS • FOAM THERMAL BARRIER



Description	Part #	Box Qty
Insulating Gasket	80014 ★	100

★ Made in USA

Installation: Insert one foam gasket in each outlet or switch box on perimeter walls.

- Universal design fits all standard and decora-style toggle/duplex receptacles.
- Excellent thermal barrier prevents heat loss and reduces drafts through outlets and switches.
- Foam is rated #94HF1.

REDUCING WASHERS • ZINC PLATED





	 Cardboard Box	
Size	Part #	Qty
3/4 x 1/2	33400	100
1 x 1/2	33402	100
1 x 3/4	33404	100
1 1/4 x 1/2	33406	50
1 1/4 x 3/4	33408	50
1 1/4 x 1	33410	50
1 1/2 x 1/2	33412	50
1 1/2 x 3/4	33414	50
1 1/2 x 1	33416	50
1 1/2 x 1 1/4	33418	50
2 x 1/2	33420	25
2 x 3/4	33422	25
2 x 1	33424	25
2 x 1 1/4	33426	25
2 x 1 1/2	33428	25

	 Cardboard Box	
Size	Part #	Qty
2 1/2 x 1	33430	25
2 1/2 x 1 1/4	33432	25
2 1/2 x 1 1/2	33434	25
2 1/2 x 2	33436	25
3 x 1	33438	10
3 x 1 1/4	33439	10
3 x 1 1/2	33440	10
3 x 2	33441	10
3 x 2 1/2	33443	10
3 1/2 x 1 1/2	33442	10
3 1/2 x 2	33444	10
3 1/2 x 2 1/2	33446	10
3 1/2 x 3	33448	10
4 x 2	33450	10
4 x 2 1/2	33452	10
4 x 3	33454	10
4 x 3 1/2	33456	10

REDUCING BUSHINGS • ZINC PLATED



	 Cardboard Box	
Size	Part #	Qty
1/2 x 3/8	67450	100
3/4 x 1/2	67452	100
1 x 1/2	67454	50
1 x 3/4	67456	50
1 1/4 x 1/2	67458	25
1 1/4 x 3/4	67460	25
1 1/4 x 1	67462	25
1 1/2 x 1/2	67464	25
1 1/2 x 3/4	67466	25
1 1/2 x 1	67468	25
1 1/2 x 1 1/4	67470	25
2 x 1/2	67472	10

	 Cardboard Box	
Size	Part #	Qty
2 x 3/4	67474	10
2 x 1	67476	10
2 x 1 1/4	67478	10
2 x 1 1/2	67480	10
2 x 2 1/2	67482	1
3 x 2	67484	1
3 x 2 1/2	67486	1
3 1/2 x 2	67488	1
3 1/2 x 2 1/2	67490	1
3 1/2 x 3	67492	1
4 x 2	67494	1
4 x 2 1/2	67496	1
4 x 3	67498	1
4 x 3 1/2	67499	1

SNAP-IN KNOCK-OUT SEALS • ZINC-PLATED

- Snap-in design for quick and easy installation.

Size	Part #	Box Qty	Size	Part #	Box Qty
1/2	90020	100	1 1/4	90032	50
3/4	90024	100	1 1/2	90036	50
1	90028	100	2	90040	25



3-PIECE KNOCK-OUT SEALS • ZINC-PLATED/GALVANIZED

- Size is stamped on seal.

Size	Part #	Box Qty	Size	Part #	Box Qty
1/2	90050*	100	3	90064*	10
3/4	90052*	50	3 1/2	90066	10
1	90054*	25	4	90068	10
1 1/4	90056*	25	5	90072	10
1 1/2	90058*	10	6	90074	10
2	90060*	10			
2 1/2	90062*	10			

*Comes assembled.



CEILING COVER PLATE • ADJUSTABLE

Description	Part #	Std Pkg
5 1/4" White Canopy	90010	1/25

- Includes canopy, adjustable strap and machine screws.
- White metal plate adjusts to fit 3" and 4" outlet boxes.
- Useful for temporary and permanent applications.



NON-METALLIC KNOCK-OUT SEALS

- Easy Snap in installation – No Conductivity possible.
- Tight tolerances = snug fit in different panels/boxes.
- Fits all metallic and non-metallic material from 1/32" to 1/8".
- Easy installation in tight space areas.
- UL and CSA approved.
- VO fire rated.

Description	Hang Tag Bag	
	Part #	Std Pkg
1/2" Knock Out Non-Metallic	K050	50
3/4" Knock Out Non-Metallic	K075	50
1" Knock Out Non-Metallic	K0100	25
1 1/4" Knock Out Non-Metallic	K0125	25
1 1/2" Knock Out Non-Metallic	K0150	25
2" Knock Out Non-Metallic	K0200	25



WIRE & CABLE MARKER BOOKS



Cully Wire and Cable Marker Books are manufactured with high quality vinyl cloth, but are finished with an economical flat stitch for users who don't require removable pages. The book system is convenient and fits into your pocket for travel to the job.

They are mounted on 90# super release lay flat liner. The slick surface protects the adhesive until used. This assures full bonding power when applied to a wire.

Each book contains 450 wire markers and 450 matching terminal strips. Wire and cable markers are printed on impregnated cloth, the proven general purpose material for maintenance, construction and product identification.



Hang Tag Bag

Markers	Legend	Part #	Qty
Wire & Cable	0 (45 each) 1-45 (10 each)	CULWM045 ★	1
Wire & Cable	0-9 (45 each)	CULWM09 ★	1
Wire & Cable	0-9 (45 each) L1, L2, L3, T1, T2, T3 (15 each)	CULWM09LT ★	1
Wire & Cable	1-30 (15 each)	CULWM130 ★	1
Wire & Cable	1-90 (5 each)	CULWM190 ★	1
Wire & Cable	-, /, +, A-Z (2 each) 0-15 (6 each) 16-90 (4 each)	CULWM190AZ ★	1
Wire & Cable	46-90 (10 each)	CULWM4690 ★	1
Wire & Cable	A, B, C (150 each)	CULWMABC ★	1
Wire & Cable	- (7 each) + (8 each) A-Z (15 each) BLANK (21 each)	CULWMAZ ★	1
Wire & Cable	-, /, +, 0-15, A-Z (10 each)	CULWMAZ015 ★	1
Wire & Cable	1, 2, 3, A, B, C (45 each) L1, L2, L3, T1, T2, T3 (30 each)	CULWMINST ★	1
Wire & Cable	L1, L2, L3 (150 each)	CULWML1 ★	1
Wire & Cable	T1, T2, T3 (150 each)	CULWMT1 ★	1

★ Made in USA

Continued on next page.

WIRE & CABLE MARKER BOOKS (CONT.)

		 Hang Tag Bag	
Markers	Legend	Part #	Qty
Wire & Cable	10 NEMA Colors (45 each)	CULWMNEMA ★	1
Wire & Cable	BLANK, NEUT, SPARE (21 each) GND, NEG, POS (33 each) -, +, AC, DC (45 each)	CULWMVOLT ★	1
Burglar/Security	1-30 (3 each) 1-45 (1 each) AC AC/AC AC (6 each) Annunciator, BA/BA, Feed/Feed, Fire/Fire, Ground, Phone Feed, Phone Return, Return/Return, Siren/Bell, Smoke Detector, Temperir Tamper, Thermostat (9 each) +Circuit+, -Circuit- (12 each) GB/GB, Keypads, PIR/PIR (15 each) AC Transformer (27 each) Blank (45 each) Zone/Zone (60 each)	CULWMBA ★	1
Fire/Security	1-15, 16-30 (3 each) 1-45 (1 each) AC AC/AC AC (6 each) Annunciator, Siren/Bell, Tamper (9 each) +Circuit+, -Circuit- (12 each) GB/GB, Keypads, PIR/PIR (15 each) Duct Detector, Heat Detector, Horn/Horn, Horn/Strobe, Smoke Detector, Strobe/Strobe (18 each) BLANK (45 each) Zone/Zone (60 each)	CULWMFA ★	1

★ Made in USA

MISCELLANEOUS

Minerallac[®]
Traditional

Minerallac[®]
STAINLESS STEEL

Minerallac[®]
Strut Fittings

Black Claw[™]

IMPACT[®]
STAPLES

REDMORE[®]

PICTORIAL INDEX

LOAD RATING

Minerallac fasteners are designed with two load limits:

Static Load Limit is a rated stationary load limit. The listed static load limit has a safety factor of three.

Ultimate Static Load Limit is the rated stationary load limit which, if exceeded, may cause failure of the fastener.

Load limits are for loads applied VERTICALLY except as may be diagrammed otherwise. The load capacity of a fastener having more than one component is equal to the load capacity of the lowest rated component.

MATERIALS

Steel

We specify commercial quality (CQ) hot rolled pickled and oil (HRPO) or cold rolled (CR) steel for our parts where a specific material specification is not needed.

Spring Steel

We specify a high carbon, cold rolled, annealed, spring steel for all Black Claw™ products.

Aluminum

We specify 3003-H14 on all aluminum products unless otherwise specified.

Brass

We specify a 70/30 brass C260 1/4 hard material for all our stock products. Formerly named as Everdur® in past catalogs.

COATINGS

Pre-Galvanized Zinc

This coating of zinc is applied directly at the mills by rolling the material through molten zinc. Parts fabricated from this material have exposed edges where the material has been cut; but the zinc near the uncoated metal becomes a sacrificial anode to protect the bare areas for a short period of time. These parts are recommended for indoor use in dry areas.

Zinc Plated or Electro-Galvanized

We have our parts plated after fabrication to commercial quality standards, and recommend them for indoor, relatively dry environments. Zinc plating is the process by which a coating of zinc is deposited on the steel by electrolysis from a bath of zinc salts. The zinc coating thickness for commercial quality is approximately 0.00015–0.00020 inches.

Hot Dipped Galvanized

We submerge our parts after fabrication into a molten bath of zinc thus coating all the edges of the parts. Hot Dipped Galvanized to ASTM A123 specifications. Parts are recommended for indoor/outdoor use and mildly corrosive environments.

Zinc Phosphate and Oil

We have most of our high carbon spring steel parts (Black Claw™) coated with this process after fabrication and heat-treating. The process applies a base of crystalline zinc phosphate of 1000 milligrams a square foot and then a synthetic organic corrosion inhibitor with a particular affinity for zinc compounds. These parts are recommended for indoor, non-corrosive environments.

Copper Plated

We specify a commercial grade finish on all stock copper plated parts.

WARRANTY

Minerallac warrants all products sold to be free and clear of all liens and encumbrances and to be free from defects in material and workmanship. In the event that any product fails to conform to such warranty, Minerallac's liability is limited solely to replacing such product without charge.

The warranties set forth above are exclusive and are in lieu of all other warranties whether statutory, expressed, or implied including warranties of merchantability and fitness for a

particular purpose, and warranties arising from course of dealing or usage of trade. The above provides remedy of replacement will be the sole and exclusive remedy of any purchaser of a product for any failure by Minerallac to comply with the warranty provision, whether claims by purchaser are based on contract or in tort including negligence, and in no event shall Minerallac be liable for loss of profits, indirect, special, consequential and other similar damages, and any economic loss resulting from any such failures.

Contact Customer Service for Minerallac Terms and Conditions of Sale, return policy and freight allowance.

CONDUIT/CABLE/WIRE



Conduit Hangers
pages 189–190



One-Hole Straps • Jiffy Clip®
pages 191–194



One-Hole Duplex • Jiffy Clip®
page 195



Slotted Duplex • Jiffy Clip®
page 195



Conduit Strap • Two-Hole Metal
pages 196–197



Multi-Use Two-Hole Plastic Straps
page 197



Multi-Purpose Closed Clip
page 197



Service Entrance Straps • One-Hole
page 198



Service Entrance Straps • Two-Hole
page 199

NAIL STRAPS



Nail Straps
page 200



Round Nail Straps
page 201

BEAMS



Beam Clamps • Universal
page 202



Beam Clamps • Malleable
page 202



Beam Clamp Assemblies
page 203

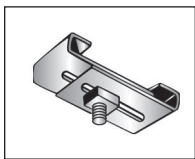

Flange/T-Bar Clip
page 203

METAL STUD & DRYWALL

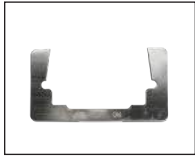

Outlet Retainer
page 204

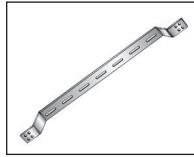

Box Mounting Bracket
page 204

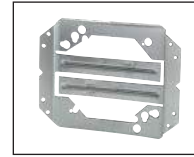

Box Stabilizer Support
page 205



Box Supports • Screwless Design
page 205



Plastic Far Side Box Support
page 206

ACOUSTICAL



T-Bar Hanger
page 207

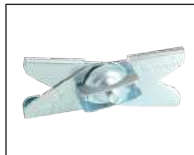

T-Bar Scissor Clips
page 207



T-Bar Drop Wire Clip
page 207

VOICE/DATA & LOW VOLTAGE



Cable Support • J Hooks
page 208



Cable Support • Bridle Rings
pages 209–210



Universal Metal Stud Grommet
page 210



Cable Protection • Nail Plates
page 211



Cable Support • D-Rings
page 212



Low Voltage Mounting Bracket
page 212

HARDWARE/ACCESSORIES



Stove Bolt with Nut
page 213



Wing Nut Washer
page 213



Perforated Strapping
page 214



Stud Clip Adapter
page 214



Brackets
page 215



Bar Joist Washers
page 215

STAINLESS STEEL HARDWARE



Conduit Hangers, Type 304
page 217



Conduit Straps, Type 304
page 218



Bean Clamps, Type 304, 316
page 219



Strut Accessories, Type 304, 316
pages 220–223



Hex Nuts, Type 18-8, 316
pages 224–225



Washers, Type 18-8, 316
pages 226–229

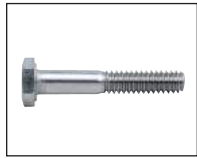

Hex Head Cap Screws, Type 18-8, 316
pages 230–233



Hex Head Tap Bolts, Type 18-8, 316
pages 234–237

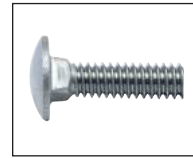

Bolts, Type 18-8
page 238



Anchors, Type 304, 316
pages 239–241



Machine Screws, Type 18-8, 316
pages 242–246



Tamperproof Machine Screws
pages 247–248

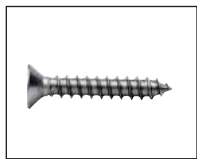

Sheet Metal Screws, Type 18-8
pages 249–252



Tamperproof Sheet Metal Screws
pages 253–254

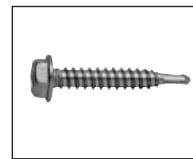

Tek Screws, Type 410
page 255



Threaded Rod, Type 18-8
page 256



Hex Coupling, Type 18-8
page 256

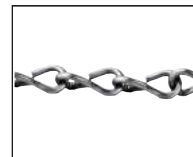

Fixture Hanging Hardware, Type 304
pages 257–258



Tools
page 258

PICTORIAL INDEX

STRUT FITTINGS ACCESSORIES



Channel Nuts
page 260-261

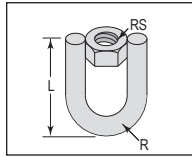

Swivels
page 262



Strut Clamps
page 263-268



Flat Fittings
page 269-272



Angle Fittings
page 273-280

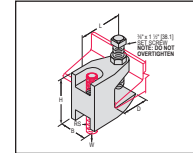

Beam Clamps
page 281-287

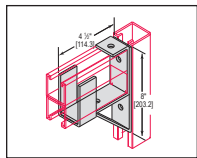

Brackets
page 288-293

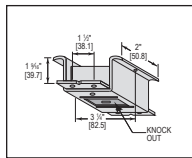

Concrete Inserts
pages 293

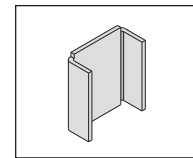

End Caps
page 294

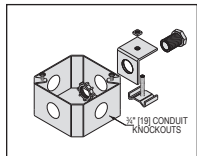

Electrical
page 295-297

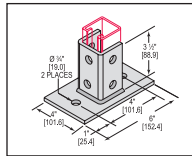

Post Bases
page 298-300

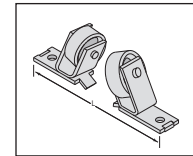

Rollers
pages 301-302

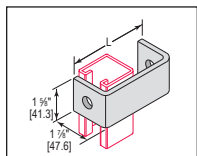

U-Fittings
page 303-306

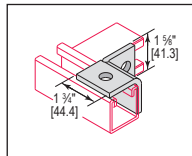

Wing Fittings
page 306-309

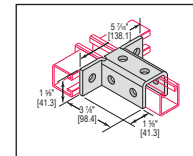

Z-Fittings
pages 310-312

CONDUIT CABLE



Conduit Clip
page 314

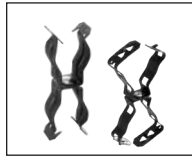

Conduit to Conduit Trapeze Assembly
page 315



Cable Clip
page 316



Conduit Clip
page 316

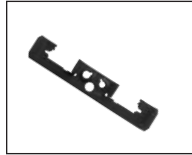

Multi-Function Clip
page 317



Multi-Function Clip Assemblies
page 317

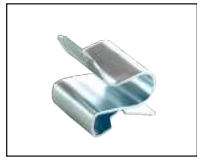

Flexible Conduit/Cable Clip
page 318



Flange Mount Conduit Clip Assembly
pages 319–320



Conduit & Box Support Fastener
pages 321–322

HANGERS



Rod/Wire • Bracket Support
page 323



Rod/Wire Beam Assemblies
page 324



Threaded Rod to Beam Assemblies
page 324



Strap Hangers
page 325



Rod Hangers
page 325

BEAM/PURLIN



Beam Clamps
pages 326–327



Flange Beam Clamp
page 328



Z Purlin Hanger
page 328



Z Purlin Hanger Assemblies
pages 329–330



Z Purlin Flange Hanger
page 330



Flange Hanger
page 331



Rod to Flange Hanger
page 331

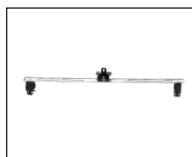

Beam Mount Conduit & Box Support Assemblies
page 332

METAL STUD



Conduit/Cable Support
page 333



Flexible Conduit/Cable Fastener
page 333

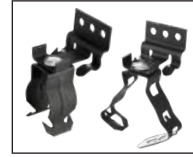

Conduit to Stud Support
page 334



Box To Stud Fastener
page 334



Box To Stud Support
page 335



Conduit to Stud Fastener
page 336



Far Side Box Support
page 336



Box Mounting Bracket
page 337



Box to T-Bar Fastener
page 337



Lighting Support Assembly
page 337

ACOUSTICAL



Lighting • Troffer Fastener
page 338



Twist on T-Bar Hanger
page 338



T-Bar Fasteners
pages 339–341

HARDWARE/ACCESSORIES



Box To Bar Fastener
page 342

NON-INSULATED METAL STAPLES



Cable Staples
page 347



Service Entrance Staples
page 347

INSULATED METAL STAPLES



Plastic Insulator Cable Staples
page 348



PVC Dipped Cable Staples
page 348

INSULATED PLASTIC STAPLES



Plastic Cable Staples
page 349



Service Entrance Staples • Style SER
page 350



Service Entrance Staples • Style SEU
page 350



Bell & Thermostat Staples
page 350



Non-Metallic Sheathed Cable Staples
page 350

DIAMOND POINT STAPLES



Square Wire Barbed Staples
page 353



Bright Wire Diamond Point Staples
pages 354–355



Electro-Zinc Diamond Point Staples
page 355

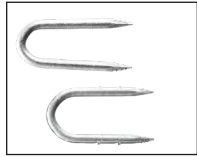

Galvanized Diamond Point Staples
page 356

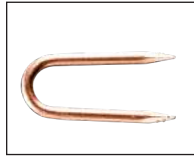

Copperclad Diamond Point Staples
page 356



Drive Stop® Diamond Point Staples
page 357



Serrated Electro-Zinc Diamond Point Staples
page 357



Electro-Zinc Flat Top Diamond Point Staples
page 357

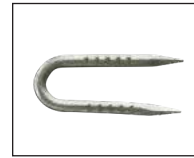

Serrated Galvanized Diamond Point Staples
page 357

CUT POINT STAPLES



Pre-Galvanized Cut Point Staples
page 358



Galvanized Cut Point Staples
page 359



Copperclad Cut Point Staples
page 359

NAILS



Copperclad Common Nails
page 360



Galvanized Marking Nails
page 360

CONDUIT HANGERS

- Our standard conduit hangers come zinc-plated or made from 304 stainless steel.
- Available with or without bolt and nut attached.
- The original conduit hanger available for ½" through 5" conduit.

Available made from aluminum, brass, or steel that has been hot dip galvanized or copper-plated. Call customer service for pricing and minimum order quantities.

See page 74 to order bolts and nuts separately.

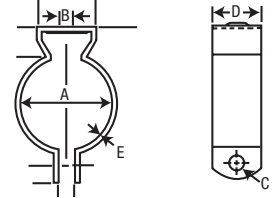
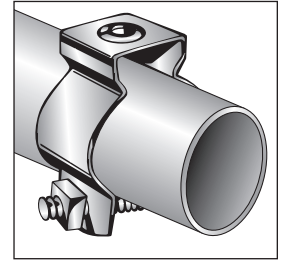

Fits Rigid/IMC	Fits EMT	Nom. Pipe O.D. A	B	C	D	E	W/O Bolt Attached Part #	With Bolt Attached Part #	Std Pkg
Zinc Plated									
¾–½	½	0.675–0.840	¼	¼	.750	.050	0 ★	0B*	100
¾	¾	0.922–1.050	¼	¼	.875	.050	1 ★	1B*	100
1	1	1.163–1.315	¼	¼	.875	.050	2 ★	2B*	100
—	1¼	1.510	¼	¼	.875	.050	2½ ★	2½B*	100
1¼	1½	1.660–1.740	¼	¼	.875	.050	3 ★	3B*	100
1½	—	1.883–1.900	⅙	¼	1.000	.060	4 ★	4B*	100
2	2	2.197–2.375	⅙	¼	1.250	.060	5 ★	5B*	50
2½	2½	2.857–2.875	⅙	¼	1.250	.060	6 ★	6B*	50
3	3	3.476–3.500	⅙	⅙	1.250	.060	7 ★	7B*	25
3½	3½	3.971–4.000	⅙	⅙	1.250	.060	8 ★	8B*	25
4	4	4.466–4.500	½	½	1.750	.080	9 ★	9B*	10
5	—	5.563	½	½	1.750	.080	10 ★	10B*	10

* Made in USA per Federal Trade Commission 1998

★ Made in USA

See page 217 for Stainless Steel.

KEYHOLE CONDUIT HANGERS

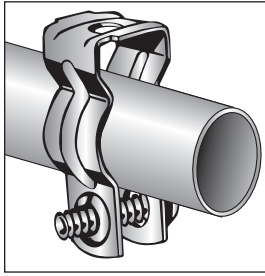

- Modeled after Minerallac's Standard Conduit Hangers, the K Series incorporates value and ease of use.
- Parts come with bolts only. Keyhole design eliminates need for nut.
- Made from pre-galvanized steel.

Our Most Economical Conduit Hanger - NO NUT NEEDED!

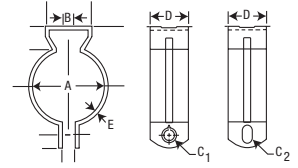

Fits Rigid/IMC	Fits EMT	Thread Imp						Part #	Std Pkg
		A	B	C ₁	C ₂	D	E		
Pre-Galvanized									
3/8-1/2	1/2	0.675-0.840	1/4	1/4-20	1/4 X 3/8	.625	.040	K0B ★	100
3/4	3/4	0.922-1.050	1/4	1/4-20	1/4 X 3/8	.750	.040	K1B ★	100
1	1	1.163-1.315	1/4	1/4-20	1/4 X 3/8	.750	.040	K2B ★	100



* Made in USA per Federal Trade Commission 1998

★ Made in USA

ONE-HOLE STRAP • JIFFY CLIP®

Minerallac has the widest variety of one-hole straps in the industry. If you can't find it at Minerallac, it probably doesn't exist.

Minerallac manufactures five grades of one-hole straps to fit any budget, any application. And many of our one-hole straps are available in other materials, and finishes—stainless steel, brass, copper-plated steel or hot dip galvanized steel.

From our most economical K-series one-hole straps to our best quality heavy-duty one-hole straps, you can't find a wider selection or better value anywhere.

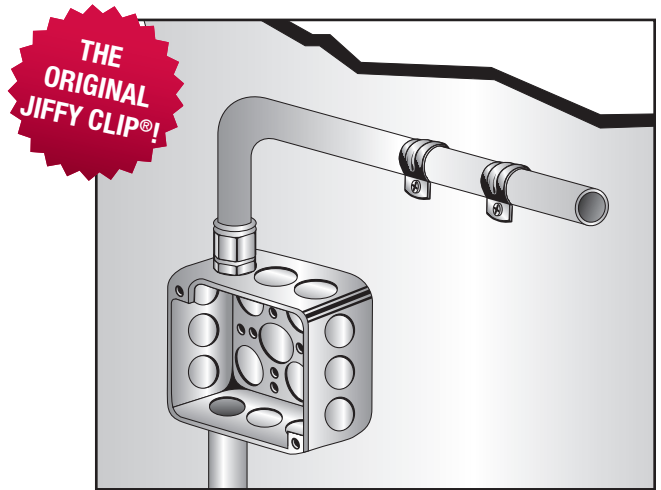

One-Hole Jiffy Clips® in Five Grades



K-Series
Most Economical



"Heavy Duty" Series
Strongest



"Standard" Series
The "original" Jiffy Clip®



"Min-E" Series
Most Value



"Medium" Series
Most Popular

K-Series

- Precision made one-hole pipe straps with snap-on feature.
- Pre-galvanized steel.

Our most economical Jiffy Clip®!

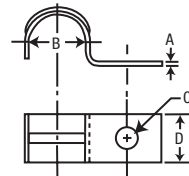

Fits EMT	Nom. Pipe O.D.				Part #	Std Pkg
	A	B	C	D		
Pre-Galvanized						
1/2	.050	0.706	1/4	0.625	K30 ★	100
3/4	.050	0.922	1/4	0.625	K45 ★	100
1	.050	1.163	1/4	0.875	K55 ★	100

★ Made in USA

ONE-HOLE STRAP • JIFFY CLIP®

HEAVY DUTY Series

- With the same original inverted rib and “Snap-On” features as the medium Jiffy Clip®, this is our strongest, heavy-duty one-hole strap series.
- Zinc plated steel.

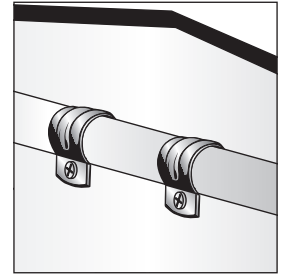
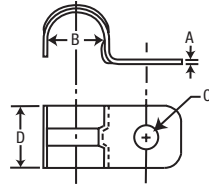

H92

Fits Rigid & IMC	Fits EMT	A	Nom. Pipe O.D. B	Bolt C	D	Part #	Std Pkg
Zinc Plated							
—	½	.120	0.706	¼	.875	H30 ★	100
½	—	.120	0.840	¼	.875	H40 ★	100
—	¾	.120	0.922	¼	.875	H45 ★	100
¾	—	.120	1.050	¼	.875	H50 ★	100
—	1	.120	1.163	¼	.875	H55 ★	100
1	—	.120	1.315	¼	.875	H60 ★	100
—	1¼	.120	1.510	⅝	1.000	H65 ★	100
1¼	—	.120	1.660	⅝	1.000	H70 ★	100
—	1½	.120	1.740	⅝	1.000	H75 ★	50
1½	—	.120	1.900	¾	1.250	H80 ★	50
—	2	.120	2.197	¾	1.250	H85 ★	25
2	—	.187	2.375	¾	1.250	H90 ★	25
2½	2½	.187	2.875	⅝	1.250	H92 ★	25
3	3	.187	3.500	⅝	1.250	H94 ★	10
3½	3½	.250	4.000	⅝	1.250	H95 ★	10
4	4	.250	4.500	⅝	1.250	H96 ★	10
5	—	.250	5.563	⅝	1.500	H97 ★	10
6	—	.250	6.625	⅝	1.500	H98 ★	10

★ Made in USA

ONE-HOLE STRAP • JIFFY CLIP® • SLOTTED COPPER

Copper Tubing O.D.	Part #	Std Pkg
Copper Plated		
¼	105SC ★	100
⅜	115SC ★	100



105SC

★ Made in USA

- Slotted Jiffy Clips® are a one-hole pipe strap with slotted mounting hole. This enables the installer to final position the clips after the run is completed.
- Copper plated steel. Parts provide compatibility with copper.
- Also available in brass. Call customer service for pricing and minimum order quantities.

ONE-HOLE STRAP • JIFFY CLIP® • ZINC PLATED

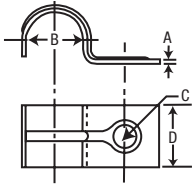

STANDARD Series

- These one-hole pipe straps are ideal for hanging tubing, pipe, conduit and BX cable.
- Pre-galvanized steel, except for items 135, 165, 160, and 170 which are zinc plated.

- Parts also available in copper plated or made from brass.

Call customer service for pricing and minimum order quantities.

Fits Tubing O.D.	Fits Rigid	Fits EMT	Marking On Clip	Nom. O.D. A	Nom. O.D. B	Bolt C	D	No. Ribs	Part #	Std Pkg
Pre-Galvanized										
1/8	—	—	—	.035	0.125	3/16	.500	1	102 ★	100
3/16	—	—	—	.035	0.1875	3/16	.500	1	103 ★	100
1/4	—	—	—	.035	0.250	3/16	.500	1	105 ★	100
5/16	—	—	—	.035	0.3125	3/16	.500	1	110 ★	100
3/8	—	—	115	.045	0.375	3/16	.625	1	115 ★	100
—	1/8	—	120	.045	0.405	3/16	.625	1	120 ★	100
—	BX: 14-2, 14-3, 12-2	—	121	.045	0.475	3/16	.625	1	121 ★	100
1/2	1/4 & BX: 12-3, 10-2, 10-3	—	125	.045	0.540	3/16	.625	1	125 ★	100
—	3/8	1/2	130	.050	0.675–0.706	1/4	.750	1	130 ★	100
3/4	—	—	750	.050	0.750	1/4	.750	1	135* ★	100
—	1/2	—	140	.050	0.840	1/4	.875	1	140 ★	100
—	—	3/4	145	.050	0.922	1/4	.875	1	145 ★	100
1	3/4	—	150	.050	1.000–1.050	1/4	.875	1	150 ★	100
—	—	1	155	.050	1.163	1/4	.875	1	155 ★	100
—	1	—	1"	.060	1.315	1/4	1.000	2	160* ★	100
1 1/2	—	1 1/4	1 1/4"	.060	1.500–1.510	1/4	1.000	2	165* ★	100
—	1 1/4	1 1/2	1 1/4"	.060	1.660–1.740	5/16	1.250	2	170* ★	100

ONE-HOLE STRAP • JIFFY CLIP® EVERDUR • BRASS



115E

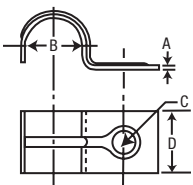

Fits Tubing O.D.	Marking On Clip	A	Nom. O.D. B	Bolt C	D	No. Ribs	Part #	Std Pkg
Brass								
1/8	—	.035	0.125	3/16	.500	1	102E ★	100
3/16	—	.035	0.1875	3/16	.500	1	103E ★	100
1/4	—	.035	0.250	3/16	.500	1	105E ★	100
5/16	—	.035	0.3125	3/16	.500	1	110E ★	100
3/8	115	.045	0.375	3/16	.625	1	115E ★	100
1/2	125	.045	0.540	3/16	.625	1	125E ★	100

MINERALLAC TRADITIONAL

ONE-HOLE STRAP • JIFFY CLIP®

MIN-E® Series

- MinE® clips have an inverted rib providing more strength at the bend of the clip. Snap-on feature leaves both hands free to work.
- Pre-galvanized steel, except for items MINE55, MINE40, and MINE50, which are zinc plated.

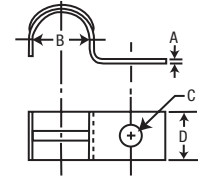

Fits EMT	A	Nom. Pipe O.D. B	Bolt C	D	Part #	Std Pkg
Pre-Galvanized						
½	.074	0.706	¼	.625	MINE30 ★	100
¾	.074	0.922	¼	.625	MINE45 ★	100
1	.090	1.163	¼	.750	MINE55* ★	100

*Zinc plated
★ Made in USA

Fits Rigid	Flexible Conduit	A	Nom. Pipe O.D. B	Bolt C	D	Part #	Std Pkg
Pre-Galvanized							
—	¾	.074	0.560	¼	.625	MINE28 ★	100
½	½	.090	0.840	¼	.750	MINE40* ★	100
¾	¾	.090	1.050	¼	.750	MINE50* ★	100

*Zinc plated
★ Made in USA

MEDIUM Series

- Our best-selling precision made one-hole conduit and pipe straps.
- Clips have an inverted rib providing more strength at the bend of the clip and holding the clip on the conduit, leaving both hands free to work.
- Both zinc plated steel and stainless steel medium Jiffy Clips® are available.
- Also available hot-dip galvanized steel. Call customer service for pricing and minimum order quantities.

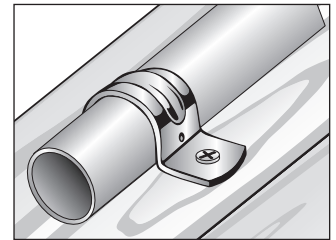
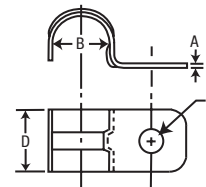

Fits EMT	Fits Rigid & IMC	A	Nom. Pipe O.D. B	Bolt C	D	Part #	Std Pkg
Zinc Plated							
½	—	.080	0.706	¼	.875	MED30 ★	100
—	½	.080	0.840	¼	.875	MED40 ★	100
¾	—	.080	0.922	¼	.875	MED45 ★	100
—	¾	.080	1.050	¼	.875	MED50 ★	100
1	—	.080	1.163	¼	.875	MED55 ★	100
—	1	.080	1.315	¼	.875	MED60 ★	100
1¼	—	.090	1.510	⅝	1.000	MED65 ★	100
—	1¼	.090	1.660	⅝	1.000	MED70 ★	100
1½	—	.090	1.740	⅝	1.000	MED75 ★	50
—	1½	.120	1.900	¾	1.000	MED80 ★	50
2	—	.090	2.197	¾	1.250	MED85 ★	50
—	2	.120	2.375	¾	1.250	MED90 ★	50

★ Made in USA

Harsh Environment Product

See page 218 for Stainless Steel.

ONE-HOLE DUPLEX • JIFFY CLIP®

- For positioning double lines, these one-hole pipe clamps are ideal for cable, tube, BX or combinations thereof.
- Pre-galvanized steel.
- Also available in brass or copper plated steel. Call customer service for pricing and minimum order quantities.

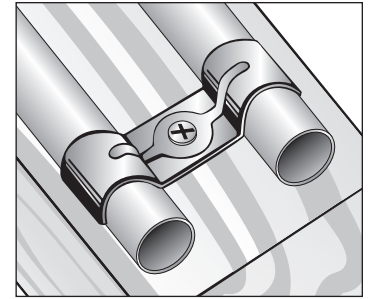
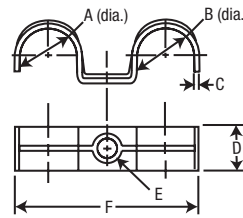

Cable or Tubing		C	D	Bolt E	F	Part #	Std Pkg
A	B						
Pre-Galvanized							
.125	.125	.035	.500	3/16	.990	300A ★	100
.250	.250	.035	.500	3/16	1.260	300 ★	100
.375	.375	.035	.500	3/16	1.570	301 ★	100
.500	.500	.035	.500	3/16	1.800	305 ★	100
Brass							
.500	.500	.035	.500	3/16	1.800	300E ★	100

300A



★ Made in USA

SLOTTED DUPLEX • JIFFY CLIP®

- For positioning double lines.
- These copper plated steel parts provide compatibility with copper.
- Other sizes are also available. Call customer service for pricing and minimum order quantities.

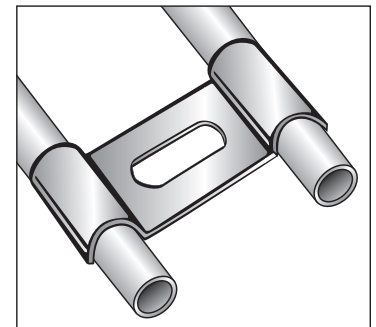
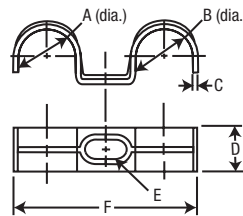

Cable or Tubing		C	D	E	F	Part #	Std Pkg
A	B						
Copper Plated							
.250	.250	.035	.500	.370	1.375	300SC ★	100
.375	.375	.035	.500	.380	1.510	301SC ★	100

300SC



★ Made in USA

CONDUIT STRAP • TWO-HOLE METAL

- Two-hole metal straps are designed for use on loads too heavy to be supported by one-hole Jiffy Clips.
- Pre-galvanized steel, except for 280, 290, 292 and 294 which are zinc plated.
- Available in zinc plated steel or made from stainless steel for corrosive environments.
- Also available in brass or hot-dipped galvanized steel. Call customer service for pricing and minimum order quantities.
- For information on Plastic Two-Hole Straps, available in nine sizes, turn to page 201.

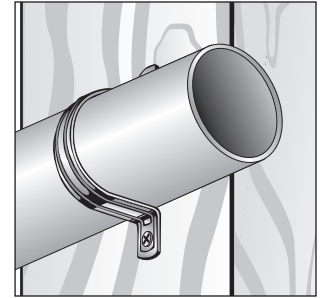
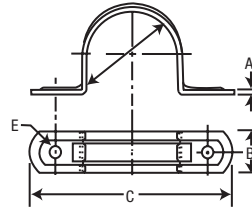

275

See page 218 for
Stainless Steel.

Fits EMT	Fits Rigid & IMC	A	B	C	Bolt E	Part #	Std Pkg
Pre-Galvanized							
—	¼	.035	.625	1.765	⅛	225 ★	100
—	⅜	.035	.750	2.515	⅜	228 ★	100
½	—	.035	.750	2.558	⅜	230 ★	100
—	½	.035	.750	2.565	⅜	240 ★	100
¾	—	.035	.750	2.765	⅜	245 ★	100
—	¾	.035	.750	2.795	⅜	250 ★	100
1	—	.035	.750	3.205	⅜	255 ★	100
—	1	.035	.750	3.140	⅜	260 ★	100
1¼	—	.050	.875	3.875	¼	265 ★	100
—	1¼	.050	.875	4.375	¼	270 ★	100
1½	—	.050	1.000	4.300	¼	275 ★	100
—	1½	.060	1.000	4.585	¼	280* ★	100
2	—	.050	1.000	5.000	¼	285 ★	100
—	2	.060	1.250	5.030	⅝	290* ★	50
2½	2½	.060	1.250	6.125	⅜	292* ★	50
3	3	.090	1.250	7.438	⅜	294* ★	25
Stainless Steel (Type 304)							
½	—	.035	.750	2.558	⅜	230SS ★ ♡	100
—	½	.035	.750	2.565	⅜	240SS ★ ♡	100
¾	—	.035	.750	2.765	⅜	245SS ★ ♡	100
—	¾	.035	.750	2.795	⅜	250SS ★ ♡	100

*Zinc plated

★ Made in USA

♡ Harsh Environment Product

MINERALLAC TRADITIONAL

CONDUIT STRAP • TWO-HOLE METAL



HD290

- Heavy-Duty Two-Hole Straps are designed for heavy loads.
- Zinc plated steel.
- Also available in hot-dipped galvanized steel. Call customer service for pricing and minimum order quantities.

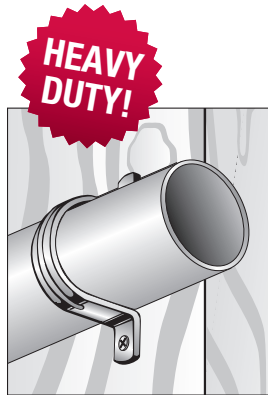
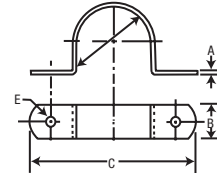

Fits Rigid & IMC	Fits EMT	A	B	C	Bolt E	Part #	Std Pkg
Zinc Plated							
1	—	.090	.750	3.092	3/16	HD260 ★	100
1¼	—	.080	.875	4.400	¼	HD270 ★	100
1½	—	.090	1.000	4.590	¼	HD280 ★	50
2	—	.090	1.250	5.100	5/16	HD290 ★	25
2½	2½	.090	1.250	6.188	3/8	HD292 ★	25
3	3	.120	1.250	7.125	3/8	HD294 ★	10
3½	3½	.187	1.250	8.750	5/8	HD295 ★	10
4	4	.187	1.250	9.063	5/8	HD296 ★	10
5	—	.250	1.250	10.680	5/8	HD297 ★	10
6	—	.250	1.250	12.140	5/8	HD298 ★	10

★ Made in USA

MULTI-USE TWO-HOLE PLASTIC STRAPS

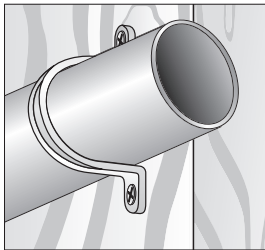

- Designed for strength.
- Easy to install. Plastic straps fit snugly over PVC or rigid conduit.
- Made from high quality UV stabilized and fire resistant material.



PS300

Trade Size	Color	Part #	Std Pkg
½	Gray	PS50 ★ ♡	50
¾	Gray	PS75 ★ ♡	50
1	Gray	PS100 ★ ♡	25
1¼	Gray	PS125 ★ ♡	25
1½	Gray	PS150 ★ ♡	25
2	Gray	PS200 ★ ♡	25
2½	Gray	PS250 ★ ♡	25
3	Gray	PS300 ★ ♡	10
4	Gray	PS400 ★ ♡	10

★ Made in USA ♡ Harsh Environment Product

MULTI-PURPOSE CLOSED CLIP



- Supports tubing pipe in sizes ¼" O.D.
- Pre-galvanized steel.

Tubing O.D.	Part #	Std Pkg
Pre-Galvanized		
¼	1105 ★	100

★ Made in USA



1105

SERVICE ENTRANCE STRAPS • ONE-HOLE

- Secures type SEU service entrance cables.
- Available in zinc plated steel or made from aluminum. MED2 and MED3 are made from pre-galvanized steel.

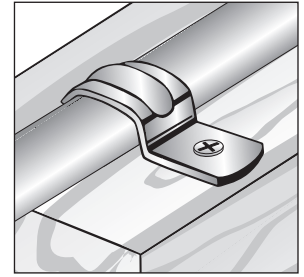
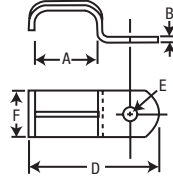

Cable Size	Inside Dia. A	B	D	Bolt E	F	Part #	Std Pkg
Zinc Plated							
NM (Romex)	.460	.045	1.080	3/16	.625	MED2* ★	100
UF	.550	.045	1.190	3/16	.625	MED3* ★	100
—	1.050	.074	2.056	1/4	.625	MED5 ★	100
6, 4	.835	.080	2.148	1/4	.875	MED7 ★	100
—	.970	.080	2.125	1/4	.875	MED9 ★	100
2	1.090	.080	2.275	1/4	.875	MED12 ★	100
1/0 & 2/0	1.275	.080	2.665	1/4	.875	MED13 ★	100
—	1.465	.120	2.880	1/4	.875	MED14 ★	100
—	1.675	.120	3.355	1/4	1.000	MED16 ★	100
—	1.209	.120	2.500	1/4	.875	H12 ★	100
4/0	1.570	.120	3.060	1/4	1.000	H16 ★	100
Aluminum							
2	1.090	.080	2.275	1/4	.875	MED12A ★ ♡	100
1/0 & 2/0	1.275	.080	2.665	1/4	.875	MED13A ★ ♡	100
4/0	1.570	.120	3.355	1/4	1.000	H16A ★ ♡	100



MED2

***Pre-galvanized**

★ Made in USA

♡ Harsh Environment Product

- Secures type SER service entrance cables.
- Pre-galvanized steel, except 160 which is zinc plated.

SER & BX Fits Rigid or BX	Part #	Std Pkg
Pre-Galvanized		
BX: 14-2, 14-3, 12-2	121 ★	100
BX: 12-3, 10-2, 10-3, SER 8	125 ★	100
6, 4	130 ★	100
2	140 ★	100
1, 1/0	145 ★	100
2/0	150 ★	100
3/0	155 ★	100
4/0	160* ★	100

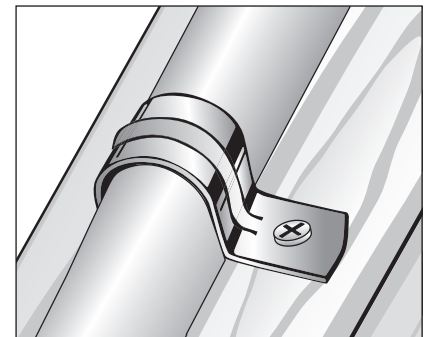

130

***Zinc plated**

★ Made in USA

SERVICE ENTRANCE STRAPS • TWO-HOLE

- Secures type SEU service entrance cables.
- Pre-galvanized steel, except 212 which is zinc plated.



221

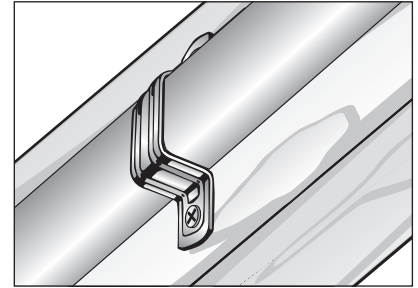
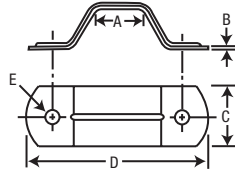

For SEU	A	B	C	D	Bolt E	Part #	Std Pkg
Pre-Galvanized							
Inside Width 0.425"	.425	.035	.750	2.070	1/8	221 ★	100
Inside Width 0.635"	.635	.050	.750	2.895	3/16	212* ★	100
2	.875	.035	.750	2.690	3/16	223 ★	100
1, 1/0, 2/0	1.100	.035	.750	3.018	3/16	2203 ★	100
3/0, 4/0	1.340	.035	.750	2.990	3/16	2403 ★	100

*Zinc plated ★ Made in USA



250

- Secures type SER and BX service entrance cables.
- Available made from pre-galvanized steel or stainless steel.

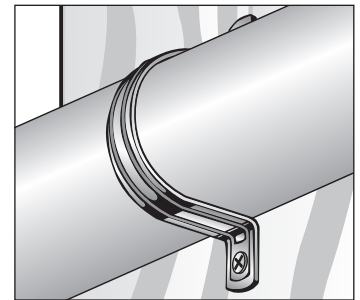
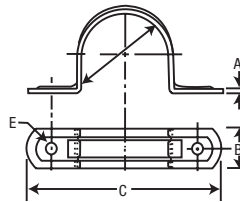



For SER & BX	A	B	C	Bolt E	Part #	Std Pkg
Pre-Galvanized						
BX, SER8	.035	.625	1.765	1/8	225 ★	100
6	.035	.750	2.515	3/16	228 ★	100
4	.035	.750	2.558	3/16	230 ★	100
2	.035	.750	2.565	3/16	240 ★	100
1, 1/0	.035	.750	2.765	3/16	245 ★	100
2/0	.035	.750	2.795	3/16	250 ★	100
3/0	.035	.750	3.205	3/16	255 ★	100
4/0	.035	.750	3.140	3/16	260 ★	100

★ Made in USA ⚡ Harsh Environment Product

NAIL STRAPS • COMBO EMT/RIGID • STAMPED

- For rigid, IMC or EMT conduit.
- Flat nail straps are made from pre-galvanized steel.
- Barbs on flat nail straps minimize back-out.



		 Cardboard Box		 Gravity Feed Jar		
Description	Gauge	Part #	Box Qty	Part #	Jar Qty	Master Carton
½ EMT or ¾ Rigid Pipe	12	90108 ★	100	90108J ★	100	600
¾ EMT or ½ Rigid Pipe	12	90112 ★	100	90112J ★	100	600
1 EMT or ¼ Rigid Pipe	12	90116 ★	100	90116J ★	100	600

★ Made in USA

MINERALLAC TRADITIONAL

ROUND NAIL STRAPS • COMBO EMT/RIGID • ZINC



- Drives like a nail. Fast and easy to install.
- For rigid, IMC or EMT conduit.
- Knurling on shank of round nail straps minimize back out.
- Round nail straps are zinc plated after fabrication.

Description	Gauge	Part #	Box Qty
½ EMT or ¾ Rigid Pipe	12	90109 ★	100
¾ EMT or ½ Rigid Pipe	12	90113 ★	100
1 EMT or ¾ Rigid Pipe	12	90117 ★	100

★ Made in USA

BEAM CLAMPS • UNIVERSAL

- Used with Minerallac conduit hangers #0 to #5, bridle rings and threaded rod. Tapped for rods bottom and back except #602 (bottom only).
- Case hardened steel set screw tapped at an angle locks on beam.
- Available in zinc plated steel or made from stainless steel.

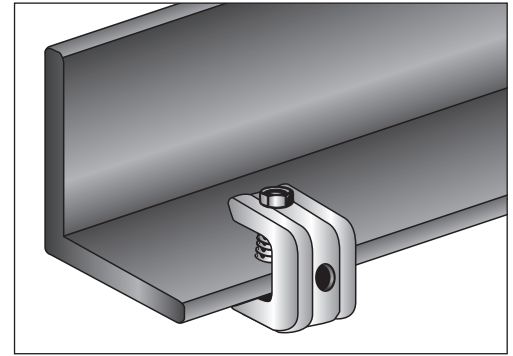
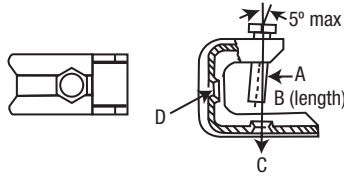

Fits Flange	Tapping	Drop Rod	Static Load Limit Bottom Hole Only	Screw Diameter A	Screw Length B	Bottom Thread C	Back Thread D	Part #	Std Pkg
Zinc-Plated Steel									
1/2	1/4"-20	1/4	75 lbs	1/4"-20	1	1/4"-20	1/4"-20	600 ★	50
1/2	#10-24	#10-24	75 lbs	1/4"-20	1	10-24	10-24	60010 ★	50
3/4	3/8" Bottom Only	3/8	200 lbs	5/16"-18	1 3/8	3/8"-16	None	602 ★	25
3/4	3/8"-16	3/8	200 lbs	5/16"-18	1 3/8	3/8"-16	3/8"-16	602B ★	25

★ Made in USA Harsh Environment Product

See page 219 for Stainless Steel.

BEAM CLAMPS • MALLEABLE

- Used with Conduit Hangers, Bridle Rings and Drop Rods, 3/8" to 1/2". Tapped for rods bottom and back on all sizes.
- Malleable iron zinc plated.

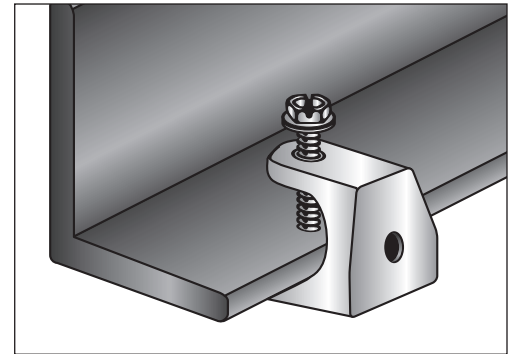
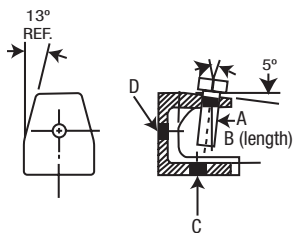

Fits Flange	Tapping	Drop Rod	Static Load Limit Bottom Hole Only	Screw Diameter A	Screw Length B	Bottom Thread C	Back Thread D	Part #	Std Pkg
Zinc Plated Malleable Iron									
5/8	1/4"-20	1/4	275 lbs	5/16"-18	1 1/4	1/4"-20	1/4"-20	700	50
3/4	#10-24	#10-24	275 lbs	1/4"-20	1 1/4	10-24	10-24	70010	50
3/4	5/16"-18	5/16	525 lbs	3/8"-16	1 1/4	5/16"-18	5/16"-18	701	25
3/4	3/8"-16	3/8	750 lbs	1/2"-13	1 1/2	3/8"-16	3/8"-16	702	25
7/8	1/2"-13	1/2	900 lbs	5/8"-11	1 1/2	1/2"-13	1/2"-13	703	25

MINERALLAC TRADITIONAL

BEAM CLAMP ASSEMBLIES

- Our #600 beam clamp with #0 through #5 Conduit Hangers attached.
- Offered with or without nut and bolt attached.
- Zinc plated steel.

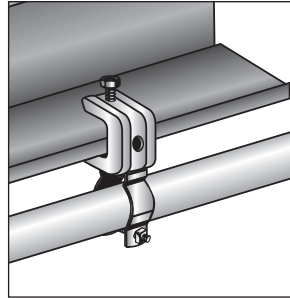

Fits EMT	Fits Rigid/MC	Part #	Std Pkg
Zinc Plated Without Bolt			
1/2	3/8-1/2	A0600 ★	100
3/4	3/4	A1600 ★	100
1	1	A2600 ★	100
1 1/4	—	A2-1/2 600 ★	100
1 1/2	1 1/4	A3600 ★	100
—	1 1/2	A4600 ★	50
2	2	A5600 ★	50
Zinc Plated With Bolt			
1/2	3/8-1/2	A0600B	100
3/4	3/4	A1600B	100
1	1	A2600B	100
1 1/4	—	A2-1/2 600B	100
1 1/2	1 1/4	A3600B	100
—	1 1/2	A4600B	50
2	2	A5600B	50

* Made in USA per Federal Trade Commission 1998

★ Made in USA

FLANGE/T-BAR CLIP • TWO-PIECE

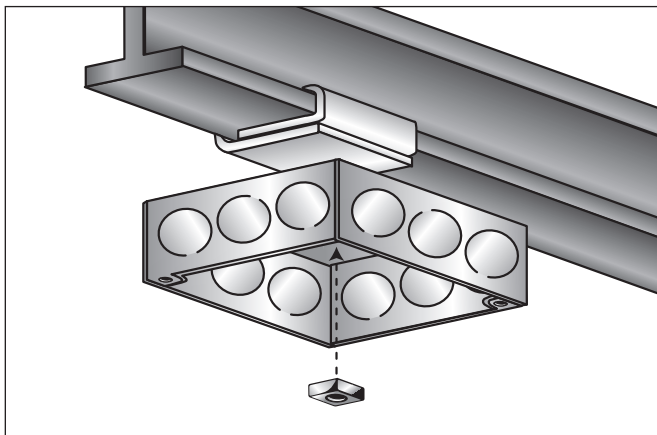

Static Load Limit: 100 lbs

- Fits flanges from 1 5/8" to 2 5/8" width and up to 1/4" thick.
- 1/4"-20 stud with nut.
- Zinc plated steel.

Fits Conduit	Part #	Std Pkg
Zinc Plated		
Fits 1 5/8" to 2 5/8" Wide Flanges; Up to 1/4" Thick	2SC4	100

OUTLET RETAINER

- Mounts standard outlets and wall switches in oversize openings, lending stability and preventing broken cover plates.
- Made from pre-galvanized steel.

Description	Part #	Std Pkg
Mounts Standard Outlets In Oversize Openings	OR ★	100

★ Made in USA

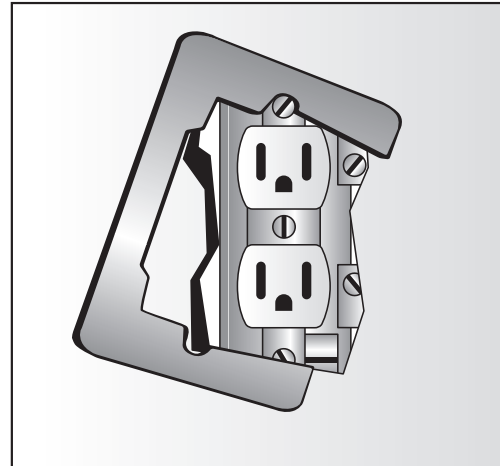

MINERALLAC TRADITIONAL

BOX MOUNTING BRACKET

- Bracket supports electrical boxes from floor or channels.
- Can be used at three heights.
- Made from pre-galvanized steel.

Description	Part #	Std Pkg
Break-A-Way Feature for 12", 16", 18" Lengths	BS18 ★	50
18" Floor Mount Box Support	FMBS184S	50

★ Made in USA

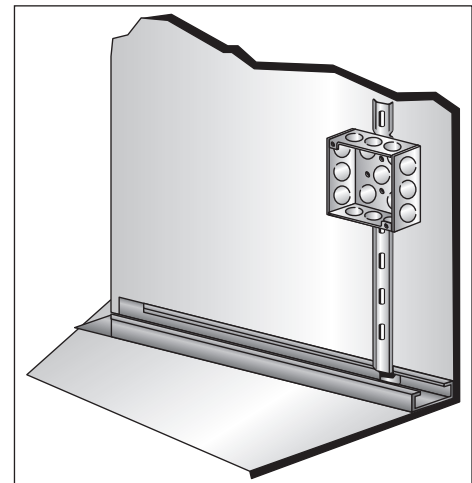

BOX STABILIZER SUPPORT • PRE-GALVANIZED STEEL

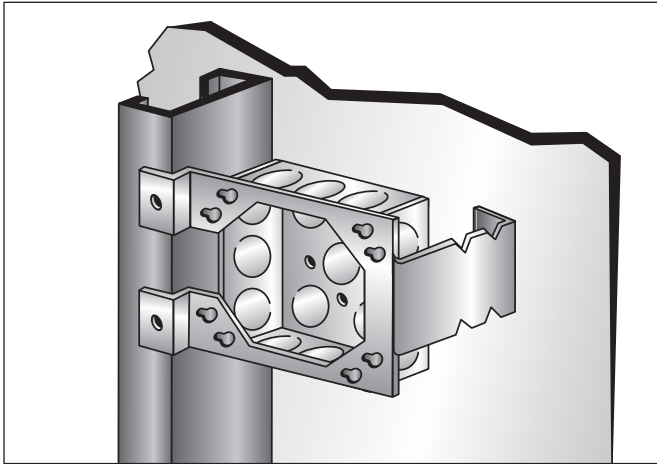

Description	Part #	Std Pkg
Box Support for 2½" and 3½" Wood or Metal Studs	FB023 ★	100
Double Sided Mount Box Support	FB023DS ★	100
Heavy Duty Box Support	FB023HD ★	100
Box Support for 2½", 3½" and 4" Wood or Metal Studs	FB0234 ★	100
Double Sided Mount Box Support	FB0234DS ★	100
Box Support for 6" Wood or Metal Studs	FB06 ★	100

★ Made in USA



FB0234DS

BOX SUPPORTS • SCREWLESS DESIGN • PRE-GALVANIZED STEEL

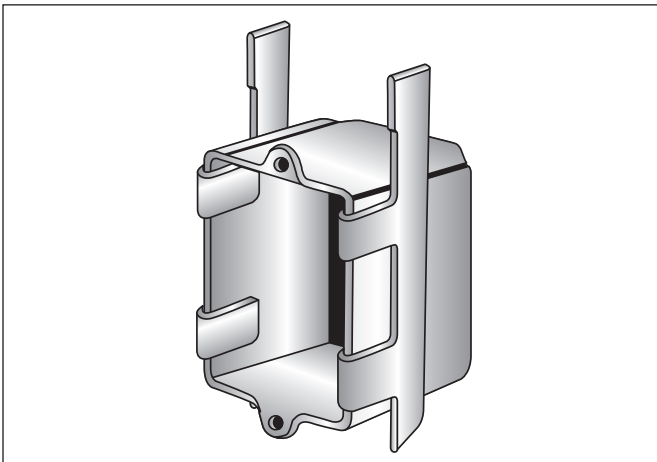

- Holds switch boxes and outlets firmly in place.
- Quick installation.
- One-piece break-away design.
- Box is supported by drywall. No stud is necessary.
- Prevents box from pulling out of drywall.
- Made from pre-galvanized steel.

Description	Part #	Std Pkg
Secures Electrical Box to Finished Drywall	BST ★	100 Sets

★ Made in USA



BST

PLASTIC FAR SIDE BOX SUPPORT

- No tools required. Mounts quickly in the back of the box. Just push in and snap tight.
- Designed for 3⁵/₈" steel studs.
- May be used on standard 1¹/₂" or 2¹/₈" deep boxes.

Description	Part #	Std Pkg
Designed for use with 3 ⁵ / ₈ " steel studs. May be used on standard 1 ¹ / ₂ " boxes or 2 ¹ / ₈ " deep boxes.	DLS1	100

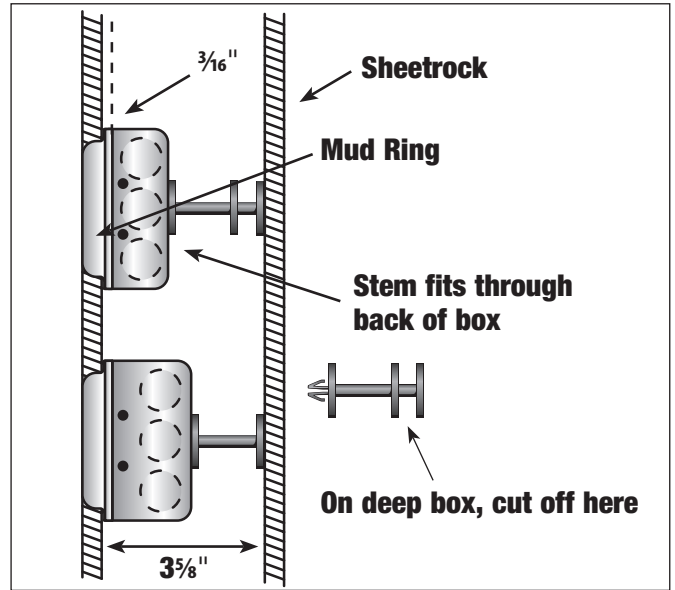

MINERALLAC TRADITIONAL

T-BAR HANGER • TWO PIECE

- Mounts fixtures or boxes to 1" T-bar with Ultimate Static Load Limit of 75 lbs.
- Stud is flat head, square shoulder carriage bolt which will not turn when positioned in slot. Assembled with 1" O.D. wing nut washer.

Description	Part #	Std Pkg
Has 1/4"-20 x 5/8" Stud with Wing Nut and Washer	SCT2	100

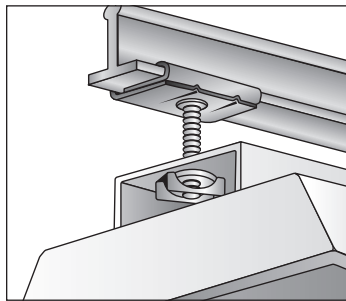

T-BAR SCISSOR CLIPS

- Two-piece zinc plated clip used for mounting fixtures or boxes to 1" T-bar with Ultimate Static Load Limit of 100 lbs.
- Includes wing nut washer.

For Use With		Part #	Std Pkg
Stud Length	T-Bar		
5/8"	1"	SCX1W ★	50
2"	1"	SCX1XL ★	50

★ Made in USA

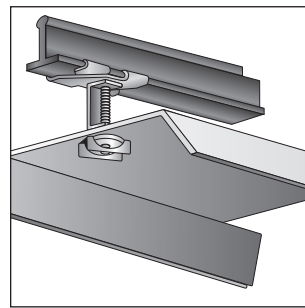

T-BAR DROP WIRE CLIP

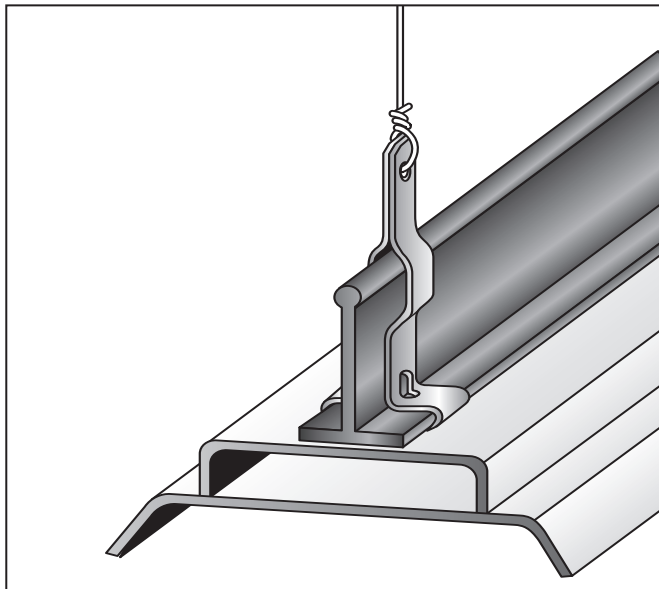

- These pre-galvanized clips support fixtures transmitting the weight of the fixture directly to the building structure, thus relieving the tee grid from any load stress. Also adds rigidity and support for truer alignment of the tee grid. Made from one-piece construction to accommodate various styles of tee grid.
- Includes wing nut washer.

For Use With		Part #	Std Pkg
Stud Length	T-Bar		
5/8"	1"	DWC1	50



CABLE SUPPORT • J-HOOKS

Another Solution for Today's Challenging Installations!

The new 2" J-Hook cable support system, designed to be versatile, can be attached to a wide variety of structures using beam clamps, clips, and many other support components available from Minerallac. The wide-base support eliminates the undesirable impact of point-loads that can cause band-width deterioration and damage to Category 5 and 6, fiber-optic, and other sensitive cables. This unique system saves both time and labor - another efficient method of cable installation!

J-Hook Cable System

- Cost effective alternative to expensive cable tray.
- Accommodates Category 5 and 6, fiber-optic, and interduct.
- Provides support without stress to sensitive voice/data cables.
- Continuous wide-base radius supports natural curve of cable, eliminating kinking, bending, and crimping.
- Cable wire retainer is supplied with every part.

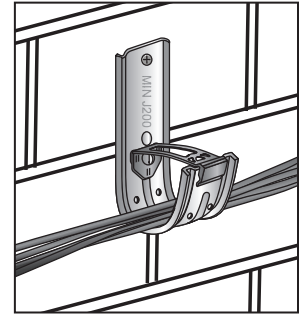

Fig 1



Fig 2



Fig 3



Fig 4



Fig 5



Fig 6



Fig 7



Fig 8



Fig 9



Fig 10



Fig 11

Description	Fig	Part #	Std Pkg
2" J-Hook	1	J200 ★	50
2" J-Hook with Bracket	2	J200B ★	50
Hammer On – 1/6–1/4 Angled Z Purlin	3	J200ABC25 ★	50
Fits #12 Wire Thru 3/8" Rod and 1/8–3/8 Flange	4	J200APS ★	50
Hammer On – 1/8–1/4 Flange	5	J200SFC18 ★	50
Hammer On – 5/16–1/2 Flange	5	J200SFC516 ★	50
Hammer On – 9/16–3/4 Flange	5	J200SFC916 ★	50
Hammer On – 1/6–1/4 Vertical Flange	6	J200VBC25 ★	50
Screw On – Up To 1/2" Flange	7	J200600 ★	50
Screw On – Up To 1/2" Flange	8	J200500	50
Hammer On – 1/8–1/4 Flange	9	J200BBC18 ★	50
Hammer On – 5/16–1/2 Flange	9	J200BBC516 ★	50
Hammer On – 9/16–3/4 Flange	9	J200BBC916 ★	50
Screw On – Up To 1/2" Flange	10	J200B600 ★	50
Screw On – Up To 1/2" Flange	11	J200B500	50

★ Made in USA

MINERALLAC TRADITIONAL

CABLE SUPPORT • BRIDLE RINGS

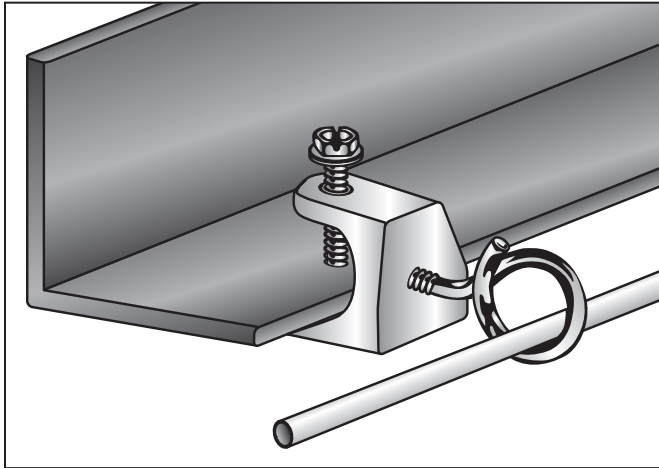

- Supports communications cable and other low voltage uses. Can be used with Minerallac Beam Clamps.
- Zinc plated steel.
- Also available in stainless steel. Call Customer service for pricing and minimum order quantities.

Ring Size	Thread	Part #	Std Pkg
1" Diameter	10-24	634R ★	100
1½" Diameter	¼"-20	646R ★	100
2" Diameter	¼"-20	648R ★	100
4" Diameter	¼"-20	654R ★	50

★ Made in USA



648R

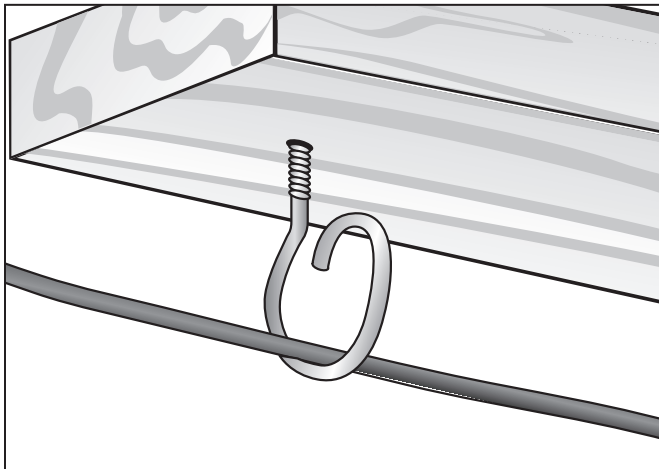

- Supports communications cable and other low voltage uses from wood beams.
- Zinc plated steel.
- Also available in stainless steel. Call Customer service for pricing and minimum order quantities.

Ring Size	Thread	Part #	Std Pkg
1" Diameter	⅜	634RW ★	100
1½" Diameter	¼	646RW ★	100
2" Diameter	¼	648RW ★	100

★ Made in USA



648RW

CABLE SUPPORT • BRIDLE RINGS

- Cost effective alternative to cable tray.
- Wide surface saddle provides support without stress for Category 5 and 6, fiber-optic and other sensitive voice/datacom cables.
- Available as assembled units or saddle only for retrofit.
- Saddle molded onto 4" bridle ring.

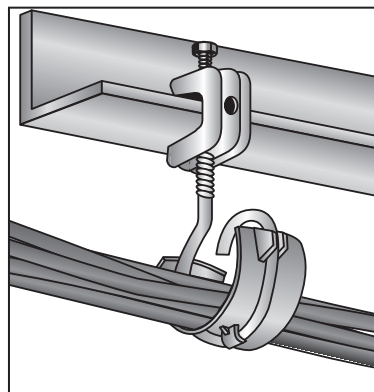

Saddle Assembly Description	Part #	Std Pkg
Mechanical Thread		
1½" Bridle Ring with Saddle	646RS ★	50
2" Bridle Ring with Saddle	648RS ★	50
4" Bridle Ring with Saddle	654RS ★	50
Lag Thread		
1½" Bridle Ring with Saddle	646RWS ★	50
2" Bridle Ring with Saddle	648RWS ★	50



BRS2

US Patent No. 6,325,338



648RS

Saddle Only Description	Part #	Std Pkg
Snaps into 1½" Bridle Ring	BRS15 ★	100
Snaps into 2" Bridle Ring	BRS2 ★	100

★ Made in USA

UNIVERSAL PLASTIC METAL STUD GROMMET

- Protects wires from damage by metal studs.
- Easy to install—no tools required.
- Complies with 2011 NEC Article 300.4B/(1).

Description	Part #	Std Pkg
Grommets for Metal Studs	G100 ★	100

★ Made in USA



G100

CABLE PROTECTION • NAIL PLATES



BJNP



NP6



BJNPH



NP6M



NP3



NP12



NP18

- Protects data/com, PVC plumbing and electrical from punctures by nails or screws.
- Styles with teeth attach to wood studs with hammer.
- Styles with holes attach to wood or metal studs using nails or screws and a hammer or screwdriver.
- Required for compliance with 2011 NEC Article 300.4(A) or Plumbing Code 305.8.
- Constructed from pre-galvanized steel for corrosion resistance.

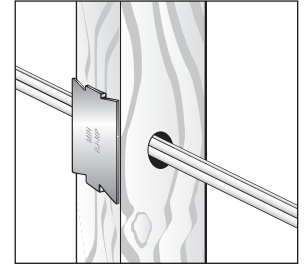

Size (L x W)	Part #	Std Pkg
2½ x 1½	BJNP ★	100
2½ x 1½	BJNPH ★	100
3 x 1½	NP3 ★	100
6 x 1½	NP6 ★	50
6 x 1½	NP6M ★	100
12 x 1½	NP12 ★	50
18 x 1½	NP18 ★	50

★ Made in USA

NAIL PLATES (SAFETY PLATES) • 16 GAUGE

- Prevents drills and fasteners from penetrating framed-in cables and plastic pipes.
- Required for 2011 NEC Article 300.4(A) or Plumbing Code 305.8.



Length (L x W)	Gauge	Part #	Box Qty	Bucket Qty
3 x 1½	16	90100 ★	100	—
3 x 1½	16	90500 ★	500	—
3 x 1½	16	90505 ★	—	500
5 x 2	16	90600 ★	100	—
5 x 3	16	90605 ★	100	—

★ Made in USA

CABLE SUPPORT • D-RINGS

- Used to support multiple cable runs.
- Smooth non-conductive surface won't damage cable.
- Lower cost than steel distribution rings (D-rings).
- Parts made from high-strength, UV stabilized non-metallic composite.

Ring Size (H x W) Inside Opening	Part #	Std Pkg
2 ¼ x 2	DR20 ★ ♣	50
3 ¼ x 3	DR30 ★ ♣	25
3 ¼ x 5	DR40 ★ ♣	10

★ Made in USA ♣ Harsh Environment Product

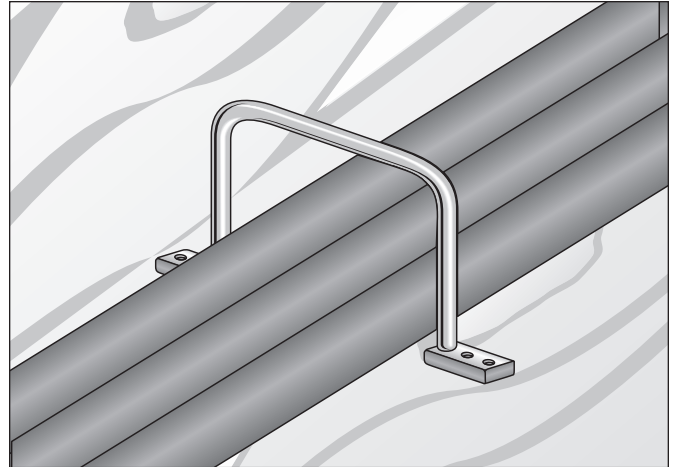

LOW VOLTAGE MOUNTING BRACKET

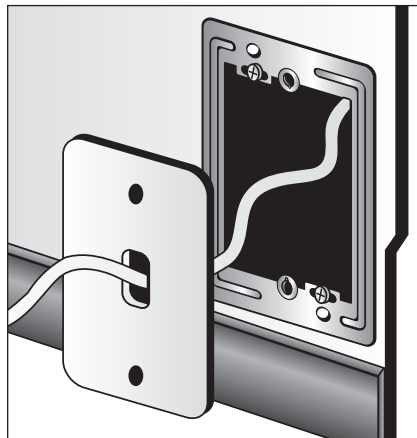

WBF1

- Provides base for securing communications lines without use of electrical box. Mounts standard plate.
- Hardware included.
- Made from pre-galvanized steel.

Description	Part #	Std Pkg
Mounts Standard Low Voltage Plates	WBF1	100

STOVE BOLT WITH NUT



- Available in zinc plated steel, aluminum or stainless steel.

Thread	Length	Part #	Std Pkg
Zinc Plated			
¼"-20	1	25516	100
¼"-20	1¼	25520	100
¼"-20	1½	25524	100
Aluminum			
¼"-20	1¼	9410A ♠	100
Stainless Steel (18-8)			
¼"-20	1	25516SSJ ♠	100
¼"-20	1¼	25520SSJ ♠	100
¼"-20	1½	25524SSJ ♠	100

♠ Harsh Environment Product

WING NUT WASHER

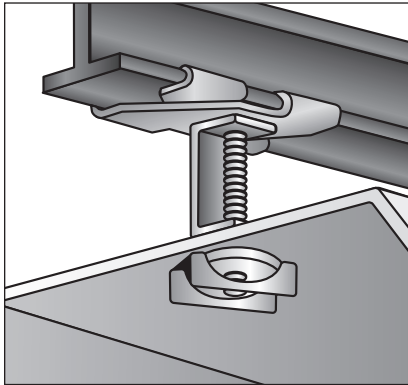

14WNW

- Made from zinc plated steel.

Wing Nut Washer Combo	Part #	Std Pkg
Fits ¼"-20 Bolt	14WNW ★	100

★ Made in USA

PERFORATED STRAPPING

- Used for hanging large size pipe or duct.
- Pre-galvanized steel.
- Other lengths of 0.035" x 3/4" and 0.050" x 7/8" perforated strapping available. Call Customer service for pricing and minimum order quantities.

Perforated Strap	Part #	Std Pkg
Pre-Galvanized 0.035" x 3/4"		
10' Coils	410C ★	100'
100' Coils	410C100 ★	100'
Pre-Galvanized 0.050" x 7/8"		
10' Coils	478C ★	100'

★ Made in USA



410C100

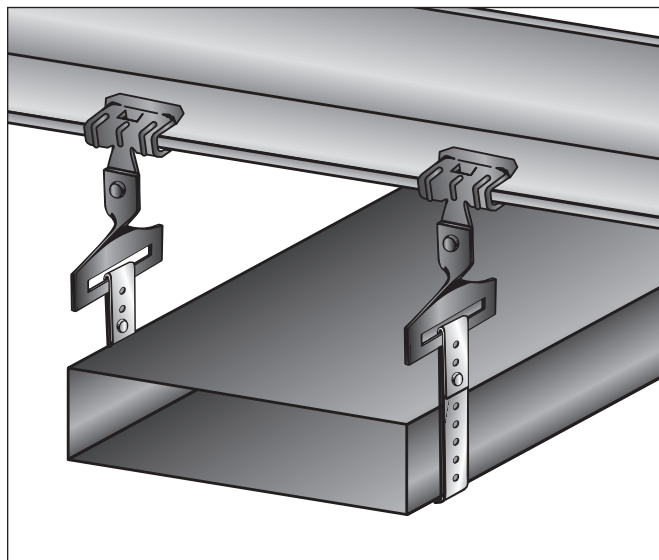

STUD CLIP ADAPTER

- Right angle fixture for attaching "S" hooks, or Jack Chain to drop rods, scissor clips or stud clips.
- Used with SCX1X, 2SC4, SCT3 and SCT2.
- Zinc plated steel.

Description	Part #	Std Pkg
For "S" Hooks or Fixture Chain	SCH48 ★	100

★ Made in USA



SCH48

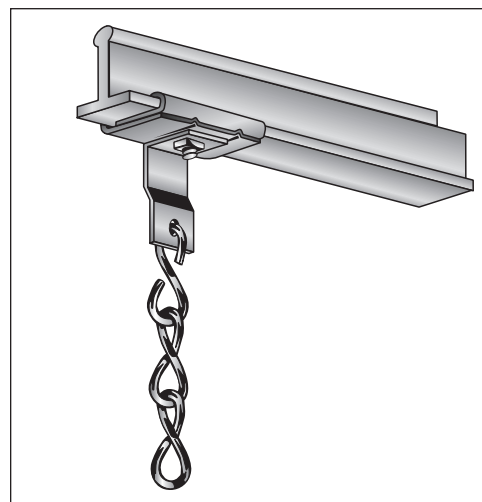

BRACKETS

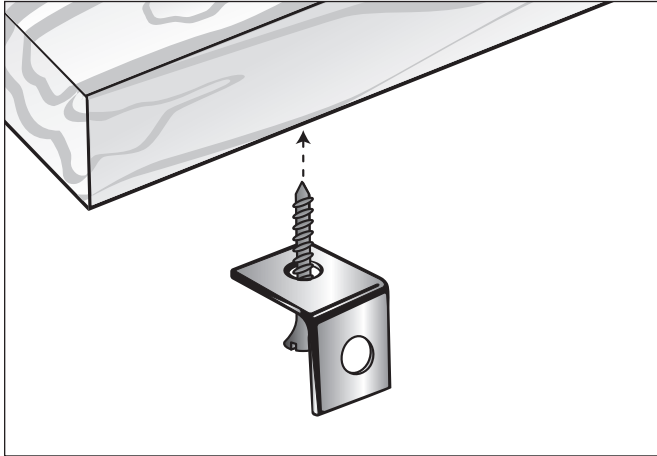

- These components, used riveted to other Minerallac products, are available separately for a variety of applications.
- Pre-galvanized steel.

Bolt Size	Part #	Std Pkg
Angle Bracket		
1/4" Mounting Hole	BA ★	100
Offset Bracket		
1/4" Mounting Hole	BO ★	100

★ Made in USA



BAR JOIST WASHERS

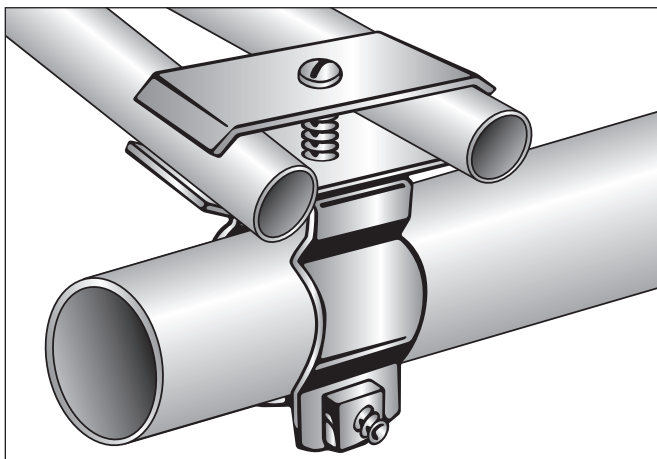

- Durable, rugged washers simplify and speed up the job of hanging conduit from bar joists.
- Zinc plated steel.

Bolt Size	Part #	Std Pkg
1/4	BJW4 ★	50 Pr
3/8	BJW6 ★	50 Pr

★ Made in USA



BJW4



Quality For Tough Applications

Minerallac Stainless Steel offers a comprehensive selection of Stainless Steel hardware, including: Hangers, Straps, Clamps, Nuts, Washers, Screws, Bolts, Anchors, Couplings, and more. Offering a full selection of Stainless Steel hardware for the toughest applications. With hundreds of products offered in one or more varieties of Stainless Steel, including 18-8, 304, 316, and 410, Minerallac offers the most complete range of Stainless Steel products in the industry.

- 217 Conduit Hangers**
- 218 Conduit Straps**
- 219 Beam Clamps**
- 220-223 Strut Accessories**
- 224-225 Hex Nuts**
- 226-229 Washers**
- 230-233 Hex Head Cap Screws**
- 234-237 Hex Head Tap Bolts**
- 238 Hex Head Lag Bolts**
- 238 Carriage Bolts**
- 239-241 Anchors**
- 242-246 Machine Screws**
- 247-248 Tamperproof Machine Screws**
- 249-252 Sheet Metal Screws**
- 253-254 Tamperproof Sheet Metal Screws**
- 255 Tek Screws**
- 256 Threaded Rod**
- 256 Hex Rod Coupling**
- 257-258 Fixture Hanging Hardware**
- 258 Tools**



Stainless Steel Type	Properties
18-8	Most common designation for non-magnetic stainless steel fasteners. Corrosion-resistant.
304	Most popular stainless steel for hex head cap screws. Increased welding capacity. Resists most oxidizing acids and can withstand all ordinary rusting. Non-magnetic.
316	Increased corrosion resistance to chloride and sulfides. Increased welding capacity. Non-magnetic.
410	Increased strength. Ideal for highly stressed conditions. Magnetic.



CONDUIT HANGERS: TYPE 304

Fits Rigid/IMC	Fits EMT	Part #	Box Qty
3/8" - 1/2"	1/2"	0S ★ ♡	100
3/4"	3/4"	1S ★ ♡	100
1"	1"	2S ★ ♡	100
—	1 1/4"	2 1/2S ★ ♡	100
1 1/4"	1 1/2"	3S ★ ♡	100
1 1/2"	—	4S ★ ♡	100
2"	2"	5S ★ ♡	50
2 1/2"	2 1/2"	6S ★ ♡	50
3"	3"	7S ★ ♡	25
3 1/2"	3 1/2"	8S ★ ♡	25
4"	4"	9S ★ ♡	10



- ★ Made in USA
- ♡ Harsh Environment Product

CONDUIT HANGERS WITH BOLT: TYPE 304

- Minerallac's original conduit hanger available with or without bolt and nut attached.

Fits Rigid/IMC	Fits EMT	Part #	Box Qty
3/8" - 1/2"	1/2"	0SB ★ ♡	100
3/4"	3/4"	1SB ★ ♡	100
1"	1"	2SB ★ ♡	100
—	1 1/4"	2 1/2SB ★ ♡	100
1 1/4"	1 1/2"	3SB ★ ♡	100
1 1/2"	—	4SB ★ ♡	100
2"	2"	5SB ★ ♡	50
2 1/2"	2 1/2"	6SB ★ ♡	50
3"	3"	7SB ★ ♡	25
3 1/2"	3 1/2"	8SB ★ ♡	25
4"	4"	9SB ★ ♡	10



* Made in USA per Federal Trade Commission 1998

- ★ Made in USA
- ♡ Harsh Environment Product

STAINLESS STEEL

1-HOLE CONDUIT STRAPS: TYPE 304



- Minerallac's best selling precision-made one-hole conduit and pipe straps.
- Clips have inverted rib providing more strength at the bend of the clip and holding the clip on the conduit, leaving both hands free to work.

Fits Rigid/IMC	Fits EMT	Part #	Box Qty
—	1/2"	MED30SS ★ ♡	100
1/2"	—	MED40SS ★ ♡	100
—	3/4"	MED45SS ★ ♡	100
3/4"	—	MED50SS ★ ♡	100
—	1"	MED55SS ★ ♡	100
1"	—	MED60SS ★ ♡	100
—	1 1/4"	MED70SS ★ ♡	100
1 1/2"	—	MED80SS ★ ♡	50
—	2"	MED90SS ★ ♡	50

★ Made in USA

♡ Harsh Environment Product

2-HOLE CONDUIT STRAPS: TYPE 304



- Two-hole stainless steel straps are designed for use on loads too heavy to be supported by one-hole Jiffy Clips.

Fits Rigid/IMC	Fits EMT	SER Cable	Part #	Box Qty
—	1/2"	#4	230SS ★ ♡	100
1/2"	—	#2	240SS ★ ♡	100
—	3/4"	#1, 1/0	245SS ★ ♡	100
3/4"	—	2/0	250SS ★ ♡	100

* Made in USA per Federal Trade Commission 1998

★ Made in USA

♡ Harsh Environment Product

STAINLESS STEEL

BEAM CLAMP: TYPE 304

- Used with Minerallac conduit hangers #0 to #5, bridle rings, and threaded rod.
- Tapped for rods bottom and back.
- Stainless steel set screw tapped at an angle locks on beam.
- Fits Up to 3/4" Flange, 3/8"-16 Tapped Holes Bottom & Back of Beam Clamp



Description	Part #	Box Qty
Fits Up to 3/4" Flange	602BSS ★ ♡	25

★ Made in USA

♡ Harsh Environment Product

BEAM CLAMP: TYPE 316

- Used with Minerallac conduit hangers #0 to #5, bridle rings, and threaded rod.
- Tapped for rods bottom and back.
- Stainless steel set screw tapped at an angle locks on beam.



Description	Part #	Box Qty
Fits Up to 3/4" Flange, 1/4"-20 Tapped Holes Bottom & Back of Beam Clamp	600SS316 ♡	50
Fits Up to 3/4" Flange, 3/8"-16 Tapped Holes Bottom & Back of Beam Clamp	602BSS316 ♡	25

♡ Harsh Environment Product

STRUT ACCESSORIES: TYPE 304

- Expansive line of Stainless Steel fittings, clamps and hardware for strut systems.
- Most popular grade of Stainless Steel.
- Increased welding capacity.



Description	Part #	Box Qty
Beam Clamp to Strut with U-Bolt for 1 ³ / ₁₆ " & 1 ⁵ / ₈ " Channel	BCSU162S4 ★ ♡	25
Beam Clamp to Strut with U-Bolt for 2 ⁷ / ₁₆ " & 3 ¹ / ₄ " Channel	BCSU325S4 ★ ♡	25
1/4" Square Washer	SW025S4 ★ ♡	100
3/8" Square Washer	SW037S4 ★ ♡	100
1/2" Square Washer	SW050S4 ★ ♡	100
5/8" Square Washer	SW062S4 ★ ♡	100
3/4" Square Washer	SW075S4 ★ ♡	100
4-Hole Splice Plate	SP4HS4 ★ ♡	25
3-Hole Corner Plate	CP3HS4 ★ ♡	25
4-Hole Tee Plate	TP4HS4 ★ ♡	20
5-Hole Cross Plate	XP5HS4 ★ ♡	15
2-Hole Corner Angle	CA2HS4 ★ ♡	50
4-Hole Corner Angle	CA4HS4 ★ ♡	25
2-Hole Cross Corner Angle	CAX2HS4 ★ ♡	50
3-Hole Long Corner Angle	CA3HLS4 ★ ♡	25
3-Hole 3-Way Corner Angle	CA3H3WS4 ★ ♡	25
4-Hole 3-Way Corner Angle	CA4H3WS4 ★ ♡	25
2-Hole Open 45 Degree Corner Angle	CA02H45S4 ★ ♡	25
2-Hole Closed 45 Degree Corner Angle	CAC2H45S4 ★ ♡	25

★ Made in USA

♡ Harsh Environment Product

STAINLESS STEEL

STRUT ACCESSORIES: TYPE 304

- Expansive line of Stainless Steel fittings, clamps, and hardware for strut systems.
- Most popular grade of Stainless Steel.
- Increased welding capacity.

Description	Gravity Feed Jar	
	Part #	Jar Qty/Box
Post Base Single Channel, 2-Hole Square 3½"	PBS2H350SQS4 ★ ♡	5
Post Base Single Channel, 2-Hole Square Flush 3½"	PBS2H350FLS4 ★ ♡	5
Post Base Single Channel, 4-Hole Standard 1⅝"	PBS4H162S4 ★ ♡	5
Post Base Single Channel, 4-Hole Standard 3½"	PBS4H350S4 ★ ♡	5
Post Base Single Channel, 4-Hole Square 3½"	PBS4H350SQS4 ★ ♡	5
Post Base Double Channel, 4-Hole Standard 3½"	PBD4H350S4 ★ ♡	5
Post Base Double Channel, 4-Hole Square 3½"	PBD4H350SQS4 ★ ♡	5
Conduit Strut Clamp, Fits ½" Rigid	CCR050S4 ★ ♡	100
Conduit Strut Clamp, Fits ¾" Rigid	CCR075S4 ★ ♡	100
Conduit Strut Clamp, Fits 1" Rigid	CCR100S4 ★ ♡	100
Conduit Strut Clamp, Fits 1¼" Rigid	CCR125S4 ★ ♡	50
Conduit Strut Clamp, Fits 1½"	CCR150S4 ★ ♡	50
Conduit Strut Clamp, Fits 2" Rigid	CCR200S4 ★ ♡	50
Conduit Strut Clamp, Fits 2½" Rigid	CCR250S4 ★ ♡	50
Conduit Strut Clamp, Fits 3" Rigid	CCR300S4 ★ ♡	25
Conduit Strut Clamp, Fits 3½" Rigid	CCR350S4 ★ ♡	25
Conduit Strut Clamp, Fits 4" Rigid	CCR400S4 ★ ♡	25
Conduit Strut Clamp, Fits 5" Rigid	CCR500S4 ★ ♡	25
Conduit Strut Clamp, Fits 6" Rigid	CCR600S4 ★ ♡	25
Conduit Strut Clamp, Fits 8" Rigid	CCR800S4 ★ ♡	25
U-Fitting Cross 5-Hole, 1⅝" Channel	UFX5H162S4 ★ ♡	20
U-Fitting Splice 4-Hole, 1⅝" Channel	UFS4H162S4 ★ ♡	10
Wing Fitting Corner Connector, 8-Hole Opposed	WF08HS4 ★ ♡	10
Z-Fitting Cross 2-Hole, 1⅝" Channel	FZX2H162S4 ★ ♡	25

★ Made in USA

♡ Harsh Environment Product



STRUT ACCESSORIES: TYPE 316

- Expansive line of Stainless Steel fittings, clamps and hardware for strut systems.
- Increased resistance to chloride and sulfides.
- Increased welding capacity.



Description	Gravity Feed Jar	
	Part #	Box Qty
1/4"-20 Channel Nut, No Spring	CNN025S6 ♡	100
3/8"-16 Channel Nut, No Spring	CNN037S6 ♡	100
1/2"-13 Channel Nut, No Spring	CNN050S6 ♡	100
1/2"-13 Thick Channel Nut	CNNT050S6 ♡	100
1/4"-20 Channel Nut	SN025S6 ♡	100
3/8"-16 Thick Channel Nut	SNT037S6 ♡	100
1/2"-13 Channel Nut, with Regular Spring	SN050S6 ♡	100
1/2"-13 Thick Channel Nut, with Regular Spring	SNT050S6 ♡	100
Beam Clamp to Strut with U-Bolt for 1 3/16" & 1 5/8" Channel	BCSU162S6 ★ ♡	25
Beam Clamp to Strut with U-Bolt for 2 7/16" & 3 1/4" Channel	BCSU325S6 ★ ♡	25
1/4" Square Washer	SW025S6 ★ ♡	100
3/8" Square Washer	SW037S6 ★ ♡	100
1/2" Square Washer	SW050S6 ★ ♡	100
5/8" Square Washer	SW062S6 ★ ♡	100
3/4" Square Washer	SW075S6 ★ ♡	100
4-Hole Splice Plate	SP4HS6 ★ ♡	25
3-Hole Corner Plate	CP3HS6 ★ ♡	25
4-Hole Tee Plate	TP4HS6 ★ ♡	20
5-Hole Cross Plate	XP5HS6 ★ ♡	15
2-Hole Corner Angle	CA2HS6 ★ ♡	50
4-Hole Corner Angle	CA4HS6 ★ ♡	25
2-Hole Cross Corner Angle	CAX2HS6 ★ ♡	50
3-Hole Long Corner Angle	CA3HLS6 ★ ♡	25
3-Hole 3-Way Corner Angle	CA3H3WS6 ★ ♡	25

★ Made in USA

♡ Harsh Environment Product

STAINLESS STEEL

STRUT ACCESSORIES: TYPE 316

- Expansive line of Stainless Steel fittings, clamps and hardware for strut systems.
- Increased resistance to chloride and sulfides.
- Increased welding capacity.

Description	Gravity Feed Jar	
	Part #	Box Qty
4-Hole 3-Way Corner Angle, Type 316 Stainless Steel	CA4H3WS6 ★ ♡	25
2-Hole Open 45 Degree Corner Angle, Type 316 Stainless Steel	CA02H45S6 ★ ♡	25
2-Hole Closed 45 Degree Corner Angle, Type 316 Stainless Steel	CAC2H45S6 ★ ♡	25
Post Base Single Channel, 2-Hole Square 3½", Type 316 Stainless Steel	PBS2H350QS6 ★ ♡	5
Post Base Single Channel, 2-Hole Square Flush 3½", Type 316 Stainless Steel	PBS2H350FLS6 ★ ♡	5
Post Base Single Channel, 4-Hole Standard 1⅝", Type 316 Stainless Steel	PBS4H162S6 ★ ♡	5
Post Base Single Channel, 4-Hole Standard 3½", Type 316 Stainless Steel	PBS4H350S6 ★ ♡	5
Post Base Single Channel, 4-Hole Square 3½", Type 316 Stainless Steel	PBS4H350QS6 ★ ♡	5
Post Base Double Channel, 4-Hole Standard 3½", Type 316 Stainless Steel	PBD4H350S6 ★ ♡	5
Post Base Double Channel, 4-Hole Square 3½", Type 316 Stainless Steel	PBD4H350QS6 ★ ♡	5
Conduit Strut Clamp, Fits ½" Rigid, Type 316 Stainless Steel	CCR050S6 ★ ♡	100
Conduit Strut Clamp, Fits ¾" Rigid, Type 316 Stainless Steel	CCR075S6 ★ ♡	100
Conduit Strut Clamp, Fits 1" Rigid, Type 316 Stainless Steel	CCR100S6 ★ ♡	100
Conduit Strut Clamp, Fits 1¼" Rigid, Type 316 Stainless Steel	CCR125S6 ★ ♡	50
Conduit Strut Clamp, Fits 1½" Rigid, Type 316 Stainless Steel	CCR150S6 ★ ♡	50
Conduit Strut Clamp, Fits 2" Rigid, Type 316 Stainless Steel	CCR200S6 ★ ♡	50
Conduit Strut Clamp, Fits 2½" Rigid, Type 316 Stainless Steel	CCR250S6 ★ ♡	50
Conduit Strut Clamp, Fits 3" Rigid, Type 316 Stainless Steel	CCR300S6 ★ ♡	25
Conduit Strut Clamp, Fits 3½" Rigid, Type 316 Stainless Steel	CCR350S6 ★ ♡	25
Conduit Strut Clamp, Fits 4" Rigid, Type 316 Stainless Steel	CCR400S6 ★ ♡	25
Conduit Strut Clamp, Fits 5" Rigid, Type 316 Stainless Steel	CCR500S6 ★ ♡	25
Conduit Strut Clamp, Fits 6" Rigid, Type 316 Stainless Steel	CCR600S6 ★ ♡	25
Conduit Strut Clamp, Fits 8" Rigid, Type 316 Stainless Steel	CCR800S6 ★ ♡	25
Wing Fitting Corner Connector, 8-Hole Opposed, Type 316 Stainless Steel	WFO8HS6 ★ ♡	10
Z-Fitting Cross 2-Hole, 1⅝" Channel, Type 316 Stainless Steel	FZX2H162S6 ♡	25



STAINLESS STEEL

★ Made in USA

♡ Harsh Environment Product

HEX NUTS: TYPE 18-8



- Most common designation for non-magnetic Stainless Steel fasteners.

	Gravity Feed Jar		
Size	Part #	Jar Qty	Master Carton
6-32	70105J	100	1200
8-32	70110J	100	1200
10-24	70115J	100	1200
10-32	70120J	100	1200
1/4"-20	70125J	100	1200
5/16"-18	70130J	100	1200
3/8"-16	70135J	100	600
7/16"-14	70137J	100	600
1/2"-13	70140J	100	600
5/8"-11	70145J	50	300
3/4"-10	70150J	50	300

Harsh Environment Product

HEX NUTS: TYPE 316



- Increased resistance to chloride and sulfides.
- Increased welding capacity.

	Gravity Feed Jar		
Size	Part #	Jar Qty	Master Carton
6-32	70105SS316J	100	1200
8-32	70110SS316J	100	1200
10-24	70115SS316J	100	1200
10-32	70120SS316J	100	1200
1/4"-20	70125SS316J	100	1200
5/16"-18	70130SS316J	100	1200
3/8"-16	70135SS316J	100	600
7/16"-14	70137SS316J	100	600
1/2"-13	70140SS316J	100	600
5/8"-11	70145SS316J	50	600
3/4"-10	70150SS316J	50	600

Harsh Environment Product

STAINLESS STEEL

SERRATED FLANGE HEX NUTS: TYPE 18-8

- Flange whiz nuts are machine-threaded hex nuts with a serrated flange, designed to prevent loosening.
- Most common designation for non-magnetic stainless steel fasteners.



	Gravity Feed Jar		
Size	Part #	Jar Qty	Master Carton
6-32	70205J	100	1200
8-32	70210J	100	1200
10-24	70215J	100	1200
10-32	70220J	100	1200
¼"-20	70225J	100	1200
⅝"-18	70230J	100	1200
⅜"-16	70235J	100	600
½"-13	70240J	100	600

Harsh Environment Product

NYLOCK HEX NUTS: TYPE 18-8

- Machine-threaded nuts have a nylon-filled collar to prevent loosening.
- Most common designation for non-magnetic stainless steel fasteners.

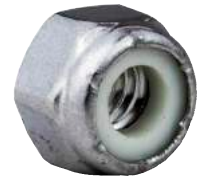

	Gravity Feed Jar		
Size	Part #	Jar Qty	Master Carton
6-32	70405J	100	1200
8-32	70410J	100	1200
10-24	70415J	100	1200
10-32	70420J	100	1200
¼-20	70425J	100	1200
⅝-18	70430J	100	1200
⅜-16	70435J	100	600
½-13	70440J	100	600
⅝-11	70445J	50	300
¾-10	70450J	50	300

Harsh Environment Product

FLAT CUT WASHERS: TYPE 18-8



- Most common type of washer.
- Most common designation for non-magnetic stainless steel fasteners.

	Gravity Feed Jar		
Size	Part #	Jar Qty	Master Carton
#6	70305J	100	1200
#8	70310J	100	1200
#10	70315J	100	1200
1/4"	70325J	100	1200
5/16"	70330J	100	1200
3/8"	70335J	100	1200
7/16"	70337J	100	600
1/2"	70340J	100	600
5/8"	70345J	100	600
3/4"	70350J	100	600

Harsh Environment Product

FLAT CUT WASHERS: TYPE 316



- Most common type of washer.
- Increased resistance to chloride and sulfides.
- Increased welding capacity.

	Gravity Feed Jar		
Size	Part #	Jar Qty	Master Carton
#6	70305SS316J	100	1200
#8	70310SS316J	100	1200
#10	70315SS316J	100	1200
1/4"	70325SS316J	100	1200
5/16"	70330SS316J	100	1200
3/8"	70335SS316J	100	1200
7/16"	70337SS316J	100	600
1/2"	70340SS316J	100	600
5/8"	70345SS316J	100	600
3/4"	70350SS316J	100	600

Harsh Environment Product

LOCK WASHERS: TYPE 18-8

Size	Part #	Jar Qty	Master Carton
Medium Split			
#6	70505J	100	1200
#8	70510J	100	1200
#10	70515J	100	1200
1/4"	70525J	100	1200
5/16"	70530J	100	1200
3/8"	70535J	100	1200
7/16"	70537J	100	600
1/2"	70540J	100	600
5/8"	70545J	100	600
3/4"	70550J	100	600



Harsh Environment Product

LOCK WASHERS: TYPE 316

Size	Part #	Jar Qty	Master Carton
Medium Split			
#6	70505SS316J	100	1200
#8	70510SS316J	100	1200
#10	70515SS316J	100	1200
1/4"	70525SS316J	100	1200
5/16"	70530SS316J	100	1200
3/8"	70535SS316J	100	1200
7/16"	70537SS316J	100	600
1/2"	70540SS316J	100	600
5/8"	70545SS316J	100	600
3/4"	70550SS316J	100	600



Harsh Environment Product

EXTERNAL TEETH LOCK WASHERS: TYPE 18-8

Size	Part #	Jar Qty	Master Carton
Medium Split			
#6	70906J	100	1200
#8	70911J	100	1200
#10	70916J	100	1200
1/4"	70925J	100	1200
5/16"	70935J	100	1200
3/8"	70941J	100	600



Harsh Environment Product

- Used to prevent loosening or turning through a “lock” mechanism.
- Useful in applications prone to vibrations.

FENDER WASHERS: TYPE 18-8



Harsh Environment Product

- Flat washers with a large outer diameter in proportion to its central hole.

	Gravity Feed Jar		
Size	Part #	Jar Qty	Master Carton
3/16 x 1"	70709J	100	1200
3/16 x 1 1/4"	70710J	100	1200
1/4 x 1"	70720J	100	1200
1/4 x 1 1/4"	70725J	100	600
1/4 x 1 1/2"	70730J	100	600
1/4 x 2"	70735J	100	600
5/16 x 1 1/4"	70733J	100	600
5/16 x 1 1/2"	70740J	100	600
3/8 x 1"	70741J	100	1200
3/8 x 1 1/4"	70743J	100	600
3/8 x 1 1/2"	70745J	100	600
3/8 x 2"	70746J	100	600
1/2 x 1 3/8"	70749J	100	600
1/2 x 1 1/2"	70750J	100	600
1/2 x 2"	70755J	100	600

FENDER WASHERS: TYPE 316



Harsh Environment Product

- More surface area to spread the load on wood or lighter gauge sheet metal.
- Reduces the likelihood of sacrificing the fastened material.

	Gravity Feed Jar		
Size	Part #	Jar Qty	Master Carton
3/16 x 1"	70709SS316J	100	600
1/4 x 1"	70720SS316J	100	1200
1/4 x 1 1/4"	70725SS316J	100	600
1/4 x 1 1/2"	70730SS316J	100	600
1/4 x 2"	70733SS316J	100	600
5/16 x 1 1/4"	70735SS316J	100	600
5/16 x 1 1/2"	70740SS316J	100	600
3/8 x 1 1/4"	70743SS316J	100	600
3/8 x 1 1/2"	70745SS316J	100	600
3/8 x 2"	70746SS316J	100	600
1/2 x 1 1/2"	70750SS316J	100	600
1/2 x 2"	70755SS316J	100	600

STAINLESS STEEL

BELLEVILLE WASHERS: TYPE 18-8

- Flat on one side and conical-shaped on the other where the machine screw or hex head bolt makes contact.



	Gravity Feed Jar		
Size	Part #	Jar Qty	Master Carton
1/4"	40905SSJ	100	1200
5/16"	40910SSJ	100	1200
3/8"	40915SSJ	100	1200
1/2"	40925SSJ	100	600

Harsh Environment Product

FINISH CUP WASHERS: TYPE 18-8

- Designed for use with flat or oval head screws.
- Eliminate the need for a countersunk hole and provide a clean appearance.



	Gravity Feed Jar		
Size	Part #	Jar Qty	Master Carton
#6	71105J	100	1200
#8	71110J	100	1200
#10	71115J	100	1200
#12	71120J	100	1200
1/4"	71125J	100	1200
3/8"	71135J	100	1200

Harsh Environment Product

HEX HEAD CAP SCREWS (BOLTS): TYPE 18-8



- Hexagonal shaped-head with machine thread.

Size	Part #	Gravity Feed Jar	
		Jar Qty	Master Carton
1/4-20 x 3/8"***	74206J ♡	100	1200
1/4-20 x 1/2"***	74208J ♡	100	1200
1/4-20 x 5/8"***	74210J ♡	100	600
1/4-20 x 3/4"***	74212J ♡	100	600
1/4-20 x 1"***	74216J ♡	100	600
1/4-20 x 1 1/4"	74220J ♡	100	600
1/4-20 x 1 1/2"	74224J ♡	100	600
1/4-20 x 2"	74232J ♡	100	600
1/4-20 x 2 1/4"	74236J ♡	100	600
1/4-20 x 2 1/2"	74240J ♡	100	600
1/4-20 x 3"	74248J ♡	100	600
5/16-18 x 1/2"***	74308J ♡	100	600
5/16-18 x 3/4"***	74312J ♡	100	600
5/16-18 x 1"***	74316J ♡	100	600
5/16-18 x 1 1/4"	74320J ♡	100	600
5/16-18 x 1 1/2"	74324J ♡	100	600
5/16-18 x 1 3/4"	74328J ♡	100	600
5/16-18 x 2"	74332J ♡	100	600
5/16-18 x 2 1/2"	74340J ♡	100	600
5/16-18 x 3"	74348J ♡	100	600
5/16-18 x 3 1/2"	74356J ♡	50	300
3/8-16 x 1/2"***	74408J ♡	100	600
3/8-16 x 3/4"***	74412J ♡	100	600
3/8-16 x 7/8"***	74414J ♡	100	600
3/8-16 x 1"***	74416J ♡	100	600
3/8-16 x 1 1/4"	74420J ♡	100	600
3/8-16 x 1 1/2"	74424J ♡	100	600
3/8-16 x 2"	74432J ♡	100	600
3/8-16 x 2 1/2"	74440J ♡	50	300
3/8-16 x 3"	74448J ♡	50	300
3/8-16 x 3 1/2"	74456J ♡	50	300
3/8-16 x 4"	74464J ♡	50	300

*These items are packaged in a cardboard box.

**These sizes are fully threaded.

♡ Harsh Environment Product

Continued on next page.

STAINLESS STEEL

HEX HEAD CAP SCREWS (BOLTS): TYPE 18-8 (CONT.)

- Hexagonal shaped-head with machine thread.



Size	Gravity Feed Jar		
	Part #	Jar Qty	Master Carton
3/8-16 x 5"	74480* ♡	50	50
3/8-16 x 6"	74496* ♡	25	25
1/2-13 x 3/4"***	74612J ♡	50	300
1/2-13 x 1"***	74616J ♡	50	300
1/2-13 x 1 1/4"***	74620J ♡	50	300
1/2-13 x 1 1/2"	74624J ♡	50	300
1/2-13 x 1 3/4"	74628J ♡	50	300
1/2-13 x 2"	74632J ♡	50	300
1/2-13 x 2-1/4"	74636J ♡	50	300
1/2-13 x 2-1/2"	74640J ♡	50	300
1/2-13 x 3"	74648J ♡	50	300
1/2-13 x 3 1/4"	74652J ♡	25	150
1/2-13 x 3 1/2"	74656J ♡	25	150
1/2-13 x 4"	74664J ♡	25	150
1/2-13 x 4 1/2"	74672J ♡	25	150
1/2-13 x 5"	74680J ♡	25	150
1/2-13 x 5 1/2"	74688* ♡	25	25
5/8-11 x 1"***	74816* ♡	50	300
5/8-11 x 1 1/4"***	74820* ♡	50	300
5/8-11 x 1 1/2"***	74824* ♡	50	300
5/8-11 x 2"	74832J ♡	25	150
5/8-11 x 2 1/2"	74840J ♡	25	150
5/8-11 x 3"	74848J ♡	25	150
5/8-11 x 3 1/2"	74856* ♡	25	25
5/8-11 x 4"	74864* ♡	25	25
5/8-11 x 6"	74896* ♡	25	25
3/4-10 x 1"***	75016J ♡	50	300
3/4-10 x 1 1/2"***	75024J ♡	50	300
3/4-10 x 2"	75032J ♡	25	150
3/4-10 x 2 1/2"	75040J ♡	25	150
3/4-10 x 3"	75048* ♡	25	25
3/4-10 x 3 1/2"	75056* ♡	25	25

*These items are packaged in a cardboard box.

**These sizes are fully threaded.

♡ Harsh Environment Product

HEX HEAD CAP SCREWS (BOLTS): TYPE 316



- Hexagonal shaped-head with machine thread.

Size	Part #	Gravity Feed Jar	
		Jar Qty	Master Carton
1/4-20 x 1/2"***	74208SS316J ♡	100	1200
1/4-20 x 5/8"***	74210SS316J ♡	100	600
1/4-20 x 3/4"***	74212SS316J ♡	100	600
1/4-20 x 1"***	74216SS316J ♡	100	600
1/4-20 x 1 1/4"	74220SS316J ♡	100	600
1/4-20 x 1 1/2"	74224SS316J ♡	100	600
1/4-20 x 2"	74232SS316J ♡	100	600
1/4-20 x 2 1/4"	74236SS316J ♡	100	600
1/4-20 x 2 1/2"	74240SS316J ♡	100	600
1/4-20 x 3"	74248SS316J ♡	100	600
5/16-18 x 1/2"***	74308SS316J ♡	100	600
5/16-18 x 3/4"***	74312SS316J ♡	100	600
5/16-18 x 1"***	74316SS316J ♡	100	600
5/16-18 x 1 1/4"	74320SS316J ♡	100	600
5/16-18 x 1 1/2"	74324SS316J ♡	100	600
5/16-18 x 1 3/4"	74328SS316J ♡	100	600
5/16-18 x 2"	74332SS316J ♡	100	600
5/16-18 x 2 1/2"	74340SS316J ♡	100	600
5/16-18 x 3"	74348SS316J ♡	100	600
5/16-18 x 3 1/2"	74356SS316J ♡	50	300
3/8-16 x 1/2"***	74408SS316J ♡	100	600
3/8-16 x 3/4"***	74412SS316J ♡	100	600
3/8-16 x 7/8"***	74414SS316J ♡	100	600
3/8-16 x 1"***	74416SS316J ♡	100	600
3/8-16 x 1 1/4"	74420SS316J ♡	100	600
3/8-16 x 1 1/2"	74424SS316J ♡	100	600
3/8-16 x 2"	74432SS316J ♡	100	600
3/8-16 x 2 1/2"	74440SS316J ♡	50	300
3/8-16 x 3"	74448SS316J ♡	50	300
3/8-16 x 3 1/2"	74456SS316J ♡	50	300
3/8-16 x 4"	74464SS316J ♡	50	300
3/8-16 x 5"	74480SS316J ♡	50	300

*These items are packaged in a cardboard box.

**These sizes are fully threaded.

♡ Harsh Environment Product

Continued on next page.

STAINLESS STEEL

HEX HEAD CAP SCREWS (BOLTS): TYPE 316 (CONT.)

- Hexagonal shaped-head with machine thread.



Size	Gravity Feed Jar		
	Part #	Jar Qty	Master Carton
3/8-16 x 6"	74496SS316* ♡	25	25
1/2-13 x 3/4" **	74612SS316J ♡	50	300
1/2-13 x 1" **	74616SS316J ♡	50	300
1/2-13 x 1 1/4" **	74620SS316J ♡	50	300
1/2-13 x 1 1/2"	74624SS316J ♡	50	300
1/2-13 x 1 3/4"	74628SS316J ♡	50	300
1/2-13 x 2"	74632SS316J ♡	50	300
1/2-13 x 2 1/4"	74636SS316J ♡	50	300
1/2-13 x 2 1/2"	74640SS316J ♡	50	300
1/2-13 x 3"	74648SS316J ♡	50	300
1/2-13 x 3 1/4"	74652SS316J ♡	25	150
1/2-13 x 3 1/2"	74656SS316J ♡	25	150
1/2-13 x 4"	74664SS316J ♡	25	150
1/2-13 x 4 1/2"	74672SS316J ♡	25	150
1/2-13 x 5"	74680SS316J ♡	25	150
1/2-13 x 5 1/2"	74688SS316* ♡	25	150
5/8-11 x 1" **	74816SS316J ♡	50	300
5/8-11 x 1 1/4" **	74820SS316J ♡	50	300
5/8-11 x 1 1/2" **	74824SS316J ♡	50	300
5/8-11 x 2"	74832SS316J ♡	25	150
5/8-11 x 2 1/2"	74840SS316J ♡	25	150
5/8-11 x 3"	74848SS316J ♡	25	150
5/8-11 x 3 1/2"	74856SS316* ♡	25	25
5/8-11 x 4"	74864SS316* ♡	25	25
5/8-11 x 6"	74896SS316* ♡	25	25
3/4-10 x 1" **	75016SS316J ♡	50	300
3/4-10 x 1 1/2" **	75024SS316J ♡	50	300
3/4-10 x 2"	75032SS316J ♡	25	150
3/4-10 x 2 1/2"	75040SS316J ♡	25	150
3/4-10 x 3"	75048SS316* ♡	25	25
3/4-10 x 3 1/2"	75056SS316* ♡	25	25

*These items are packaged in a cardboard box.

**These sizes are fully threaded.

































♡ Harsh Environment Product

HEX HEAD TAP BOLTS: TYPE 18-8



- Hexagonal shaped-head with machine thread.
- Designed to be inserted through holes and tightened by torquing a nut, or mated with an internally threaded hole.
- Fully threaded

 Harsh Environment Product

Size	Part #	Gravity Feed Jar	
		Jar Qty	Master Carton
1/4-20 x 3/8"	74206J 	100	1200
1/4-20 x 1/2"	74208J 	100	1200
1/4-20 x 5/8"	74210J 	100	600
1/4-20 x 3/4"	74212J 	100	600
1/4-20 x 1"	74216J 	100	600
1/4-20 x 1 1/4"	74222J 	100	600
1/4-20 x 1 1/2"	74226J 	100	600
1/4-20 x 2"	74234J 	100	600
1/4-20 x 2 1/4"	74238J 	100	600
1/4-20 x 2 1/2"	74242J 	100	600
1/4-20 x 3"	74250J 	100	600
5/16-18 x 1/2"	74308J 	100	600
5/16-18 x 3/4"	74312J 	100	600
5/16-18 x 1"	74316J 	100	600
5/16-18 x 1 1/4"	74322J 	100	600
5/16-18 x 1 1/2"	74326J 	100	600
5/16-18 x 1 3/4"	74330J 	100	600
5/16-18 x 2"	74334J 	100	600
5/16-18 x 2 1/2"	74342J 	100	600
5/16-18 x 3"	74350 	100	600
5/16-18 x 3 1/2"	74358J 	50	300
3/8-16 x 1/2"	74408J 	100	600
3/8-16 x 3/4"	74412J 	100	600
3/8-16 x 7/8"	74414J 	100	600
3/8-16 x 1"	74416J 	100	600
3/8-16 x 1 1/4"	74422J 	100	600
3/8-16 x 1 1/2"	74426J 	100	600
3/8-16 x 2"	74434J 	100	600
3/8-16 x 2 1/2"	74442J 	50	300
3/8-16 x 3"	74450J 	50	300
3/8-16 x 3 1/2"	74458J 	50	300
3/8-16 x 4"	74466J 	50	300

STAINLESS STEEL

































HEX HEAD TAP BOLTS: TYPE 18-8

- Hexagonal shaped-head with machine thread.
- Designed to be inserted through holes and tightened by torquing a nut, or mated with an internally threaded hole.
- Fully threaded.



 Harsh Environment Product

*These items are packaged in a cardboard box.

































	 Gravity Feed Jar		
Size	Part #	Jar Qty	Master Carton
3/8-16 x 5"	74482J 	50	300
3/8-16 x 6"	74498* 	25	25
1/2-13 x 3/4"	74612J 	50	300
1/2-13 x 1"	74616J 	50	300
1/2-13 x 1 1/4"	74620J 	50	300
1/2-13 x 1 1/2"	74626J 	50	300
1/2-13 x 1 3/4"	74630J 	50	300
1/2-13 x 2"	74634J 	50	300
1/2-13 x 2 1/4"	74638J 	50	300
1/2-13 x 2 1/2"	74642J 	50	300
1/2-13 x 3"	74650J 	50	300
1/2-13 x 3 1/4"	74654J 	25	150
1/2-13 x 3 1/2"	74658J 	25	150
1/2-13 x 4"	74666J 	25	150
1/2-13 x 4 1/2"	74674J 	25	150
1/2-13 x 5"	74682J 	25	150
1/2-13 x 5 1/2"	74690* 	25	25
5/8-11 x 1"	74816J 	50	300
5/8-11 x 1 1/4"	74820J 	50	300
5/8-11 x 1 1/2"	74824J 	50	300
5/8-11 x 2"	74834J 	25	150
5/8-11 x 2 1/2"	74842J 	25	150
5/8-11 x 3"	74850J 	25	150
5/8-11 x 3 1/2"	74858* 	25	25
5/8-11 x 4"	74866* 	25	25
5/8-11 x 6"	74898* 	25	25
3/4-10 x 1"	75016J 	50	300
3/4-10 x 1 1/2"	75024J 	50	300
3/4-10 x 2"	75034J 	25	150
3/4-10 x 2 1/2"	75042J 	25	150
3/4-10 x 3"	75050* 	25	25
3/4-10 x 3 1/2"	75058* 	25	25

HEX HEAD TAP BOLTS: TYPE 316



- Hexagonal shaped-head with machine thread.
- Designed to be inserted through holes and tightened by torquing a nut, or mated with an internally threaded hole.
- Fully threaded.

 Harsh Environment Product

Size	Gravity Feed Jar		
	Part #	Jar Qty	Master Carton
1/4-20 x 1/2"	74208SS316J 	100	1200
1/4-20 x 5/8"	74210SS316J 	100	600
1/4-20 x 3/4"	74212SS316J 	100	600
1/4-20 x 1"	74216SS316J 	100	600
1/4-20 x 1 1/4"	74222SS316J 	100	600
1/4-20 x 1 1/2"	74226SS316J 	100	600
1/4-20 x 2"	74234SS316J 	100	600
1/4-20 x 2 1/4"	74238SS316J 	100	600
1/4-20 x 2 1/2"	74242SS316J 	100	600
1/4-20 x 3"	74250SS316J 	100	600
1/4-20 x 4"	74266SS316J 	50	300
1/4-20 x 5"	74282SS316J 	50	300
5/16-18 x 1/2"	74308SS316J 	100	600
5/16-18 x 3/4"	74312SS316J 	100	600
5/16-18 x 1"	74316SS316J 	100	600
5/16-18 x 1 1/4"	74322SS316J 	100	600
5/16-18 x 1 1/2"	74326SS316J 	100	600
5/16-18 x 1 3/4"	74330SS316J 	100	600
5/16-18 x 2"	74334SS316J 	100	600
5/16-18 x 2 1/2"	74342SS316J 	100	600
5/16-18 x 3"	74350SS316J 	100	600
5/16-18 x 3 1/2"	74358SS316J 	50	300
3/8-16 x 1/2"	74408SS316J 	100	600
3/8-16 x 3/4"	74412SS316J 	100	600
3/8-16 x 7/8"	74414SS316J 	100	600
3/8-16 x 1"	74416SS316J 	100	600
3/8-16 x 1 1/4"	74422SS316J 	100	600
3/8-16 x 1 1/2"	74426SS316J 	100	600
3/8-16 x 2"	74434SS316J 	50	300
3/8-16 x 2 1/2"	74442SS316J 	50	300
3/8-16 x 3"	74450SS316J 	50	300
3/8-16 x 3 1/2"	74458SS316J 	50	300

STAINLESS STEEL

HEX HEAD TAP BOLTS: TYPE 316

- Hexagonal shaped-head with machine thread.
- Designed to be inserted through holes and tightened by torquing a nut, or mated with an internally threaded hole.
- Fully threaded.



Gravity Feed Jar			
Description	Part #	Jar Qty	Master Carton
3/8-16 x 4"	74466SS316J	50	300
3/8-16 x 5"	74482SS316J	50	300
3/8-16 x 6"	74498SS316*	25	25
1/2-13 x 3/4"	74612SS316J	50	300
1/2-13 x 1"	74616SS316J	50	300
1/2-13 x 1 1/4"	74620SS316J	50	300
1/2-13 x 1 1/2"	74626SS316J	50	300
1/2-13 x 1 3/4"	74630SS316J	50	300
1/2-13 x 2"	74634SS316J	50	300
1/2-13 x 2 1/4"	74638SS316J	50	300
1/2-13 x 2 1/2"	74642SS316J	50	300
1/2-13 x 3"	74650SS316J	50	300
1/2-13 x 3 1/2"	74658SS316J	25	150
1/2-13 x 4"	74666SS316J	25	150
1/2-13 x 4 1/2"	74674SS316J	25	150
1/2-13 x 5"	74682SS316J	25	150
1/2-13 x 5 1/2"	74690SS316*	25	25
5/8-11 x 1"	74816SS316J	50	300
5/8-11 x 1 1/4"	74820SS316J	50	300
5/8-11 x 1 1/2"	74824SS316J	50	300
5/8-11 x 2"	74834SS316J	25	150
5/8-11 x 2 1/2"	74842SS316J	25	150
5/8-11 x 3"	74850SS316J	25	150
5/8-11 x 3 1/2"	74858SS316*	25	25
5/8-11 x 4"	74866SS316*	25	25
5/8-11 x 6"	74898SS316*	25	25
3/4-10 x 1"	75016SS316J	50	300
3/4-10 x 1 1/2"	75024SS316J	50	300
3/4-10 x 2"	75034SS316J	25	150
3/4-10 x 2 1/2"	75042SS316J	25	150
3/4-10 x 3"	75050SS316*	25	25
3/4-10 x 3 1/2"	75058SS316*	25	25

Harsh Environment Product

*These items are packaged in a cardboard box.

HEX HEAD LAG BOLTS: TYPE 18-8



- For heavier load applications.

	Gravity Feed Jar		
Size	Part #	Jar Qty	Master Carton
1/4 x 1 1/2"	74924J	100	600
1/4 x 2"	74932J	100	600
1/4 x 3"	74948J	100	600
5/16 x 1 1/2"	75124J	100	600
5/16 x 2"	75132J	100	600
5/16 x 3"	75148J	50	300
5/16 x 3 1/2"	75156J	50	300
5/16 x 4"	75164J	50	300
5/16 x 4 1/2"	75172J	50	300
5/16 x 5"	75180J	50	300
3/8 x 1 1/4"	75220J	100	600
3/8 x 1 1/2"	75224J	100	600
3/8 x 2"	75232J	50	300
3/8 x 3"	75248J	50	300
3/8 x 4"	75264J	50	300
1/2 x 2"	75332J	50	300
1/2 x 3"	75348J	50	300
1/2 x 4"	75364J	25	150

Harsh Environment Product

CARRIAGE BOLTS: TYPE 18-8



- Primarily used in wood applications.
- Square neck prevents the head from turning when tightened in wood applications.













	Gravity Feed Jar		
Size	Part #	Jar Qty	Master Carton
1/4-20 x 1 1/2"	76108J	100	1200
1/4-20 x 3/4"	76112J	100	600
1/4-20 x 1"	76116J	100	600
1/4-20 x 2 1/2"	76140J	100	600
5/16-18 x 1 1/2"	76224J	100	600
3/8-16 x 3/4"	76312J	100	600
3/8-16 x 1 1/2"	76324J	100	600
3/8-16 x 2"	76332J	100	600
3/8-16 x 3"	76348J	50	300
1/2-13 x 1 1/2"	76424J	50	300

Harsh Environment Product

STAINLESS STEEL

SLEEVE ANCHOR - HEX NUT: TYPE 304

- Designed for use in brick, cinder block, thin wall and solid concrete.
- Removable after installation.







				 Gravity Feed Jar		
Size	Drill Bit Diameter	Min. Embedment	Nut Type	Part #	Jar Qty	Master Carton
1/4 x 1 3/8"	1/4"	1 1/8"	Acorn	61413SSJ 	100	600
1/4 x 2 1/4"	1/4"	1 1/8"	Acorn	61422SSJ 	100	600
5/16 x 1 1/2"	5/16"	1 3/16"	Hex	61513SSJ 	100	600
5/16 x 2 1/2"	5/16"	1 3/16"	Hex	61522SSJ 	100	600
3/8 x 1 7/8"	3/8"	1 1/4"	Hex	61617SSJ 	50	300
3/8 x 3"	3/8"	1 1/4"	Hex	61630SSJ 	50	300
3/8 x 4"	3/8"	1 1/4"	Hex	61640SSJ 	50	300
1/2 x 2 1/4"	1/2"	1 1/2"	Hex	61822SSJ 	25	150
1/2 x 3"	1/2"	1 1/2"	Hex	61830SSJ 	25	150
1/2 x 4"	1/2"	1 1/2"	Hex	61840SSJ 	25	150
5/8 x 4 1/4"	5/8"	2"	Hex	61942SSJ 	10	60



 Harsh Environment Product

SLEEVE ANCHOR - FLAT HEAD: TYPE 304

- Medium-duty, versatile anchor.
- Removable after installation.

			 Gravity Feed Jar		
Size	Drill Bit Diameter	Anchor Length	Part #	Jar Qty	Master Carton
1/4" x 2"	1/4"	1 1/8"	61421SSJ 	100	600
1/4" x 3"	1/4"	1 1/8"	61431SSJ 	100	600
3/8 x 3"	3/8"	1 1/4"	61631SSJ 	50	300
3/8 x 4"	3/8"	1 1/4"	61641SSJ 	50	300
3/8 x 5"	3/8"	1 1/4"	61651SSJ 	50	300
3/8 x 6"	3/8"	1 1/4"	61661SS* 	50	50



STAINLESS STEEL

*These items are packaged in a cardboard box

 Harsh Environment Product

DROP-IN ANCHORS - STANDARD: TYPE 304



- Machine-threaded expansion anchors for use in solid concrete, hard stone, and solid block.

			Gravity Feed Jar		
Size	Drill Bit Diameter	Anchor Length	Part #	Jar Qty	Master Carton
1/4" - 20	3/8"	1"	60402SSJ	100	600
3/8" - 16	1/2"	1 5/8"	60404SSJ	50	300
1/2" - 13	5/8"	2"	60406SSJ	50	300
5/8" - 11	7/8"	2 1/2"	60408SS*	25	25
3/4" - 10	1"	3 1/4"	60410SS*	25	25

Harsh Environment Product

*These items are packaged in a cardboard box.

DROP-IN ANCHORS - STANDARD: TYPE 316



- Machine-threaded expansion anchors for use in solid concrete, hard stone, and solid block.

			Gravity Feed Jar		
Size	Drill Bit Diameter	Anchor Length	Part #	Jar Qty	Master Carton
1/4" - 20	3/8"	1"	60402SS316J	100	600
3/8" - 16	1/2"	1 5/8"	60404SS316J	50	300
1/2" - 13	5/8"	2"	60406SS316J	50	300
5/8" - 11	7/8"	2 1/2"	60408SS316*	25	25
3/4" - 10	1"	3 1/4"	60410SS316*	25	25

Harsh Environment Product

STAINLESS STEEL

WEDGE ANCHOR: TYPE 304

- Used in concrete and stone applications.

			Gravity Feed Jar		
Size	Drill Bit Diameter	Thread Length	Part #	Jar Qty	Master Carton
1/4-20 x 1 3/4"	1/4"	3/4"	76528J	100	600
1/4-20 x 2 1/4"	1/4"	1 1/4"	76536J	100	600
1/4-20 x 3 1/4"	1/4"	2 1/4"	76552J	100	600
3/8-16 x 2 1/4"	3/8"	1 1/8"	76736J	50	300
3/8-16 x 3"	3/8"	1 3/4"	76748J	50	300
3/8-16 x 3 3/4"	3/8"	2 1/2"	76760J	50	300
3/8-16 x 5"	3/8"	3 3/4"	76780J	50	300
1/2-13 x 2 3/4"	1/2"	1 1/4"	76944J	25	150
1/2-13 x 3 3/4"	1/2"	2 1/4"	76960J	25	150
1/2-13 x 4 1/4"	1/2"	2 3/4"	76968J	25	150
1/2-13 x 5 1/2"	1/2"	3"	76988*	25	25
1/2-13 x 7"	1/2"	3 1/2"	76998*	25	25
5/8-11 x 3 1/2"	5/8"	1 3/4"	77156J	10	60
5/8-11 x 4 1/4"	5/8"	2 1/2"	77166J	10	60
5/8-11 x 5"	5/8"	3 1/4"	77180J	10	60
5/8-11 x 6"	5/8"	4 1/4"	77196*	10	10



Wedge Anchors are also called:

- Molly Bolts
- Red Heads
- Parabolts
- Kwikbolts
- Thunder Studs
- Stud Bolts

For U.S. made availability please contact customer service.

*These items are packaged in cardboard boxes.

Installation

1) Select a carbide drill bit with a diameter equal to the anchor diameter. Drill hole to any depth exceeding the desired embedment.

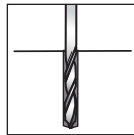

2) Clean hole or continue drilling additional depth to accommodate drill fines.

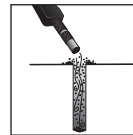

3) Assemble washer and nut, leaving nut flush with end of anchor to protect threads. Drive anchor through material to be fastened until washer is flush to surface of material.

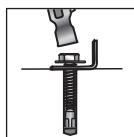



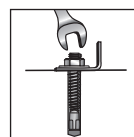



























4) Expand anchor by tightening nut 3-5 turns past the hand tight position.



ROUND HEAD MACHINE SCREWS - PHILLIPS: TYPE 18-8



- Used in existing or predrilled, pre-tapped holes.

Size	Part #	Gravity Feed Jar	
		Jar Qty	Master Carton
6-32 x 1/2"	52109SSJ 	100	1200
6-32 x 3/4"	52113SSJ 	100	1200
6-32 x 1"	52117SSJ 	100	1200
6-32 x 1 1/2"	52125SSJ 	100	1200
6-32 x 2"	52133SSJ 	100	600
8-32 x 1/2"	52309SSJ 	100	1200
8-32 x 3/4"	52313SSJ 	100	1200
8-32 x 1"	52317SSJ 	100	1200
8-32 x 1 1/2"	52325SSJ 	100	1200
8-32 x 2"	52333SSJ 	100	600
10-24 x 1/2"	52509SSJ 	100	1200
10-24 x 3/4"	52513SSJ 	100	1200
10-24 x 1"	52517SSJ 	100	1200
10-24 x 1 1/4"	52521SSJ 	100	1200
10-24 x 1 3/4"	52529SSJ 	100	600
10-32 x 1/2"	52709SSJ 	100	1200
10-32 x 3/4"	52713SSJ 	100	1200
10-32 x 1"	52717SSJ 	100	1200
10-32 x 1 1/2"	52725SSJ 	100	600
10-32 x 2"	52733SSJ 	100	600
1/4-20 x 1/2"	62908SSJ 	100	1200
1/4-20 x 3/4"	62911SSJ 	100	1200
1/4-20 x 1"	62915SSJ 	100	600
1/4-20 x 1 1/4"	62919SSJ 	100	600
1/4-20 x 1 1/2"	62923SSJ 	100	600
1/4-20 x 2"	62931SSJ 	100	600
3/8-16 x 3/4"	63013SSJ 	100	600
3/8-16 x 1"	63017SSJ 	100	600
3/8-16 x 1-1/2"	63025SSJ 	100	600
3/8-16 x 2"	63033SSJ 	100	600

 Harsh Environment Product

STAINLESS STEEL

ROUND HEAD MACHINE SCREWS - SLOTTED: TYPE 316

- Used in existing or predrilled, pre-tapped holes.

Size	Gravity Feed Jar		
	Part #	Jar Qty	Master Carton
6-32 x 1/2"	52108SS316J	100	1200
6-32 x 3/4"	52112SS316J	100	1200
6-32 x 1"	52116SS316J	100	1200
6-32 x 1 1/2"	52124SS316J	100	1200
6-32 x 2"	52132SS316J	100	600
8-32 x 1/2"	52308SS316J	100	1200
8-32 x 3/4"	52312SS316J	100	1200
8-32 x 1"	52316SS316J	100	1200
8-32 x 1 1/2"	52324SS316J	100	1200
8-32 x 2"	52332SS316J	100	600
10-24 x 1/2"	52508SS316J	100	1200
10-24 x 3/4"	52512SS316J	100	1200
10-24 x 1"	52516SS316J	100	1200
10-24 x 1 1/4"	52520SS316J	100	1200
10-24 x 1 3/4"	52528SS316J	100	600
10-32 x 1/2"	52708SS316J	100	1200
10-32 x 3/4"	52712SS316J	100	1200
10-32 x 1"	52716SS316J	100	1200
10-32 x 1 1/2"	52724SS316J	100	600
10-32 x 2"	52732SS316J	100	600
1/4-20 x 1/2"	52908SS316J	100	1200
1/4-20 x 3/4"	52912SS316J	100	1200
1/4-20 x 1"	52916SS316J	100	600
1/4-20 x 1 1/4"	52920SS316J	100	600
1/4-20 x 1 1/2"	52924SS316J	100	600
1/4-20 x 2"	52932SS316J	100	600
3/8-16 x 3/4"	53112SS316J	100	600
3/8-16 x 1"	53116SS316J	100	600
3/8-16 x 1 1/2"	53124SS316J	100	600
3/8-16 x 2"	53132SS316J	100	600







































Harsh Environment Product

PAN HEAD MACHINE SCREWS - PHILLIPS: TYPE 18-8































 Harsh Environment Product

Size	Part #	Gravity Feed Jar	
		Jar Qty	Master Carton
6-32 x 1/4"	62104SSJ 	100	1200
6-32 x 3/8"	62106SSJ 	100	1200
6-32 x 1/2"	62108SSJ 	100	1200
6-32 x 3/4"	62112SSJ 	100	1200
6-32 x 1"	62116SSJ 	100	1200
6-32 x 1 1/2"	62124SSJ 	100	1200
6-32 x 2"	62132SSJ 	100	600
8-32 x 1/2"	62308SSJ 	100	1200
8-32 x 3/4"	62312SSJ 	100	1200
8-32 x 1"	62316SSJ 	100	1200
8-32 x 1 1/2"	62324SSJ 	100	1200
8-32 x 2"	62332SSJ 	100	600
10-24 x 1/2"	62508SSJ 	100	1200
10-24 x 3/4"	62512SSJ 	100	1200
10-24 x 1"	62516SSJ 	100	1200
10-24 x 1 1/4"	62520SSJ 	100	1200
10-24 x 1 1/2"	62524SSJ 	100	600
10-24 x 1 3/4"	62528SSJ 	100	600
10-32 x 1/2"	62708SSJ 	100	1200
10-32 x 3/4"	62712SSJ 	100	1200
10-32 x 7/8"	62714SSJ 	100	1200
10-32 x 1"	62716SSJ 	100	1200
10-32 x 1 1/2"	62724SSJ 	100	600
10-32 x 2"	62732SSJ 	100	600
10-32 x 2 1/2"	62740SSJ 	100	600
1/4-20 x 3/8"	62906SSJ 	100	1200
1/4-20 x 1/2"	62907SSJ 	100	1200
1/4-20 x 3/4"	62912SSJ 	100	1200
1/4-20 x 1"	62916SSJ 	100	600
1/4-20 x 1 1/4"	62920SSJ 	100	600
1/4-20 x 1 1/2"	62924SSJ 	100	600
1/4-20 x 2"	62932SSJ 	100	600
3/8-16 x 3/4"	63112SSJ 	100	600
3/8-16 x 1"	63116SSJ 	100	600
3/8-16 x 1 1/2"	63124SSJ 	100	600
3/8-16 x 2"	63132SSJ 	100	600

STAINLESS STEEL

FLAT HEAD MACHINE SCREWS - PHILLIPS: TYPE 18-8





		 Gravity Feed Jar		
Size	Part #	Jar Qty	Master Carton	
6-32 x 1/4"	50105SSJ 	100	1200	
6-32 x 1/2"	50109SSJ 	100	1200	
6-32 x 3/4"	50113SSJ 	100	1200	
6-32 x 1"	50117SSJ 	100	1200	
6-32 x 1 1/4"	50121SSJ 	100	1200	
6-32 x 1 1/2"	50125SSJ 	100	1200	
6-32 x 2"	50133SSJ 	100	600	
6-32 x 2 1/2"	50141SSJ 	100	600	
6-32 x 3"	50149SSJ 	100	600	
10-24 x 1/2"	50509SSJ 	100	1200	
10-24 x 3/4"	50513SSJ 	100	1200	
10-24 x 1"	50517SSJ 	100	1200	
10-32 x 1/2"	50709SSJ 	100	1200	
10-32 x 5/8"	50711SSJ 	100	1200	
10-32 x 3/4"	50713SSJ 	100	1200	
10-32 x 1"	50717SSJ 	100	1200	
10-32 x 1 1/4"	50721SSJ 	100	600	
10-32 x 1 1/2"	50725SSJ 	100	600	
10-32 x 2"	50733SSJ 	100	600	
10-32 x 3"	50749SSJ 	100	600	
1/4-20 x 1/2"	50909SSJ 	100	1200	
1/4-20 x 3/4"	50913SSJ 	100	1200	
1/4-20 x 1"	50917SSJ 	100	600	
1/4-20 x 1 1/2"	50925SSJ 	100	600	
1/4-20 x 2"	50933SSJ 	100	600	
1/4-20 x 3"	50949SSJ 	100	600	
5/16-18 x 1"	51017SSJ 	100	600	



- Countersunk (cone shaped under the head) with a flat top.

 Harsh Environment Product

FLAT HEAD MACHINE SCREWS • SLOTTED • TYPE 18-8

		 Gravity Feed Jar		
Size	Bit Size	Part #	Jar Qty	Master Carton
6-32 x 3/4"	#1	60112SSJ 	100	1200
6-32 x 1"	#1	60116SSJ 	100	1200
6-32 x 1 1/2"	#1	60124SSJ 	100	1200
6-32 x 2"	#1	60132SSJ 	100	600



 Harsh Environment Product

OVAL HEAD MACHINE SCREWS - SLOT: TYPE 18-8



- Countersunk (cone shaped under the head) with a rounded top.

	Gravity Feed Jar		
Size	Part #	Jar Qty	Master Carton
6-32 x 1/2"	53608J	100	1200
6-32 x 3/4"	53612J	100	1200
6-32 x 1"	53616J	100	1200

Harsh Environment Product

STOVE BOLTS WITH NUTS - PHILLIPS: TYPE 18-8



- Also referred to as machine screws.
- Machine thread and round head.
- Purchase flat or fender washers concurrently. See pages: 12, 14.

		Gravity Feed Jar		
Size	Hex Nut	Part #	Jar Qty	Master Carton
1/4-20 x 1"	1/4"-20	25516SSJ	100	600
1/4-20 x 1 1/4"	1/4"-20	25520SSJ	100	600
1/4-20 x 1 1/2"	1/4"-20	25524SSJ	100	600

Harsh Environment Product

STAINLESS STEEL

PAN, FLAT & OVAL SPANNER HEAD MACHINE SCREWS: TYPE 18-8

- Tamperproof screws are available by special order only, are subject to minimum order requirements and are non-returnable. Please allow an extra 5–7 days shipping.

Gravity Feed Jar					
Size	Insert Driver	Pan Head Part #	Flat Head Part #	Oval Head Part #	Jar Qty
6-32 x 3/8	#6 Spanner	22506TPJ ★ ♡	20506TPJ ★ ♡	25606TPJ ★ ♡	100
6-32 x 1/2	#6 Spanner	22508TPJ ★ ♡	20508TPJ ★ ♡	25608TPJ ★ ♡	100
6-32 x 3/4	#6 Spanner	22512TPJ ★ ♡	20512TPJ ★ ♡	25612TPJ ★ ♡	100
6-32 x 1	#6 Spanner	22516TPJ ★ ♡	20516TPJ ★ ♡	25616TPJ ★ ♡	100
6-32 x 1 1/4	#6 Spanner	22520TPJ ★ ♡	20520TPJ ★ ♡	25620TPJ ★ ♡	100
6-32 x 1 1/2	#6 Spanner	22524TPJ ★ ♡	20524TPJ ★ ♡	25624TPJ ★ ♡	100
6-32 x 2	#6 Spanner	22532TPJ ★ ♡	20532TPJ ★ ♡	—	100
8-32 x 3/8	#8 Spanner	22606TPJ ★ ♡	20606TPJ ★ ♡	—	100
8-32 x 1/2	#8 Spanner	22608TPJ ★ ♡	20608TPJ ★ ♡	25808TPJ ★ ♡	100
8-32 x 3/4	#8 Spanner	22612TPJ ★ ♡	20612TPJ ★ ♡	25812TPJ ★ ♡	100
8-32 x 1	#8 Spanner	22616TPJ ★ ♡	20616TPJ ★ ♡	25816TPJ ★ ♡	100
8-32 x 1 1/4	#8 Spanner	22620TPJ ★ ♡	20620TPJ ★ ♡	25820TPJ ★ ♡	100
8-32 x 1 1/2	#8 Spanner	22624TPJ ★ ♡	20624TPJ ★ ♡	25824TPJ ★ ♡	100
8-32 x 2	#8 Spanner	22632TPJ ★ ♡	20632TPJ ★ ♡	—	100
10-24 x 1/2	#10 Spanner	22708TPJ ★ ♡	20708TPJ ★ ♡	26008TPJ ★ ♡	100
10-24 x 5/8	#10 Spanner	22710TPJ ★ ♡	20710TPJ ★ ♡	26010TPJ ★ ♡	100
10-24 x 3/4	#10 Spanner	22712TPJ ★ ♡	20712TPJ ★ ♡	26012TPJ ★ ♡	100
10-24 x 1	#10 Spanner	22716TPJ ★ ♡	20716TPJ ★ ♡	26016TPJ ★ ♡	100
10-24 x 1 1/4	#10 Spanner	22720TPJ ★ ♡	20720TPJ ★ ♡	26020TPJ ★ ♡	100
10-24 x 1 1/2	#10 Spanner	22724TPJ ★ ♡	20724TPJ ★ ♡	26024TPJ ★ ♡	100
10-24 x 2	#10 Spanner	22732TPJ ★ ♡	20732TPJ ★ ♡	—	100
10-32 x 1/2	#10 Spanner	22808TPJ ★ ♡	20808TPJ ★ ♡	26208TPJ ★ ♡	100
10-32 x 3/4	#10 Spanner	22812TPJ ★ ♡	20812TPJ ★ ♡	26212TPJ ★ ♡	100
10-32 x 1	#10 Spanner	22816TPJ ★ ♡	20816TPJ ★ ♡	26216TPJ ★ ♡	100

★ Made in USA

♡ Harsh Environment Product



Pan Flat Oval

STAINLESS STEEL

FLAT & BUTTON HEAD SOCKET PIN MACHINE SCREWS: TYPE 18-8



Larger sizes available upon request.

• Tamperproof screws are available by special order only, are subject to minimum order requirements and are non-returnable. Please allow an extra 5–7 days shipping.

Harsh Environment Product

* These parts are packaged in a cardboard box.

Flat Head		Gravity Feed Jar	
Size	Bit	Part #	Jar Qty
6-32 x 3/8	1/8	20506SPJ	100
6-32 x 1/2	1/8	20508SPJ	100
6-32 x 3/4	1/8	20512SPJ	100
6-32 x 1	1/8	20516SPJ	100
8-32 x 3/8	1/8	20606SPJ	100
8-32 x 1/2	1/8	20608SPJ	100
8-32 x 3/4	1/8	20612SPJ	100
8-32 x 1	1/8	20616SPJ	100
10-24 x 3/8	5/32	20706SPJ	100
10-24 x 1/2	5/32	20708SPJ	100
10-24 x 3/4	5/32	20712SPJ	100
10-24 x 1	5/32	20716SPJ	100
10-24 x 1 1/2	5/32	20724SPJ	100
10-32 x 1/2	5/32	20808SPJ	100
10-32 x 3/4	5/32	20812SPJ	100
10-32 x 1	5/32	20816SPJ	100
10-32 x 1 1/2	5/32	20824SPJ	100
1/4-20 x 1/2	5/32	21008SPJ	100
1/4-20 x 3/4	5/32	21012SPJ	100
1/4-20 x 1	5/32	21016SPJ	100
1/4-20 x 1 1/4	5/32	21020SPJ	100
1/4-20 x 1 1/2	5/32	21024SPJ	100
1/4-20 x 2	5/32	21032SPJ	100

Button Head		Gravity Feed Jar	
Size	Bit	Part #	Jar Qty
6-32 x 1/4	1/8	22504SPJ	100
6-32 x 3/8	1/8	22506SPJ	100
6-32 x 1/2	1/8	22508SPJ	100
6-32 x 3/4	1/8	22512SPJ	100
6-32 x 1	1/8	22516SPJ	100
8-32 x 3/8	1/8	22606SPJ	100
8-32 x 1/2	1/8	22608SPJ	100
8-32 x 3/4	1/8	22612SPJ	100
8-32 x 1	1/8	22616SPJ	100
8-32 x 1 1/2	1/8	22624SPJ	100
10-24 x 1/4	5/32	22704SPJ	100
10-24 x 3/8	5/32	22706SPJ	100
10-24 x 1/2	5/32	22708SPJ	100
10-24 x 3/4	5/32	22712SPJ	100
10-24 x 1	5/32	22716SPJ	100
10-24 x 1 1/2	5/32	22724SPJ	100
10-32 x 1/4	5/32	22804SPJ	100
10-32 x 3/8	5/32	22806SPJ	100
10-32 x 1/2	5/32	22808SPJ	100
10-32 x 3/4	5/32	22812SPJ	100
10-32 x 1	5/32	22816SPJ	100
10-32 x 1 1/4	5/32	22820SPJ	100
10-32 x 1 1/2	5/32	22824SPJ	100
10-32 x 2	5/32	22832SPJ	100

FLAT & BUTTON HEAD STAR PIN MACHINE SCREWS

































Harsh Environment Product

Flat Head		Gravity Feed Jar	
Size	Bit	Part #	Jar Qty
6-32 x 3/8	T-10H	20506XPJ	100
6-32 x 1/2	T-10H	20508XPJ	100
6-32 x 3/4	T-10H	20512XPJ	100
6-32 x 1	T-10H	20516XPJ	100
8-32 x 3/8	T-15H	20606XPJ	100
8-32 x 1/2	T-15H	20608XPJ	100
8-32 x 3/4	T-15H	20612XPJ	100
8-32 x 1	T-15H	20616XPJ	100
10-24 x 1/2	T-20H	20708XPJ	100
10-24 x 3/4	T-20H	20712XPJ	100

Button Head		Gravity Feed Jar	
Size	Bit	Part #	Jar Qty
6-32 x 1/4	T-10H	22504XPJ	100
6-32 x 3/8	T-10H	22506XPJ	100
6-32 x 1/2	T-10H	22508XPJ	100
6-32 x 3/4	T-10H	22512XPJ	100
6-32 x 1	T-10H	22516XPJ	100
8-32 x 1/4	T-15H	22604XPJ	100
8-32 x 3/8	T-15H	22606XPJ	100
8-32 x 1/2	T-15H	22608XPJ	100
8-32 x 3/4	T-15H	22612XPJ	100
8-32 x 1	T-15H	22616XPJ	100

PAN HEAD SHEET METAL SCREWS (TAPPING) - PHILLIPS: TYPE 18-8

- Slightly rounded with short vertical sides.



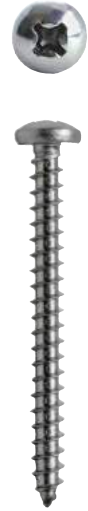



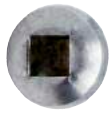

























	 Gravity Feed Jar		
Size	Part #	Jar Qty	Master Carton
#6 x 3/8"	80606SSJ 	100	1200
#6 x 1/2"	80608SSJ 	100	1200
#6 x 3/4"	80612SSJ 	100	1200
#6 x 1"	80616SSJ 	100	1200
#6 x 1 1/2"	80624SSJ 	100	1200
#8 x 3/8"	80806SSJ 	100	1200
#8 x 1/2"	80808SSJ 	100	1200
#8 x 3/4"	80812SSJ 	100	1200
#8 x 1"	80816SSJ 	100	1200
#8 x 1 1/4"	80820SSJ 	100	1200
#8 x 1 1/2"	80824SSJ 	100	1200
#8 x 2"	80832SSJ 	100	600
#10 x 1/2"	81008SSJ 	100	1200
#10 x 5/8"	81010SSJ 	100	1200
#10 x 3/4"	81012SSJ 	100	1200
#10 x 1"	81016SSJ 	100	1200
#10 x 1 1/4"	81020SSJ 	100	1200
#10 x 1 1/2"	81024SSJ 	100	600
#10 x 2"	81032SSJ 	100	600
#10 x 3"	81048SSJ 	100	600
#12 x 1/2"	81208SSJ 	100	1200
#12 x 3/4"	81212SSJ 	100	1200
#12 x 1"	81216SSJ 	100	1200
#12 x 1 1/4"	81220SSJ 	100	600
#12 x 1 1/2"	81224SSJ 	100	600
#12 x 2"	81232SSJ 	100	600
#12 x 3"	81248SSJ 	100	600
#14 x 3/4"	81412SSJ 	100	1200
#14 x 1 1/2"	81424SSJ 	100	600

 Harsh Environment Product

PAN HEAD SHEET METAL SCREWS (TAPPING) - SQUARE DRIVE: TYPE 18-8



- Designed to reduce the risk of cam-out (stripping).
- Allows single-handed installation.

		 Gravity Feed Jar		
Size	Bit	Part #	Jar Qty	Master Carton
6 x 1/2	#1	70608J 	100	1200
6 x 3/4	#1	70612J 	100	1200
6 x 1	#1	70616J 	100	1200
6 x 1 1/4	#1	70620J 	100	1200
8 x 1/2	#2	70808J 	100	1200
8 x 5/8	#2	70810J 	100	1200
8 x 3/4	#2	70812J 	100	1200
8 x 1	#2	70816J 	100	1200
8 x 1 1/4	#2	70820J 	100	1200
8 x 1 1/2	#2	70824J 	100	600
8 x 2	#2	70832J 	100	600
10 x 1/2	#2	71008J 	100	1200
10 x 5/8	#2	71010J 	100	1200
10 x 3/4	#2	71012J 	100	1200
10 x 1	#2	71016J 	100	1200
10 x 1 1/4	#2	71020J 	100	1200
10 x 1 1/2	#2	71024J 	50	600
10 x 2	#2	71032J 	50	600
10 x 2 1/2	#2	71040J 	100	600
12 x 3/4	#3	71212J 	100	1200
12 x 1	#3	71216J 	100	1200
12 x 1 1/4	#3	71220J 	100	600
12 x 1 1/2	#3	71224J 	100	600
12 x 2	#3	71232J 	100	600
12 x 2 1/2	#3	71240J 	100	600
14 x 3/4	#3	71412J 	100	1200
14 x 1	#3	71416J 	100	600
14 x 1 1/4	#3	71420J 	100	600
14 x 1 1/2	#3	71424J 	100	600
14 x 2	#3	71432J 	100	600
14 x 2 1/2	#3	71440J 	100	600
14 x 3	#3	71448J 	100	600

 Harsh Environment Product

STAINLESS STEEL

FLAT & OVAL HEAD SHEET METAL SCREWS • SQUARE DRIVE • TYPE 18-8

Flat Head		Gravity Feed Jar			Oval Head		Gravity Feed Jar		
Size	Bit	Part #	Jar Qty	Master Carton	Size	Bit	Part #	Jar Qty	Master Carton
6 x ½	#1	72608J	100	1200	6 x ½	#1	75608J	100	1200
6 x ¾	#1	72612J	100	1200	6 x ¾	#1	75612J	100	1200
6 x 1	#1	72616J	100	1200	6 x 1	#1	75616J	100	1200
6 x 1¼	#1	72620J	100	1200	8 x ¾	#2	75812J	100	1200
8 x ½	#2	72808J	100	1200	8 x 1	#2	75816J	100	1200
8 x ⅝	#2	72810J	100	1200	8 x 1¼	#2	75820J	100	1200
8 x ¾	#2	72812J	100	1200	8 x 2	#2	75832J	100	600
8 x 1	#2	72816J	100	1200	10 x ¾	#2	76012J	100	1200
8 x 1¼	#2	72820J	100	1200	10 x 1	#2	76016J	100	1200
8 x 1½	#2	72824J	100	1200	10 x 1¼	#2	76020J	100	1200
8 x 1¾	#2	72828J	100	600	10 x 1½	#2	76024J	100	600
8 x 2	#2	72832J	100	600	10 x 1¾	#2	76028J	100	600
8 x 2½	#2	72840J	100	600	10 x 2	#2	76032J	100	600
8 x 3	#2	72848J	100	600	10 x 2½	#2	76040J	100	600
10 x ¾	#2	73012J	100	1200	10 x 3	#2	76048J	100	600
10 x 1	#2	73016J	100	1200					
10 x 1¼	#2	73020J	100	1200					
10 x 1½	#2	73024J	100	600					
10 x 1¾	#2	73028J	100	600					
10 x 2	#2	73032J	100	600					
10 x 2½	#2	73040J	100	600					
10 x 3	#2	73048J	100	600					
12 x 1	#3	73216J	100	1200					
12 x 1¼	#3	73220J	100	600					
12 x 1½	#3	73224J	100	600					
12 x 1¾	#3	73228J	100	600					
12 x 2	#3	73232J	100	600					
12 x 2½	#3	73240J	100	600					
12 x 3	#3	73248J	100	600					
14 x 1	#3	73416J	100	600					
14 x 1¼	#3	73420J	100	600					
14 x 1½	#3	73424J	100	600					
14 x 2	#3	73432J	100	600					
14 x 2½	#3	73440J	100	600					
14 x 3	#3	73448J	100	600					



 Harsh Environment Product

HEX WASHER HEAD SHEET METAL SCREWS (TAPPING) - SLOT: TYPE 18-8



- Can be installed with either a wrench or a flat bladed screw driver.
- Built-in washer.

	Gravity Feed Jar		
Size	Part #	Jar Qty	Master Carton
#8 x 1/2"	76808SSJ	100	1200
#8 x 3/4"	76812SSJ	100	1200
#8 x 1 1/4"	76820SSJ	100	1200
#10 x 3/4"	77012SSJ	100	1200
#10 x 1"	77016SSJ	100	1200
#10 x 1 1/4"	77020SSJ	100	600
#10 x 1 1/2"	77024SSJ	100	600
#10 x 2"	77032SSJ	100	600
#12 x 1/2"	77208SSJ	100	1200
#12 x 3/4"	77212SSJ	100	1200
#14 x 1"	77416SSJ	100	600
#14 x 1 1/4"	77420SSJ	100	600

Harsh Environment Product

TRIM HEAD WOOD SCREWS • SQUARE DRIVE



		Gravity Feed Jar		
Size	Bit Size	Part #	Jar Qty	Master Carton
7 x 1 5/8"	#1	72726J	100	600
7 x 2 1/4"	#1	72736J	100	600
7 x 3"	#1	72748J	100	600

Harsh Environment Product

STAINLESS STEEL

PAN, FLAT & OVAL HEAD SPANNER HEAD SHEET METAL SCREWS: TYPE 18-8

- Tamperproof screws are available by special order only, are subject to minimum order requirements and are non-returnable. Please allow an extra 5–7 days shipping.

		Gravity Feed Jar			
Size	Insert Driver	Pan Head Spanner	Flat Head Spanner	Oval Head Spanner	Jar Qty
6 x 3/8	#6 Spanner	10606TPJ ★	12606TPJ ★	—	100
6 x 1/2	#6 Spanner	10608TPJ ★	12608TPJ ★	14608TPJ ★	100
6 x 5/8	#6 Spanner	10610TPJ ★	12610TPJ ★	—	100
6 x 3/4	#6 Spanner	10612TPJ ★	12612TPJ ★	14612TPJ ★	100
6 x 1	#6 Spanner	10616TPJ ★	12616TPJ ★	14616TPJ ★	100
6 x 1 1/4	#6 Spanner	10620TPJ ★	12620TPJ ★	14620TPJ ★	100
6 x 1 1/2	#6 Spanner	10624TPJ ★	12624TPJ ★	14624TPJ ★	100
6 x 2	#6 Spanner	10632TPJ ★	12632TPJ ★	—	100
8 x 3/8	#8 Spanner	10806TPJ ★	12806TPJ ★	—	100
8 x 1/2	#8 Spanner	10808TPJ ★	12808TPJ ★	14808TPJ ★	100
8 x 3/4	#8 Spanner	10812TPJ ★	12812TPJ ★	14812TPJ ★	100
8 x 1	#8 Spanner	10816TPJ ★	12816TPJ ★	14816TPJ ★	100
8 x 1 1/4	#8 Spanner	10820TPJ ★	12820TPJ ★	14820TPJ ★	100
8 x 1 1/2	#8 Spanner	10824TPJ ★	12824TPJ ★	14824TPJ ★	100
8 x 2	#8 Spanner	10832TPJ ★	12832TPJ ★	—	100
10 x 1/2	#10 Spanner	11008TPJ ★	13008TPJ ★	15008TPJ ★	100
10 x 5/8	#10 Spanner	11010TPJ ★	13010TPJ ★	15010TPJ ★	100
10 x 3/4	#10 Spanner	11012TPJ ★	13012TPJ ★	15012TPJ ★	100
10 x 1	#10 Spanner	11016TPJ ★	13016TPJ ★	15016TPJ ★	100
10 x 1 1/4	#10 Spanner	11020TPJ ★	13020TPJ ★	15020TPJ ★	100
10 x 1 1/2	#10 Spanner	11024TPJ ★	13024TPJ ★	15024TPJ ★	100
10 x 2	#10 Spanner	11032TPJ ★	13032TPJ ★	—	100
12 x 1/2	#12 Spanner	11208TPJ ★	13208TPJ ★	—	100
12 x 3/4	#12 Spanner	11212TPJ ★	13212TPJ ★	—	100
12 x 1	#12 Spanner	11216TPJ ★	13216TPJ ★	—	100
12 x 1 1/4	#12 Spanner	11220TPJ ★	13220TPJ ★	—	100
12 x 1 1/2	#12 Spanner	11224TPJ ★	13224TPJ ★	—	100
12 x 2	#12 Spanner	11232TPJ ★	13232TPJ ★	—	100
14 x 1/2	#14 Spanner	11408TPJ ★	13408TPJ ★	—	100
14 x 3/4	#14 Spanner	11412TPJ ★	13412TPJ ★	—	100
14 x 1	#14 Spanner	11416TPJ ★	13416TPJ ★	—	100
14 x 1 1/4	#14 Spanner	11420TPJ ★	13420TPJ ★	—	100



Pan Flat Oval





Get a 16-in-1 Tamperproof Screwdriver!

Part #37011.
See page 123 for details.

STAINLESS STEEL

★ Made in USA

🛡️ Harsh Environment Product

BUTTON HEAD SOCKET PIN SHEET METAL SCREWS: TYPE 18-8



- Tamperproof screws are available by special order only, are subject to minimum order requirements and are non-returnable. Please allow an extra 5–7 days shipping.

Gravity Feed Jar				
Size	Driver	Part #	Jar Qty	Master Carton
8 x 3/4	1/8	10812SPJ ★ ♡	100	1200
8 x 1	1/8	10816SPJ ★ ♡	100	1200
10 x 1/2	5/32	11008SPJ ★ ♡	100	1200
10 x 3/4	5/32	11012SPJ ★ ♡	100	1200
10 x 1	5/32	11016SPJ ★ ♡	100	1200

★ Made in USA

♡ Harsh Environment Product

BUTTON HEAD STAR PIN (TORX) SHEET METAL SCREWS: TYPE 18-8



Gravity Feed Jar				
Size	Driver	Part #	Jar Qty	Master Carton
8 x 1/2	T-15H	10808XPJ ★ ♡	100	1200
8 x 3/4	T-15H	10812XPJ ★ ♡	100	1200
8 x 1	T-15H	10816XPJ ★ ♡	100	1200
8 x 1 1/4	T-15H	10820XPJ ★ ♡	100	1200
10 x 1/2	T-25H	11008XPJ ★ ♡	100	1200
10 x 3/4	T-25H	11012XPJ ★ ♡	100	1200
10 x 1	T-25H	11016XPJ ★ ♡	100	1200
10 x 1 1/4	T-25H	11020XPJ ★ ♡	100	1200
10 x 1 1/2	T-25H	11024XPJ ★ ♡	100	1200

★ Made in USA

♡ Harsh Environment Product

FLAT HEAD STAR PIN (TORX) SHEET METAL SCREWS: TYPE 18-8



Gravity Feed Jar				
Size	Driver	Part #	Jar Qty	Master Carton
8 x 3/4	T-15H	12812XPJ ★ ♡	100	1200
8 x 1	T-15H	12816XPJ ★ ♡	100	1200
8 x 1 1/4	T-15H	12820XPJ ★ ♡	100	1200
10 x 3/4	T-20H	13012XPJ ★ ♡	100	1200
10 x 1	T-20H	13016XPJ ★ ♡	100	1200
10 x 1 1/4	T-20H	13020XPJ ★ ♡	100	1200

★ Made in USA

♡ Harsh Environment Product

STAINLESS STEEL

HEX WASHER HEAD TEK SCREWS (SELF-DRILLING): TYPE 410

- Drill bit point.
- Hexagonal head for use with a wrench.



Gravity Feed Jar				
Size	Drill Point	Part #	Jar Qty	Master Carton
#6 x 3/8"	#2	78606SSJ	100	1200
#6 x 1"	#2	78616SSJ	100	1200
#8 x 1/2"	#2	78808SSJ	100	1200
#8 x 3/4"	#2	78812SSJ	100	1200
#8 x 1"	#2	78816SSJ	100	1200
#8 x 1 1/2"	#2	78824SSJ	100	1200
#8 x 2"	#2	78832SSJ	100	600
#10 x 1/2"	#2	79008SSJ	100	1200
#10 x 3/4"	#2	79012SSJ	100	1200
#10 x 1"	#3	79016SSJ	100	1200
#10 x 1 1/2"	#3	79024SSJ	100	600
#10 x 2"	#3	79032SSJ	100	600
#12 x 3/4"	#3	79212SSJ	100	1200
#12 x 1"	#3	79216SSJ	100	1200
#12 x 1 1/2"	#3	79224SSJ	100	600
#14 x 3/4"	#3	79412SSJ	100	600
#14 x 1"	#3	79416SSJ	100	600
#14 x 3"	#3	79448SSJ	100	600

Harsh Environment Product

THREADED ROD: TYPE 18-8



- Long steel rod with machine-threads along the complete length of the rod.
- When shipping an order including 10' lengths and over, contact customer service for minimum freight pre-pay.
- Rod is sold per piece, not per foot.

Type 18-8		
Size	Part #	Tube Qty
1/4"-20 X 3'	71931 ♡	50
5/16"-18 X 3'	71932 ♡	35
3/8"-16 X 3'	71933 ♡	25
1/2"-13 X 3'	71934 ♡	36
1/4"-20 X 6'	71961 ♡	50
5/16"-18 X 6'	71962 ♡	35
3/8"-16 X 6'	71963 ♡	25
1/2"-13 X 6'	71964 ♡	12
1/4"-20 X 12'	71921 ♡	50
5/16"-18 X 12'	71922 ♡	35
3/8"-16 X 12'	71923 ♡	25
1/2"-13 X 12'	71924 ♡	12

Dimension All Thread Rod (ATR)

- Dimensions taken from ANSI B1.1-1982 Unified Inch Screw Threads.
- All threads are UNCR series.
- Tabulated loads are based on an allowable tensile stress of 12000 psi (82.7 MPa) reduced by 25% resulting in 9000 psi (62 MPa). From ANSI/MSS SP-58, Table 3.

Nominal Size & Thread	Root Area		Design Load (SF=5)	
	in. ²	cm ²	lbs	kN
1/4 - 20	0.027	0.174	240	1.07
5/16 - 18	0.045	0.290	400	1.78
3/8 - 16	0.068	0.438	610	2.71

HEX ROD COUPLING: TYPE 18-8

- Elongated hex nuts used to join threaded rod.



Size	Gravity Feed Jar		
	Part #	Jar Qty	Master Carton
1/4"-20	59604SSJ ♡	100	600
5/16"-18	59605SSJ ♡	100	600
3/8"-16	59606SSJ ♡	100	600
1/2"-13	59608SSJ ♡	50	300
5/8"-11	59610SS* ♡	50	50

JACK CHAIN: TYPE 304

 Cardboard Box			
Work Load Limit (lbs)	Gauge	Part #	Box Qty
43	#10	72010SS ★ ♡	100'
29	#12	72012SS ★ ♡	100'



★ Made in USA

♡ Harsh Environment Product

S-HOOKS: TYPE 304

 Gravity Feed Jar			
Size	Part #	Jar Qty	Master Carton
1½"	70024SSJ ★ ♡	100	600



★ Made in USA

♡ Harsh Environment Product

BRIDLE RINGS: TYPE 304



		Cardboard Box	
Size	Diameter	Part #	Box Qty
1/4"-20	2"	648RSS ★ ♡	100

- ★ Made in USA
- ♡ Harsh Environment Product

MEGAPRO 15-IN-1 SCREWDRIVER



		Cardboard Box	
Description	Part #	Box Qty	
Stainless Steel Shaft with Nickel Plated Bits, Phillips (#0,#1,#2), Square (#0,#1,#2), Star (T10,T15,T20&T25), Slotted (#4), & Shaft is 1/4" Hex, Yellow/Blue	37285 ★ ♡	100	

- ★ Made in USA
- ♡ Harsh Environment Product

STAINLESS STEEL

Minerallac

Strut Fittings

Wide and Varied Selection

Minerallac Strut Fittings and Accessories offers expansive lines of fittings, clamps, and hardware for strut systems.

Standard and specialty finishes include:

- 304 Stainless Steel
- 316 Stainless Steel
- Aluminum
- Hot-Dipped Galvanized
- Zinc Electroplate (EG)
- Yellow Chromate
- Powder Coated Green
- Epoxy
- Copper Chromate

260-261 Channel Nuts

262 Swivels

263-268 Strut Clamps

269-272 Flat Fittings

273-280 Angle Fittings

281-287 Beam Clamps

288-293 Brackets

294 End Caps

295-297 Electrical

298-300 Post Bases

300-302 Rollers

303-306 U-Fittings

306-309 Wing Fittings

310-312 Z-Fittings

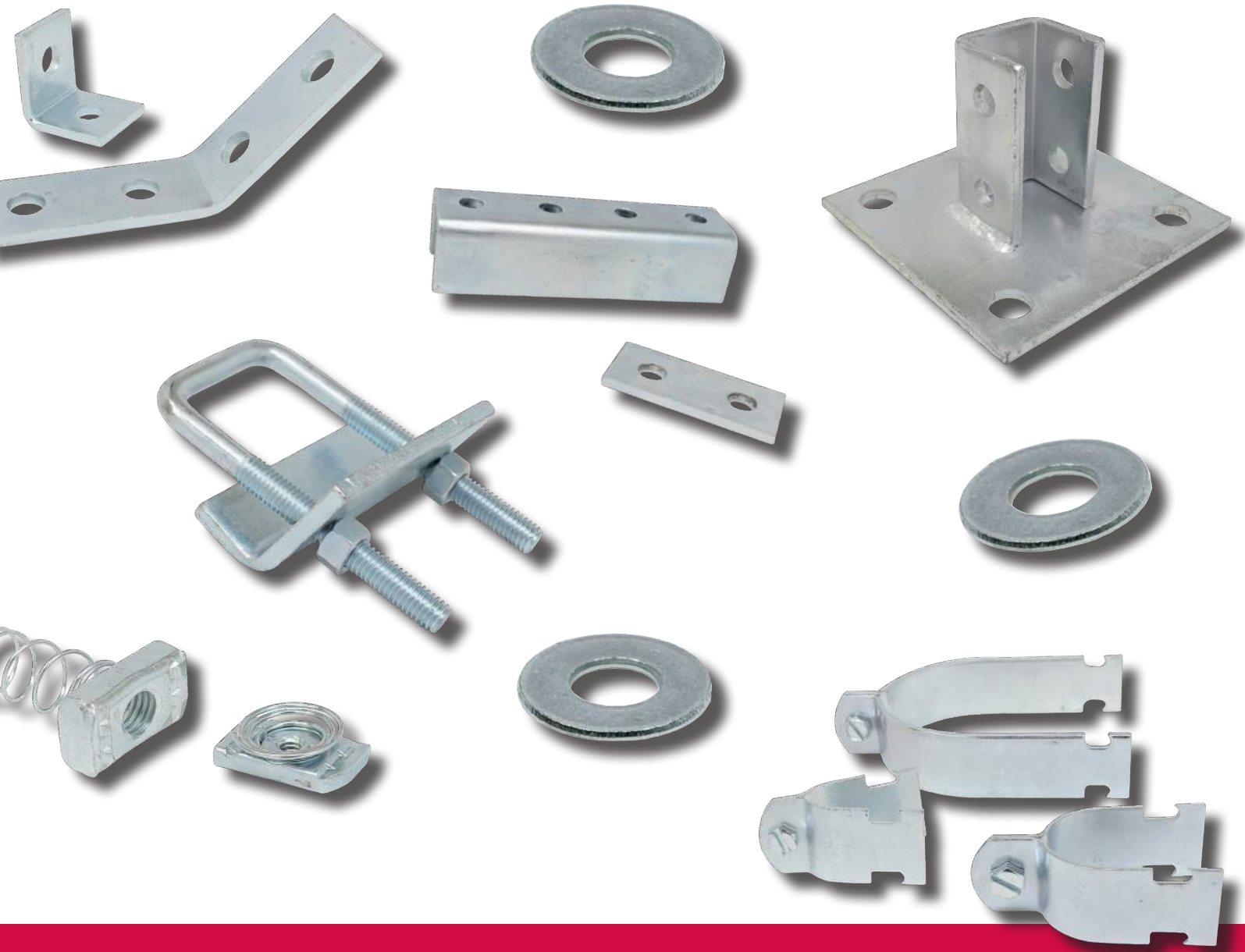

SPRING NUT

- Standard finish is Zinc Electroplate.
- For 1-3/8" & 1-5/8" channel.
- * Import item. Call for domestic availability.

Part #	Thread Size (TH)	T		Box Qty
		in	mm	
SN010EG*	10-24"	0.25	6.3	100
SN025EG*	1/4"-20"	0.25	6.3	100
SN031EG*	5/16"-18"	0.25	6.3	100
SN037EG*	3/8"-16"	0.25	6.3	100
SN050EG*	1/2"-13"	0.37	9.4	100
SN062EG*	5/8"-11"	0.5	12.7	50
SN075EG*	3/4"-10"	0.5	12.7	50
SN087EG*	7/8"-9"	0.5	12.7	50

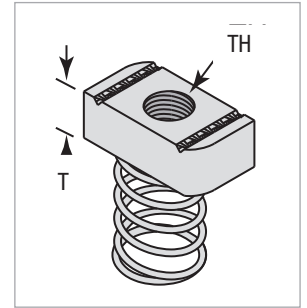

SHORT SPRING

- Standard finish is Zinc Electroplate.
- For 13/16" & 1" channel.
- * Import item. Call for domestic availability.

Part #	Thread Size (TH)	T		Box Qty
		in	mm	
Zinc Electroplate				
SNS010EG*	10-24"	0.25	6.3	100
SNS025EG*	1/4"-20"	0.25	6.3	100
SNS031EG*	5/16"-18"	0.25	6.3	100
SNST031EG*	5/16"-18"	0.37	9.4	100
SNS037EG*	3/8"-16"	0.25	6.3	100
SNST037EG*	3/8"-16"	0.37	9.4	100
SNST050EG*	1/2"-13"	0.37	9.4	100
SNS062EG*	5/8"-11"	0.37	9.4	100

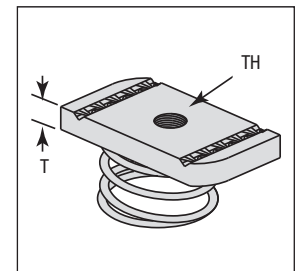

SNT037EG*

NO SPRING CHANNEL NUT

Part #	Thread Size (TH)	T		Box Qty
		in	mm	
Zinc Electroplate				
CNN010EG*	10-24"	0.25	6.3	100
CNN025EG*	1/4"-20"	0.25	6.3	100
CNN031EG*	5/16"-18"	0.37	9.4	100
CNN037EG*	3/8"-16"	0.37	9.4	100
CNN050EG*	1/2"-13"	0.37	9.4	100
CNNT050EG** *	1/2"-13"	0.5	12.7	100
CNN062EG**	5/8"-11"	0.37	9.4	100
CNNT062EG** *	5/8"-11"	0.5	12.7	100
CNN075EG*	3/4"-10"	0.37	9.4	100
CNNT075EG** *	3/4"-10"	0.5	12.7	100
CNNT087EG** *	7/8"-9"	0.5	12.7	100



CNN037EG

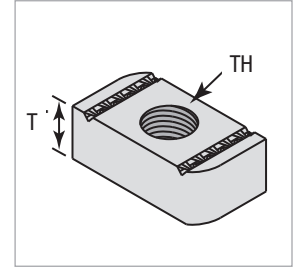

- Standard finish is Zinc Electroplate.
- For all channel sizes except noted sizes.
- * Import item. Call for domestic availability.
- ** Cannot be used with 1 3/16" & 1" channel.
- Photo shown in Stainless Steel Finish.

LONG SPRING NUT

- Standard finish is Zinc Electroplate.
- For 2-7/16" & 3-1/4" channel.
- * Import item. Call for domestic availability.

Part #	Thread Size (TH)	T		Box Qty
		in	mm	
SNL025EG*	1/4"-20"	0.25	6.3	100
SNL037EG*	3/8"-16"	0.37	9.4	50
SNL050EG*	1/2"-13"	0.5	12.7	50

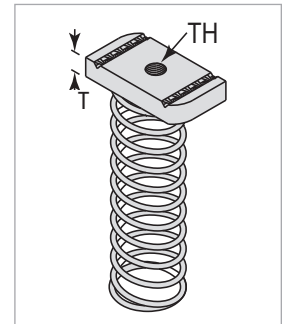

TOP SPRING NUT

- Standard finish is Zinc Electroplate.
- For all channel sizes except noted sizes.
- ** Cannot be used with 1 3/16" & 1" channel.
- * Import item. Call for domestic availability.

Part #	Thread Size (TH)	T		Box Qty
		in	mm	
TN025EG*	1/4"-20"	0.25	6.3	100
TN037EG*	3/8"-16"	0.37	9.4	100
TN050EG*	1/2"-13"	0.37	9.4	100
TNT050EG** *	1/2"-13"	0.5	12.7	100

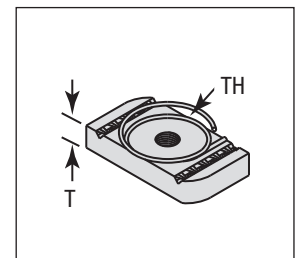

SWIVEL FEMALE

• Standard finish is Zinc Electroplate.

Part #	RS	L		R		Design Load		Box Qty
		in	mm	in	mm	lbs.	kN	
SWF037EG ★	3/8"-16	1 3/4	44.4	1/4	6.3	620	2.76	50
SWF050EG ★	1/2"-13	2	50.8	3/8	9.4	1150	5.12	50

★ Made in USA

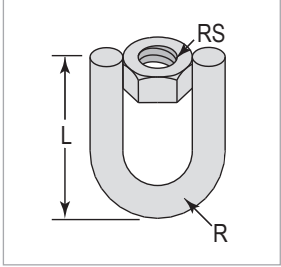

SWIVEL MALE

• Standard finish is Zinc Electroplate.

Part #	Thread Size (TH)	L		R		Design Load		Box Qty
		in	mm	in	mm	lbs.	kN	
SWM037EG ★	3/8"-16	1 3/4	44.4	1/4	6.3	620	2.76	50
SWM050EG ★	1/2"-13	2	50.8	3/8	9.4	1150	5.12	50

★ Made in USA

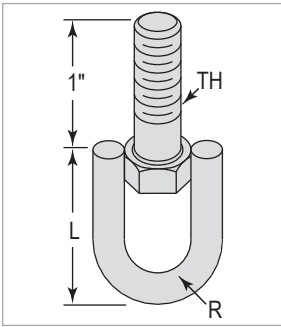

SWIVEL FEMALE - FEMALE

• Standard finish is Zinc Electroplate.

Part #	RS	L		Design Load		Box Qty
		in	mm	lbs.	kN	
SWFF037EG ★	3/8"-16	2 3/4	69.8	620	2.76	50
SWFF050EG ★	1/2"-13	3	76.2	1150	5.12	50

★ Made in USA

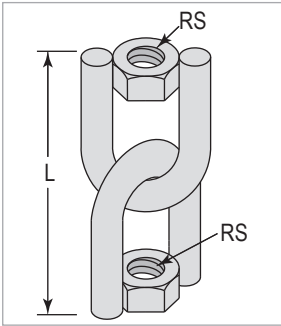

SWIVEL MALE - FEMALE

• Standard finish is Zinc Electroplate.

Part #	Thread Size (TH)	RS	L		Design Load		Box Qty
			in	mm	lbs.	kN	
SWMF037EG ★	3/8"-16	3/8"-16	2 3/4	69.8	620	2.76	50
SWMF050EG ★	1/2"-13"	1/2"-13	3	76.2	1150	5.12	50

★ Made in USA

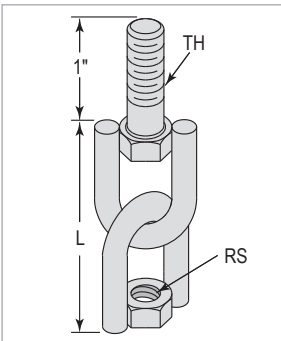

RIGID CONDUIT STRUT CLAMPS

- Standard finish is Zinc Electroplate.

Part #	Rigid Conduit Size		O.D.		Design Load		Box Qty
	in	mm	in	mm	lbs.	kN	
CCR025EG ★	¼	6	0.54	13.7	400	1.78	100
CCR037EG ★	⅜	10	0.675	17.1	400	1.78	100
CCR050EG ★	½	15	0.84	21.3	400	1.78	100
CCR075EG ★	¾	20	1.05	26.7	600	2.67	100
CCR100EG ★	1	25	1.315	33.4	600	2.67	100
CCR125EG ★	1¼	32	1.66	42.2	600	2.67	50
CCR150EG ★	1½	40	1.9	48.3	800	3.56	50
CCR200EG ★	2	50	2.375	60.3	800	3.56	50
CCR250EG ★	2½	65	2.875	73	800	3.56	50
CCR300EG ★	3	80	3.5	88.9	800	3.56	25
CCR350EG ★	3½	90	4	101.6	1000	4.45	25
CCR400EG ★	4	100	4.5	114.3	1000	4.45	25
CCR500EG ★	5	125	5.562	141.3	1000	4.45	25
CCR600EG ★	6	150	6.625	168.3	1000	4.45	25
CCR800EG ★	8	200	8.625	219.1	1000	4.45	25
CCR1000EG ★	10	250	10.75	273.1	1000	4.45	25
CCR1200EG ★	12	300	12.75	323.9	1000	4.45	25

★ Made in USA

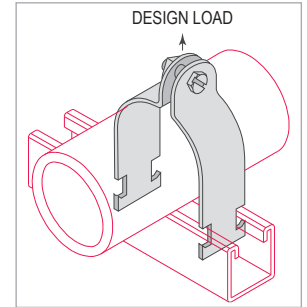

UNIVERSAL CONDUIT STRUT CLAMPS

- Standard finish is Zinc Electroplate.
- *These clamps are designed to fit both pipe (rigid conduit) and thin walled tubing (EMT) in the corresponding sizes.

Part #	Conduit Size		O.D.		Design Load		Box Qty
	in	mm	in	mm	lbs.	kN	
CCU050EG ★	½	15	0.773	19.6	400	1.78	100
CCU075EG ★	¾	20	0.986	25	600	2.67	100
CCU100EG ★	1	25	1.239	31.5	600	2.67	100
CCU125EG ★	1¼	32	1.585	40.3	600	2.67	50
CCU150EG ★	1½	40	1.82	45.7	800	3.56	50
CCU200EG ★	2	50	2.286	58.1	800	3.56	50

★ Made in USA

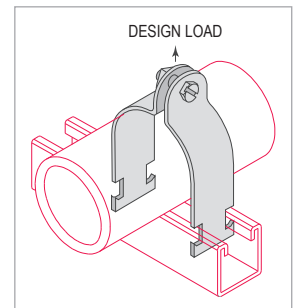

EMT CONDUIT STRUT CLAMPS

Part #	EMT Conduit Size		O.D.		Design Load		Box Qty
	in	mm	in	mm	lbs.	kN	
CCE037EG ★	3/8	10	0.557	14.2	400	1.78	25
CCE050EG ★	1/2	15	0.706	17.9	400	1.78	100
CCE075EG ★	3/4	20	0.922	23.4	400	1.78	100
CCE100EG ★	1	25	1.163	29.5	600	2.67	100
CCE125EG ★	1 1/4	32	1.51	38.4	600	2.67	50
CCE150EG ★	1 1/2	40	1.74	44.2	800	3.56	50
CCE200EG ★	2	50	2.197	55.8	800	3.56	50

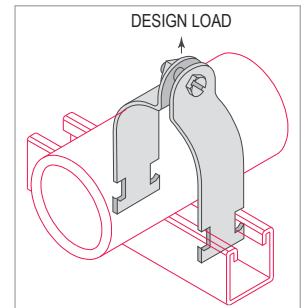

• Standard finish is Zinc Electroplate.

★ Made in USA

ONE PIECE STRUT CLAMP WITH SADDLE

Part #	EMT Conduit Size (in)	RMC Conduit Size (in)	Box Qty
CCOP50 ★	1/2	-	100
CCOP75 ★	3/4	1/2	100
CCOP100 ★	1	3/4	100
CCOP125 ★	1 1/4	1	100
CCOP150 ★	1 1/2	1 1/4	50
CCOP200 ★	2	1	50
CCOP200R ★	-	2	25
CCOP250 ★	2 1/2	2 1/2	25
CCOP300 ★	3	3	25
CCOP350 ★	3 1/2	3 1/2	10
CCOP400 ★	4	4	10



CCOP50

• Made from pre-galvanized steel.

★ Made in USA

COPPER TUBING CONDUIT STRUT CLAMPS

Part #	Tubing Size		O.D.		Design Load		Box Qty
	in	mm	in	mm	lbs.	kN	
CCC025CP ★	1/4	6	0.375	9.5	400	1.78	100
CCC037CP ★	3/8	10	0.5	12.7	400	1.78	25
CCC050CP ★	1/2	15	0.625	15.9	400	1.78	100
CCC075CP ★	3/4	20	0.875	22.2	400	1.78	100
CCC100CP ★	1	25	1.125	28.6	600	2.67	100
CCC125CP ★	1 1/4	32	1.375	34.9	600	2.67	50
CCC150CP ★	1 1/2	40	1.625	41.3	600	2.67	50
CCC200CP ★	2	50	2.125	54	800	3.56	50
CCC250CP ★	2 1/2	65	2.625	66.7	800	3.56	50
CCC300CP ★	3	80	3.125	79.4	800	3.56	50
CCC350CP ★	3 1/2	90	3.625	92.1	1000	4.45	25
CCC400CP ★	4	100	4.125	104.8	1000	4.45	25
CCC500CP ★	5	125	5.125	130.2	1000	4.45	25
CCC600CP ★	6	150	6.125	155.6	1000	4.45	25

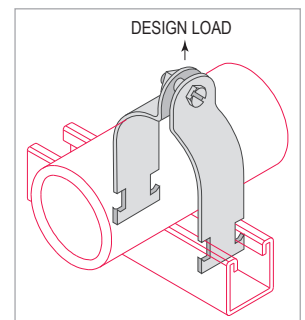

• Standard finish is Copper Zinc Dichromate which has a copper color to identify product for use with copper tubing.

★ Made in USA

O.D. CONDUIT STRUT CLAMPS

• Standard finish is Zinc Electroplate.

Part #	O.D.		Design Load		Box Qty	
	in	mm	lbs.	kN		
CCOD025EG ★	¼	0.25	6.4	400	1.78	100
CCOD037EG ★	⅜	0.375	9.5	400	1.78	100
CCOD050EG ★	½	0.5	12.7	400	1.78	100
CCOD062EG ★	⅝	0.625	15.9	400	1.78	100
CCOD075EG★	¾	0.75	19	400	1.78	100
CCOD087EG★	⅞	0.875	22.3	400	1.78	100
CCOD100EG ★	1	1	25.4	600	2.67	100
CCOD112EG ★	1⅛	1.125	28.6	600	2.67	100
CCOD125EG ★	1¼	1.25	31.8	600	2.67	100
CCOD137EG ★	1⅜	1.375	34.9	600	2.67	50
CCOD150EG ★	1½	1.5	38.1	600	2.67	50
CCOD162EG ★	1⅝	1.625	41.3	600	2.67	50
CCOD175EG ★	1¾	1.75	44.5	800	3.56	50
CCOD187EG ★	1⅞	1.875	47.6	800	3.56	50
CCOD200EG ★	2	2	50.8	800	3.56	50
CCOD212EG ★	2⅛	2.125	54	800	3.56	50
CCOD225EG ★	2¼	2.25	57.2	800	3.56	50
CCOD237EG ★	2⅜	2.375	60.3	800	3.56	50
CCOD250EG ★	2½	2.5	63.5	800	3.56	50
CCOD262EG ★	2⅝	2.625	66.7	800	3.56	50
CCOD275EG ★	2¾	2.75	69.9	800	3.56	50
CCOD287EG ★	2⅞	2.875	73	800	2.56	50
CCOD300EG★	3	3	76.2	800	3.56	50
CCOD312EG ★	3⅛	3.125	79.4	800	3.56	50
CCOD325EG ★	3¼	3.25	82.6	800	3.56	50
CCOD337EG ★	3⅝	3.375	85.7	800	3.56	50
CCOD350EG ★	3½	3.5	88.9	800	3.56	50
CCOD362EG ★	3⅞	3.625	92.1	1000	3.56	25
CCOD375EG ★	3¾	3.75	95.3	1000	4.45	25
CCOD387EG ★	3⅞	3.875	98.4	1000	4.45	25
CCOD400EG ★	4	4	101.6	1000	4.45	25
CCOD412EG ★	4⅛	4.125	104.8	1000	4.45	25
CCOD425EG ★	4¼	4.25	108	1000	4.45	25
CCOD437EG ★	4⅝	4.375	111.1	1000	4.45	25
CCOD450EG ★	4½	4.5	114.3	1000	4.45	25
CCOD462EG ★	4⅞	4.625	117.5	1000	4.45	25
CCOD475EG ★	4¾	4.75	120.7	1000	4.45	25
CCOD487EG ★	4⅞	4.875	123.8	1000	4.45	25

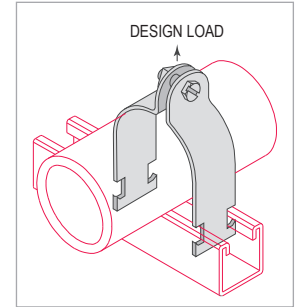

★ Made in USA

O.D. CONDUIT STRUT CLAMPS CONT.

• Standard finish is Zinc Electroplate.

Part #	O.D.			Design Load		Box Qty
	in	in	mm	lbs.	kN	
CCOD500EG ★	5	5	127	1000	4.45	25
CCOD512EG ★	5 $\frac{1}{8}$	5.125	130.2	1000	4.45	25
CCOD525EG ★	5 $\frac{1}{4}$	5.25	133.4	1000	4.45	25
CCOD537EG ★	5 $\frac{3}{8}$	5.375	136.5	1000	4.45	25
CCOD550EG ★	5 $\frac{1}{2}$	5.5	139.7	1000	4.45	25
CCOD562EG ★	5 $\frac{5}{8}$	5.625	142.9	1000	4.45	25
CCOD575EG ★	5 $\frac{3}{4}$	5.75	146.1	1000	4.45	25
CCOD587EG ★	5 $\frac{7}{8}$	5.875	149.2	1000	4.45	25
CCOD600EG ★	6	6	152.4	1000	4.45	25
CCOD612EG ★	6 $\frac{1}{8}$	6.125	155.6	1000	4.45	25
CCOD625EG ★	6 $\frac{1}{4}$	6.25	158.8	1000	4.45	25
CCOD637EG ★	6 $\frac{3}{8}$	6.375	161.9	1000	4.45	25
CCOD650EG ★	6 $\frac{1}{2}$	6.5	165.1	1000	4.45	25
CCOD662EG ★	6 $\frac{5}{8}$	6.625	168.3	1000	4.45	25
CCOD675EG ★	6 $\frac{3}{4}$	6.75	171.5	1000	4.45	25
CCOD687EG ★	6 $\frac{7}{8}$	6.875	174.6	1000	4.45	25
CCOD700EG ★	7	7	177.8	1000	4.45	25
CCOD712EG ★	7 $\frac{1}{8}$	7.125	181	1000	4.45	25
CCOD725EG ★	7 $\frac{1}{4}$	7.25	184.2	1000	4.45	25
CCOD737EG ★	7 $\frac{3}{8}$	7.375	187.3	1000	4.45	25
CCOD750EG ★	7 $\frac{1}{2}$	7.5	190.5	1000	4.45	25
CCOD762EG ★	7 $\frac{5}{8}$	7.625	193.7	1000	4.45	25
CCOD775EG ★	7 $\frac{3}{4}$	7.75	196.9	1000	4.45	25
CCOD787EG ★	7 $\frac{7}{8}$	7.875	200	1000	4.45	25
CCOD812EG ★	8 $\frac{1}{8}$	8.125	206.4	1000	4.45	25
CCOD825EG ★	8 $\frac{1}{4}$	8.25	209.6	1000	4.45	25
CCOD837EG ★	8 $\frac{3}{8}$	8.375	212.7	1000	4.45	25
CCOD850EG ★	8 $\frac{1}{2}$	8.5	215.9	1000	4.45	25
CCOD862EG ★	8 $\frac{5}{8}$	8.625	219.1	1000	4.45	25
CCOD875EG ★	8 $\frac{3}{4}$	8.75	196.9	1000	4.45	25
CCOD887EG ★	8 $\frac{7}{8}$	8.875	200	1000	4.45	25
CCOD900EG ★	9	9	228.6	1000	4.45	25

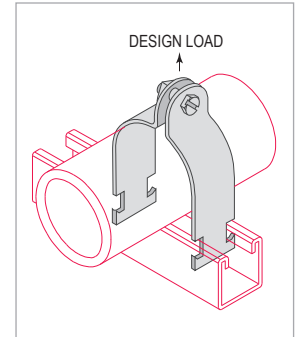

★ Made in USA

TUBING CUSHION STRUT CLAMPS

- Standard finish is Yellow Zinc Dichromate.

Part #	Pipe Size O.D.			Box Qty
	in	in	mm	
CCT025YC ★	¼	0.25	6.4	25
CCT037YC ★	⅜	0.375	9.5	25
CCT050YC ★	½	0.5	12.7	25
CCT062YC ★	⅝	0.625	15.9	25
CCT075YC ★	¾	0.75	19	25
CCT087YC ★	⅞	0.875	22.3	25
CCT100YC ★	1	1	25.4	20
CCT112YC ★	1⅛	1.125	28.6	10
CCT125YC ★	1¼	1.25	31.8	10
CCT137YC ★	1⅜	1.375	34.9	10
CCT150YC ★	1½	1.5	38.1	10
CCT162YC ★	1⅝	1.625	41.3	10
CCT175YC ★	1¾	1.75	44.5	10
CCT187YC ★	1⅞	1.875	47.6	10
CCT200YC ★	2	2	50.8	10
CCT212YC ★	2⅛	2.125	54	10
CCT225YC ★	2¼	2.25	57.2	10
CCT250YC ★	2½	2.5	63.5	10
CCT262YC ★	2⅝	2.625	66.7	10
CCT312YC ★	3⅞	3.125	79.4	10
CCT362YC ★	3⅝	3.625	92.1	10
CCT412YC ★	4⅞	4.125	104.8	10

★ Made in USA

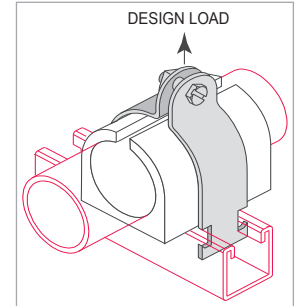

PIPE CUSHION STRUT CLAMPS

- Standard finish is Yellow Zinc Dichromate.

Part #	Pipe Size O.D.		PIPE O.D.		Box Qty
	in	din	in	mm	
CCP037YC ★	3/8	10	0.675	17.1	25
CCP050YC ★	1/2	15	0.84	21.3	25
CCP075YC ★	3/4	20	1.05	26.7	25
CCP100YC ★	1	25	1.315	33.4	25
CCP125YC ★	1 1/4	32	1.66	42.2	10
CCP150YC ★	1 1/2	40	1.9	48.3	10
CCP200YC ★	2	50	2.375	60.3	10
CCP250YC ★	2 1/2	65	2.875	73	10
CCP300YC ★	3	80	3.5	88.9	10
CCP350YC ★	3 1/2	90	4	101.6	10
CCP400YC ★	4	100	4.5	114.3	10
CCP500YC ★	5	125	5.562	141.3	EA

★ Made in USA

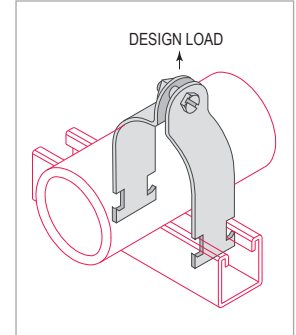

CLUTCH CLAMPS

- For tube and EMT conduit.

Part #	Tube Size O.D.		Box Qty
	O.D.	in	
CLT025 ★	1/4	0.25	10
CLT037 ★	3/8	0.375	50
CLT050 ★	1/2	0.5	50
CLT062 ★	5/8	0.625	50
CLT075 ★	3/4	0.75	50
CLT087 ★	7/8	0.875	50
CLT112 ★	1 1/8	1.125	50

Part #	EMT SIZE		Box Qty
	O.D.	in	
CLE050 ★	1/2	0.706	50
CLE075 ★	3/4	0.922	50
CLE100 ★	1	1.163	50

★ Made in USA

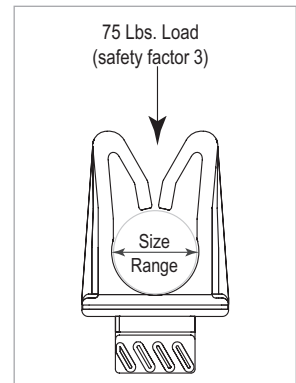

- Holes are 3/16 diameter, 13/16 center to edge on 1 1/8 centers unless specified

SQUARE WASHER

- Standard finish is Yellow Zinc Dichromate.

Part #	Bolt Size		Hole Size		Box Qty
	in	mm	in	mm	
SW025EG ★	1/4	6	5/16	7.9	100
SW031EG ★	5/16	7	3/8	9.5	100
SW037EG ★	3/8	8	7/16	11.1	100
SW050EG ★	1/2	12	9/16	14.3	100
SW062EG ★	5/8	16	1 1/16	17.5	100
SW075EG ★	3/4	20	1 3/16	20.6	100
SW087EG ★	7/8	22	1 5/16	23.8	100

★ Made in USA

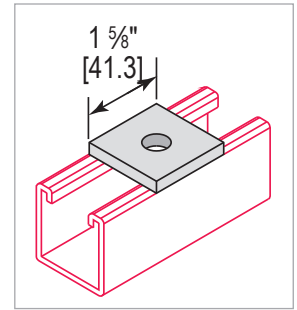

SQUARE WASHER - NOTCHED

- Standard finish is Zinc Electroplate.

Part #	Bolt Size		Box Qty
	in	mm	
SWN025EG ★	1/4	6	100
SWN037EG ★	3/8	8	100
SWN050EG ★	1/2	12	100
SWN062EG ★	5/8	16	100
SWN075EG ★	3/4	20	100

★ Made in USA

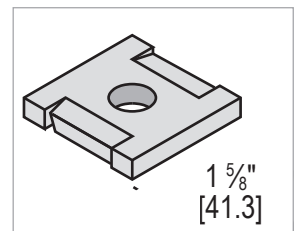

5 HOLE CROSS PLATE

- Standard finish is Zinc Electroplate.

Part #	Box Qty
XP5HEG ★	50

★ Made in USA

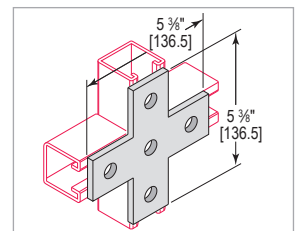

7 HOLE CROSS GUSSET PLATE

- Standard finish is Zinc Electroplate.

Part #	Box Qty
XGP7HEG ★	25

★ Made in USA

- Holes are 9/16 diameter, 1 3/16 center to edge on 1 7/8 centers unless specified

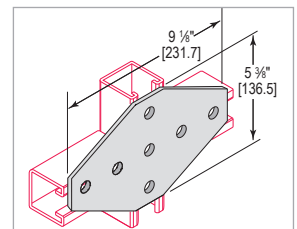

2 HOLE SPLICE PLATE

- Standard finish is Zinc Electroplate.

Part #	Box Qty
SP2HEG ★	50

★ Made in USA

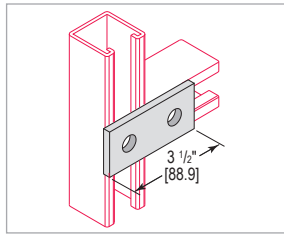

3 HOLE SPLICE PLATE

- Standard finish is Zinc Electroplate.

Part #	Box Qty
SP3HEG ★	25

★ Made in USA

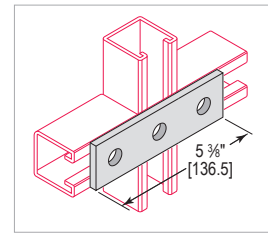

4 HOLE SPLICE PLATE

- Standard finish is Zinc Electroplate.

Part #	Box Qty
SP4HEG ★	25

★ Made in USA

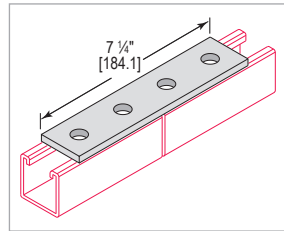

5 HOLE SPLICE PLATE

- Standard finish is Zinc Electroplate.

Part #	Box Qty
SP5HEG ★	25

★ Made in USA

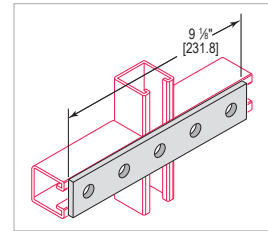

2 HOLE SPLICE PLATE PARALLEL

- Standard finish is Zinc Electroplate.

Part #	Box Qty
SPP2HEG ★	50

★ Made in USA

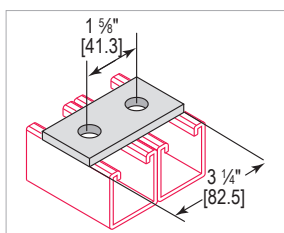

4 HOLE SPLICE PLATE PARALLEL

- Standard finish is Zinc Electroplate.

Part #	Box Qty
SPP4HEG ★	25

★ Made in USA

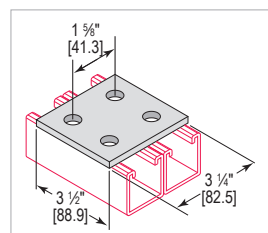

• Holes are 5/16 diameter, 13/16 center to edge on 1/8 centers unless specified

2 HOLE SPLICE SWIVEL PLATE

- Standard finish is Zinc Electroplate.

Part #	Box Qty
SWP2HEG ★	25

★ Made in USA

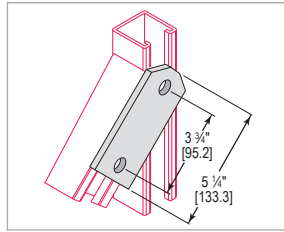

3 HOLE SPLICE PLATE

- Standard finish is Zinc Electroplate.

Part #	Box Qty
SWP3HEG ★	25

★ Made in USA

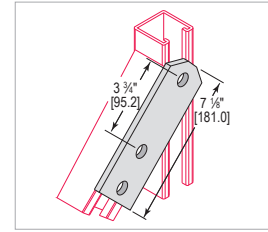

3 HOLE CORNER PLATE

- Standard finish is Zinc Electroplate.

Part #	Box Qty
CP3HEG ★	25

★ Made in USA

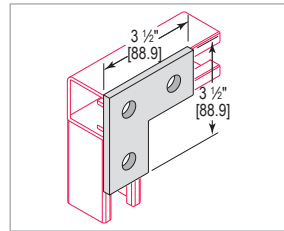

4 HOLE CORNER PLATE

- Standard finish is Zinc Electroplate.

Part #	Box Qty
CP4HEG ★	20

★ Made in USA

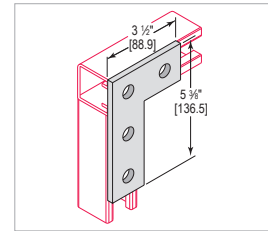

3 HOLE CORNER GUSSET PLATE

- Standard finish is Zinc Electroplate.

Part #	Box Qty
CGP3HEG ★	25

★ Made in USA

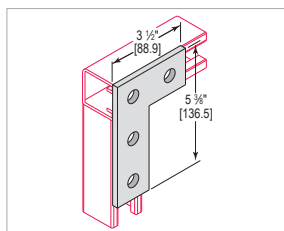

4 HOLE CORNER GUSSET PLATE

- Standard finish is Zinc Electroplate.

Part #	Box Qty
CGP4HEG ★	15

★ Made in USA

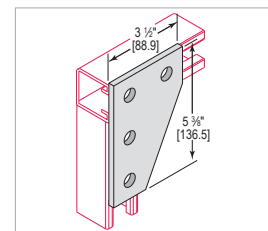

• Holes are 3/16 diameter, 13/16 center to edge on 1/8 centers unless specified

5 HOLE CORNER GUSSET PLATE

- Standard finish is Zinc Electroplate.

Part #	Box Qty
CGP5HEG ★	10

★ Made in USA

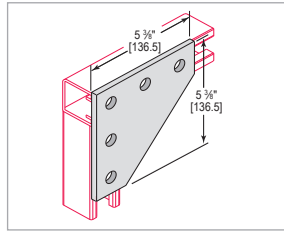

4 HOLE TEE PLATE

- Standard finish is Zinc Electroplate.

Part #	Box Qty
TP4HEG ★	20

★ Made in USA

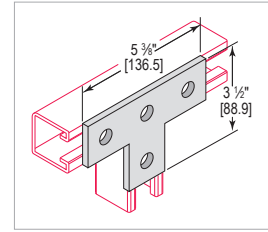

3 HOLE TEE GUSSET PLATE

- Standard finish is Zinc Electroplate.

Part #	Box Qty
TGP3HEG ★	25

★ Made in USA

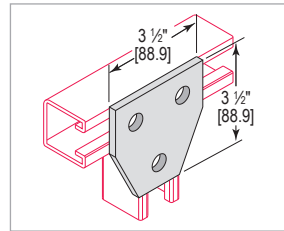

4 HOLE TEE GUSSET PLATE

- Standard finish is Zinc Electroplate.

Part #	Box Qty
TGP4HEG ★	20

★ Made in USA

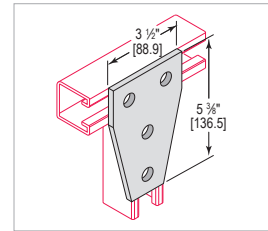

5 HOLE TEE GUSSET PLATE

- Standard finish is Zinc Electroplate.

Part #	Box Qty
TGP5HEG ★	10

★ Made in USA

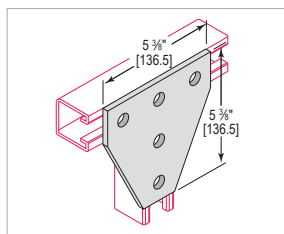

• Holes are 9/16 diameter, 13/16 center to edge on 1 1/8 centers unless specified

2 HOLE NO TWIST CORNER ANGLE

- Standard finish is Zinc Electroplate.

Part #	Box Qty
CANT2HEG ★	50

★ Made in USA

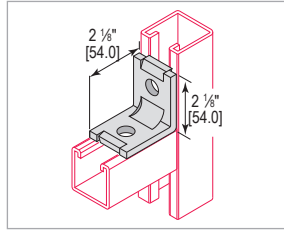

2 HOLE CORNER ANGLE

- Standard finish is Zinc Electroplate.

Part #	Box Qty
CA2HEG ★	50

★ Made in USA

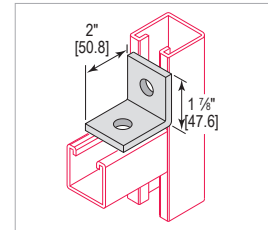

3 HOLE CORNER ANGLE

- Standard finish is Zinc Electroplate.

Part #	Box Qty
CA3HEG ★	25

★ Made in USA

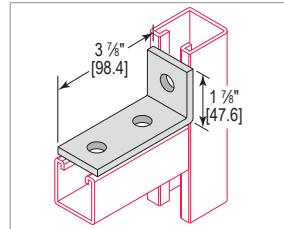

4 HOLE CORNER ANGLE

- Standard finish is Zinc Electroplate.

Part #	Box Qty
CA4HEG ★	25

★ Made in USA

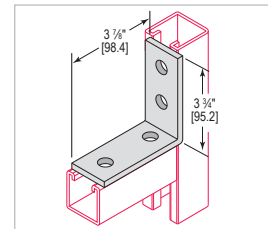

2 HOLE 3" CORNER ANGLE

- Standard finish is Zinc Electroplate.

Part #	Box Qty
CA2H3LEG ★	25

★ Made in USA

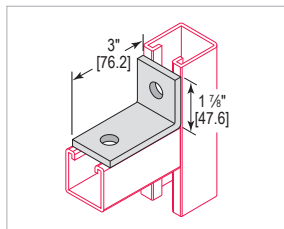

2 HOLE 3-1/2" CORNER ANGLE

- Standard finish is Zinc Electroplate.

Part #	Box Qty
CA2H350LEG ★	25

★ Made in USA

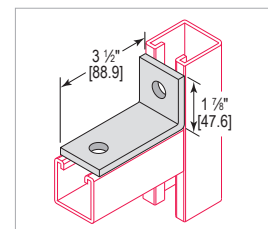

• Holes are 1/16 diameter, 13/16 center to edge on 1 1/8 centers unless specified

2 HOLE 4" CORNER ANGLE

- Standard finish is Zinc Electroplate.

Part #	Box Qty
CA2H4LEG ★	25

★ Made in USA

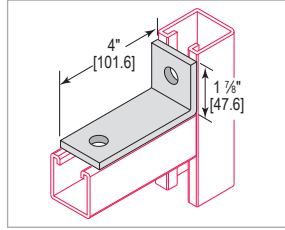

2 HOLE CROSS CORNER ANGLE

- Standard finish is Zinc Electroplate.

Part #	Box Qty
CAX2HEG ★	50

★ Made in USA

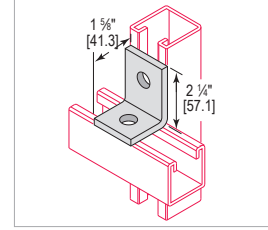

3 HOLE CORNER ANGLE

- Standard finish is Zinc Electroplate.

Part #	Box Qty
CA3HLEG ★	25

★ Made in USA

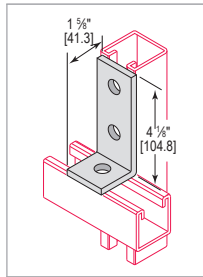

3 HOLE CROSS GUSSET CORNER ANGLE

- Standard finish is Zinc Electroplate.

Part #	Box Qty
CAGX3HEG ★	25

★ Made in USA

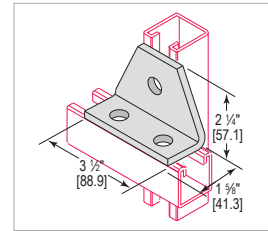

• Holes are 1/16 diameter, 13/16 center to edge on 1/8 centers unless specified

5 HOLE CROSS GUSSET CORNER ANGLE

- Standard finish is Zinc Electroplate.

Part #	Box Qty
CAGX5HEG ★	20

★ Made in USA

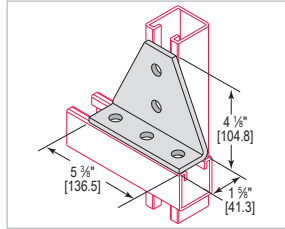

4 HOLE ANGLE

- Standard finish is Zinc Electroplate.

Part #	Box Qty
CAP4HEG ★	20

★ Made in USA

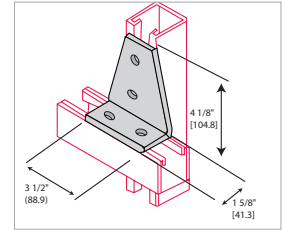

3 HOLE 3 WAY CORNER ANGLE

- Standard finish is Zinc Electroplate.

Part #	Box Qty
CA3H3WEG ★	25

★ Made in USA

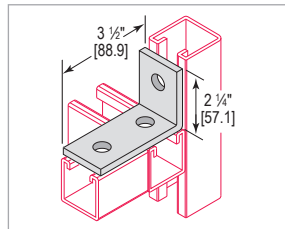

4 HOLE 3 WAY CORNER ANGLE

- Standard finish is Zinc Electroplate.

Part #	Box Qty
CA4H3WEG ★	25

★ Made in USA

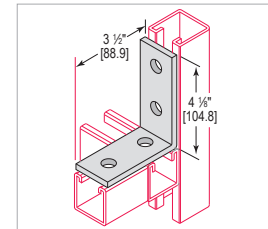

- Holes are $\frac{9}{16}$ diameter, $\frac{13}{16}$ center to edge on $\frac{1}{8}$ centers unless specified

4 HOLE 3 WAY GUSSET CORNER ANGLE

- Standard finish is Zinc Electroplate.

Part #	Box Qty
CAG4H3WEG ★	10

★ Made in USA

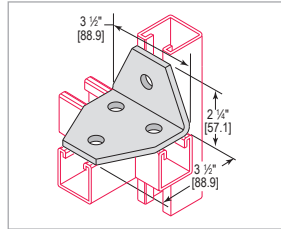

5 HOLE 3 WAY GUSSET CORNER ANGLE

- Standard finish is Zinc Electroplate.

Part #	Box Qty
CAG5H3WEG ★	10

★ Made in USA

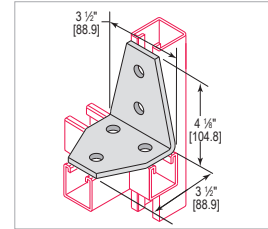

7 HOLE UNIVERSAL GUSSET CORNER ANGLE

- Standard finish is Zinc Electroplate.

Part #	Box Qty
CAUG7HEG ★	20

★ Made in USA

- Standard finish is Zinc Electroplate.

Part #	Box Qty
CAGL4HEG ★	10

★ Made in USA

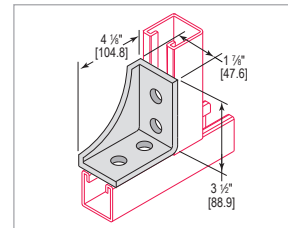

• Holes are 3/16 diameter, 13/16 center to edge on 1 1/8 centers unless specified

**4 HOLE GUSSET
CORNER ANGLE RIGHT**

- Standard finish is Zinc Electroplate.

Part #	Box Qty
CAGR4HEG ★	10

★ Made in USA

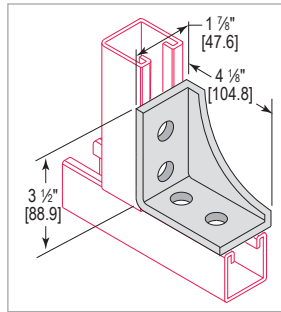

**2 HOLE 2-5/8\" ADJUSTABLE
CORNER ANGLE**

- Standard finish is Zinc Electroplate.

Part #	Box Qty
CAA2H262EG ★	25

★ Made in USA

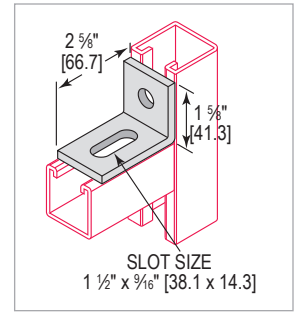

**2 HOLE 4-7/8\" ADJUSTABLE
CORNER ANGLE**

- Standard finish is Zinc Electroplate.

Part #	Box Qty
CAA2H487EG ★	25

★ Made in USA

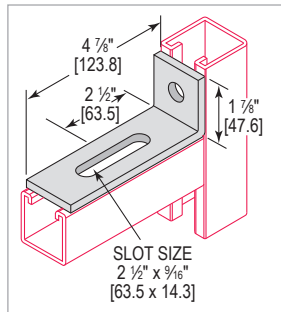

**2 HOLE 6-7/8\" ADJUSTABLE
CORNER ANGLE**

- Standard finish is Zinc Electroplate.

Part #	Box Qty
CAA2H687EG ★	25

★ Made in USA

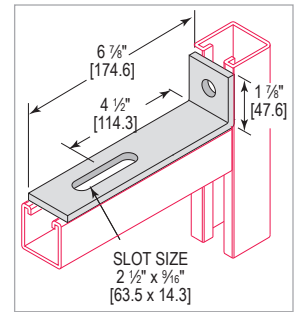

**3 HOLE ADJUSTABLE
CORNER ANGLE**

- Standard finish is Zinc Electroplate.

Part #	Box Qty
CAA3H262EG ★	25

★ Made in USA

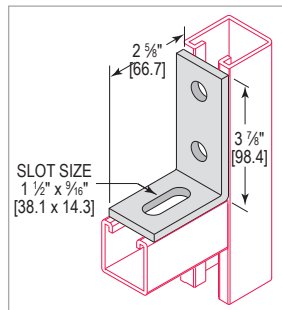

**2 HOLE ADJUSTABLE
GUSSET CORNER ANGLE**

- Standard finish is Zinc Electroplate.

Part #	Box Qty
CAAG2HEG ★	20

★ Made in USA

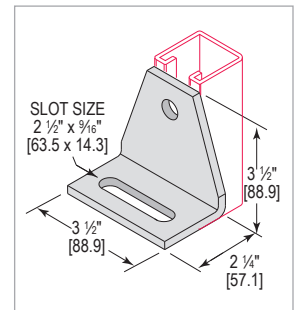

• Holes are 3/16 diameter, 13/16 center to edge on 1/8 centers unless specified

4 HOLE ADJUSTABLE GUSSET CORNER ANGLE

- Standard finish is Zinc Electroplate.

Part #	Box Qty
CAAG4H662EG ★	10

★ Made in USA

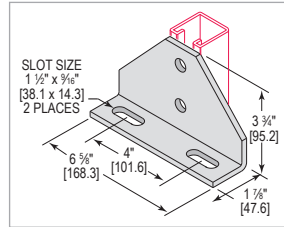

4 HOLE ADJUSTABLE CORNER ANGLE

- Standard finish is Zinc Electroplate.

Part #	Box Qty
CAA4H862EG ★	10

★ Made in USA

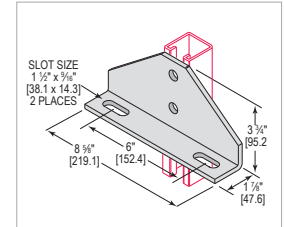

4 HOLE OFFSET CORNER ANGLE

- Standard finish is Zinc Electroplate.

Part #	Box Qty
CAOFF4HEG ★	25

★ Made in USA

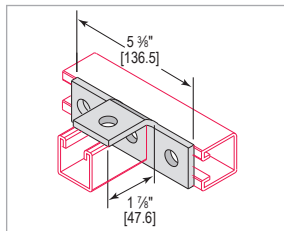

4 HOLE OFFSET BENT TEE (LEFT HAND)

- Standard finish is Zinc Electroplate.

Part #	Box Qty
CAOFF4HLEG ★	25

★ Made in USA

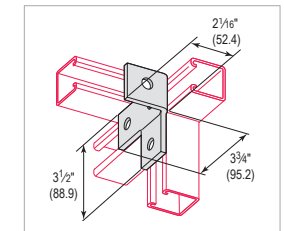

4 HOLE OFFSET BENT TEE (RIGHT HAND)

- Standard finish is Zinc Electroplate.

Part #	Box Qty
CAOFF4HREG ★	25

★ Made in USA

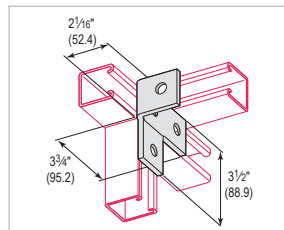

4 HOLE 45° CORNER ANGLE

- Standard finish is Zinc Electroplate.
- "A" is available in any angle up to 90°
- Dimensions shown may vary based on specified angle "A"

Part #	Box Qty
CAO4H45EG ★	25

★ Made in USA

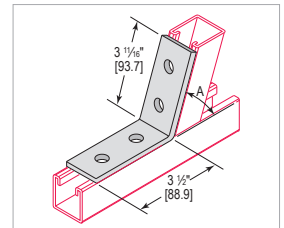

2 HOLE OPEN 45° CORNER ANGLE

- Standard finish is Zinc Electroplate.
- "A" is available in any angle up to 90°
- Dimensions shown may vary based on specified angle "A"

Part #	Box Qty
CAO2H45EG ★	25

★ Made in USA

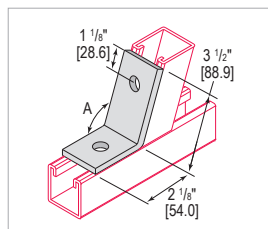

• Holes are 9/16 diameter, 13/16 center to edge on 1/8 centers unless specified

2 HOLE CLOSED 45° CORNER ANGLE

- Standard finish is Zinc Electroplate.
- "A" is available in any angle up to 90°
- Dimensions shown may vary based on specified angle "A"

Part #	Box Qty
CAC2H45EG ★	25

★ Made in USA

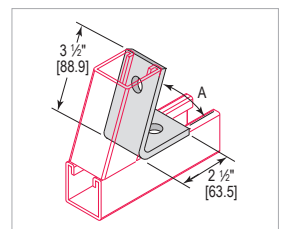

4 HOLE CLOSED 45° CORNER ANGLE

- Standard finish is Zinc Electroplate.
- "A" is available in any angle up to 90°
- Dimensions shown may vary based on specified angle "A"

Part #	Box Qty
CAC4H45EG ★	25

★ Made in USA

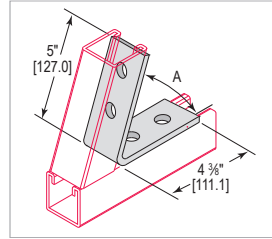

4 HOLE ADJUSTABLE CORNER ANGLE

- Standard finish is Zinc Electroplate.

Part #	Box Qty
CAA4HEG ★	25

★ Made in USA

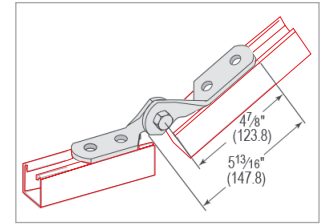

3 HOLE ADJUSTABLE CORNER ANGLE

- Standard finish is Zinc Electroplate.

Part #	Box Qty
CAA3H50EG ★	25

★ Made in USA

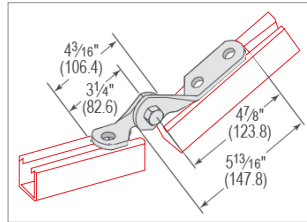

1 HOLE 3-7/8" CORNER ANGLE

- Standard finish is Zinc Electroplate.

Part #	Box Qty
CA1H387EG ★	50

★ Made in USA

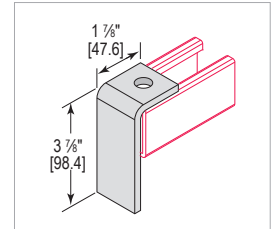

1 HOLE 5-7/8" CORNER ANGLE

- Standard finish is Zinc Electroplate.

Part #	Box Qty
CA1H587EG ★	25

★ Made in USA

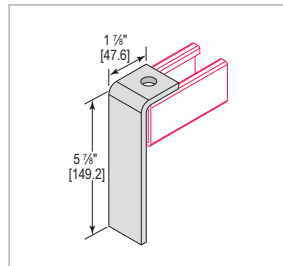

1 HOLE 7-7/8" CORNER ANGLE

- Standard finish is Zinc Electroplate.

Part #	Box Qty
CA1H787EG ★	25

★ Made in USA

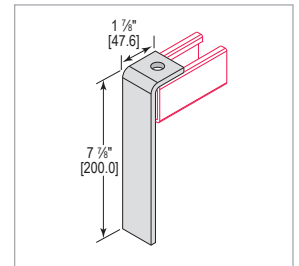

1 HOLE 9-7/8" CORNER ANGLE

- Standard finish is Zinc Electroplate.

Part #	Box Qty
CA1H987EG ★	25

★ Made in USA

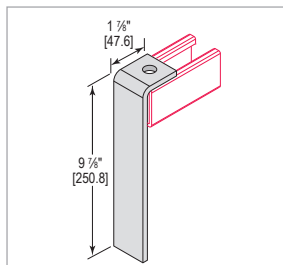

- Holes are 9/16 diameter, 13/16 center to edge on 1 7/8 centers unless specified

8" ANGLE BRACE

- Standard finish is Zinc Electroplate.

Part #	Box Qty
AB8EG ★	EA

★ Made in USA

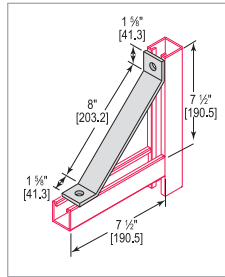

12" ANGLE BRACE

- Standard finish is Zinc Electroplate.

Part #	Box Qty
AB12EG ★	EA

★ Made in USA

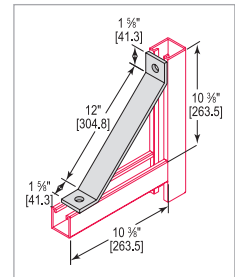

16" ANGLE BRACE

- Standard finish is Zinc Electroplate.

Part #	Box Qty
AB16EG ★	EA

★ Made in USA

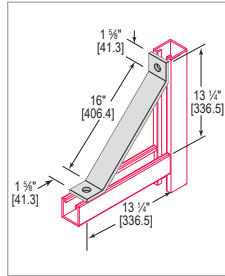

18" ANGLE BRACE

- Standard finish is Zinc Electroplate.

Part #	Box Qty
AB18EG ★	EA

★ Made in USA

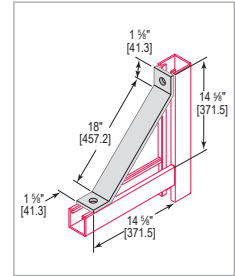

24" ANGLE BRACE

- Standard finish is Zinc Electroplate.

Part #	Box Qty
AB24EG ★	EA

★ Made in USA

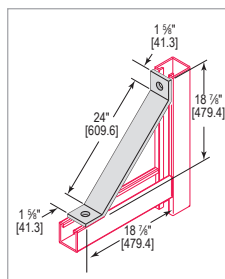

BEAM CLAMP FORMED STEEL

- Standard finish is Zinc Electroplate.

Part #	Design Load				Box Qty
	Position A		Position B		
	lbs.	kN	lbs.	kN	
BC075EG ★	500	2.22	300	1.33	25

★ Made in USA

- Maximum rod size 1/2".
- Maximum flange thickness 3/4".

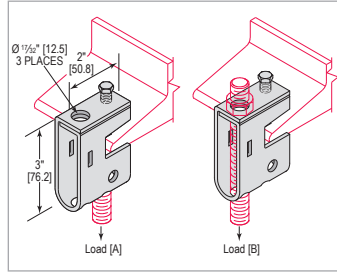

BEAM CLAMP WITH J HOOK

- Standard finish is Zinc Electroplate.

Part #	W		Box Qty
	Position A		
	in	mm.	
BCJH036EG ★	3 - 6	76 - 152	25
BCJH069EG ★	6 - 9	152 - 228	25
BCJH912EG ★	9 - 12	228 - 305	25

★ Made in USA

- Maximum rod size 1/2".
- Maximum flange thickness 3/4".
- Design Loads same as BC075EG, Formed Steel.

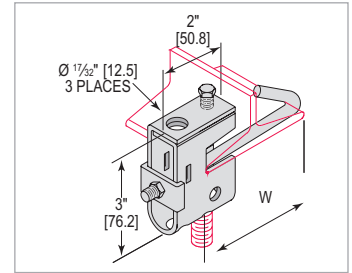

BEAM CLAMP ANCHOR STRAP

- Standard finish is Zinc Electroplate.
- For beam flange greater than 3/4" (19mm) thick use next larger flange width size.

Part #	W* (max)		L		Box Qty
	in	mm	in	mm	
BCAS6EG ★	6	228	9	152	50
BCAS9EG ★	9	305	12	228	50
BCAS12EG ★	12	381	15	305	50
BCAS15EG ★	15	457	18	381	50

★ Made in USA

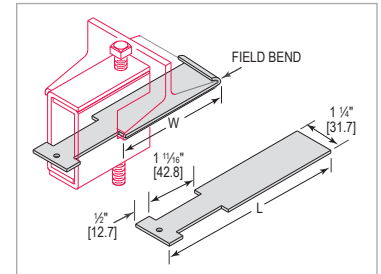

BEAM CLAMP SWIVEL ADAPTER

- Adapter for BC075EG.
- Standard finish is Zinc Electroplate.
- For use with 1/4", 3/8" or 1/2" rod.
- Design load is 500 lbs (2.22 kN).

Part #	Box Qty
BCSA ★	25

★ Made in USA

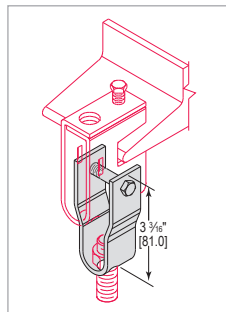

FORMED STEEL BEAM CLAMP

- Standard finish is Zinc Electroplate.

Part #	Rod Size	Set Screw	Design Load		Box Qty
			lbs.	kN	
BC3787EG ★	3/8"	3/8"-16"	650	2.89	20
BC5087EG ★	1/2"	1/2"-13"	1,100	2.89	20

★ Made in USA

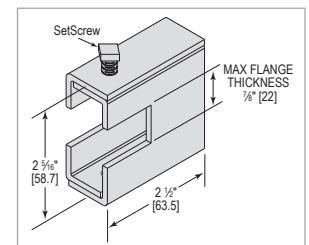

FORMED STEEL HEAVY DUTY BEAM CLAMP

- Standard finish is Zinc Electroplate.

Part #	Rod Size	Set Screw	Design Load		Box Qty
	in		lbs.	kN	
BCHD3787EG ★	3/8	1/2"-13"	1100	4.89	20
BCHD5087EG ★	1/2	1/2"-13"	1100	4.89	20
BCHD6287EG ★	5/8	1/2"-13"	1100	4.89	20

★ Made in USA

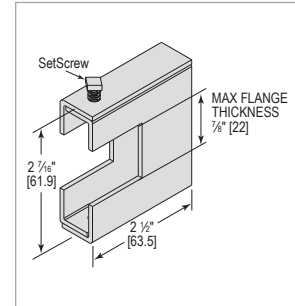

FORMED STEEL HEAVY DUTY BEAM CLAMP

- Standard finish is Zinc Electroplate.

Part #	Rod Size	Set Screw	Design Load		Box Qty
	in		lbs.	kN	
BCHD37162EG ★	3/8	1/2"-13"	1100	4.89	20
BCHD50162EG ★	1/2	1/2"-13"	1100	4.89	20
BCHD62162EG ★	5/8	1/2"-13"	1100	4.89	20

★ Made in USA

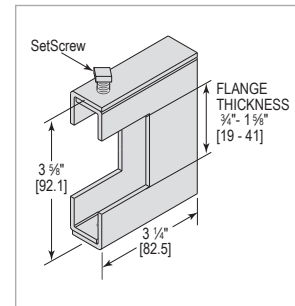

BEAM CLAMP TO STRUT C-TYPE

- Standard finish is Zinc Electroplate.

Part #	Set Screw	Material Thickness		Design Load		Box Qty
		in	mm	lbs.	kN	
BCSC251EG ★	3/8"-16"	1/4	6.3	550	2.45	25
BCSC371EG ★	1/2"-13"	3/8	9.5	1000	4.45	25

★ Made in USA

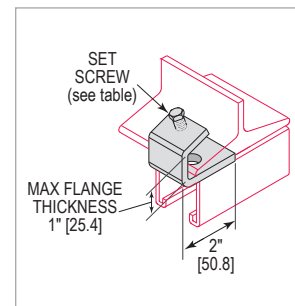

STRUT FITTINGS

BEAM CLAMP TO STRUT C-TYPE PARALLEL

- Standard finish is Zinc Electroplate.
- 3/8" material thickness.
- Design load 1000 lbs when used in pairs.

Part #	Box Qty
BCSCP37250EG ★	25

★ Made in USA

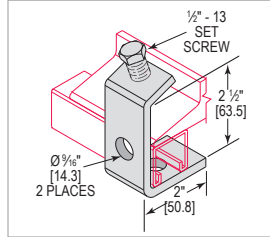

BEAM CLAMP TO STRUT Z-TYPE

- Standard finish is Zinc Electroplate.
- 3/8" material thickness.
- Design load 600 lbs when used in pairs.

Part #	Box Qty
BCSZ371EG ★	25

★ Made in USA

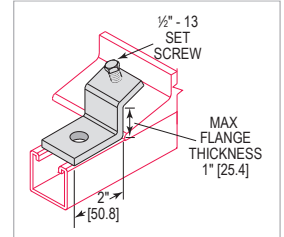

BEAM CLAMP TO STRUT WINDOW TYPE

- Standard finish is Zinc Electroplate.
- Design load 950 lbs when used in pairs.

Part #	Box Qty
BCSW ★	25

★ Made in USA

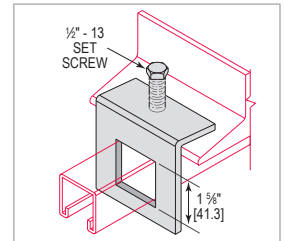

BEAM CLAMP TO STRUT SPREADER CAPS

- Standard finish is Zinc Electroplate.
- Design load 1000 lbs (2.22kN) when used as a set.
- Use with 12 gauge strut; cut strut length 1-1/4" to 1-5/8" shorter than the average distance between flanges (Dimension "A").
- Includes two adjustable caps.

Part #	Box Qty
BCSSCDHDEG ★	25

★ Made in USA

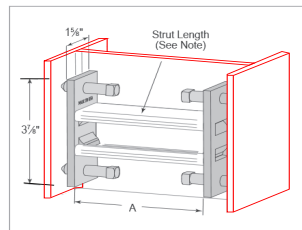

- Standard finish is Zinc Electroplate.
- Design load 500 lbs (2.22kN) when used as a set.
- Use with 12 gauge strut; cut strut length 1-1/4" to 1-5/8" shorter than the average distance between flanges (Dimension "A").
- Includes one adjustable cap and one nonadjustable cap.

Part #	Box Qty
BCSSCEG ★	25

★ Made in USA

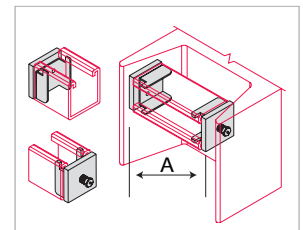

BEAM CLAMP TO STRUT WITH U-BOLT

- Standard finish is Zinc Electroplate.
- For 1-3/16" and 1-5/8" channel.
- For use with flanges up to 3/4" [19.1] thick.
- Design load 1200 lbs (5.34 kN) when used in pairs.

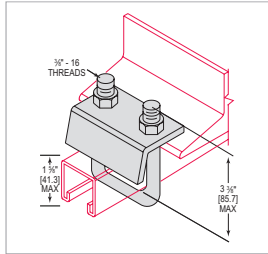

Part #	Box Qty
BCSU162EG ★	25

★ Made in USA

- Standard finish is Zinc Electroplate.
- For 2-7/16" and 3-1/4" channel.
- For use with flanges up to 3/4" [19.1] thick.
- Design load 1200 lbs (5.34 kN) when used in pairs.

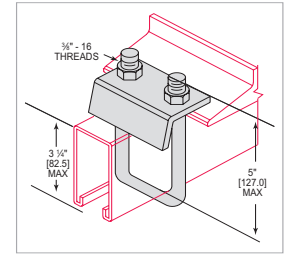

Part #	Box Qty
BCSU325EG ★	25

★ Made in USA

BEAM CLAMP TO STRUT WITH SQUARE U-BOLT AND J-HOOK

- Standard finish is Zinc Electroplate.
- For 1-3/16" and 1-5/8" channel.
- For use with flanges up to 3/4" [19.1] thick.

Part #	W		Box Qty
	in	mm	
BCSUJ162SEG ★	4 to 6	101 to 152	25
BCSUJ162MEG ★	6 to 9	152 to 228	25
BCSUJ162LEG ★	9 to 12	228 to 302	25

★ Made in USA

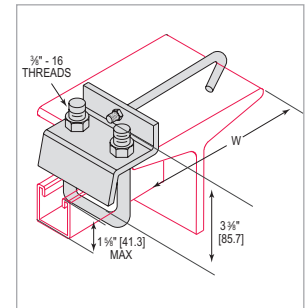

- Standard finish is Zinc Electroplate.
- For 2-7/8" and 3-1/4" channel.
- For use with flanges up to 3/4" [19.1] thick.

Part #	W		Box Qty
	in	mm	
BCSUJ325SEG ★	4 to 6	101 to 152	25
BCSUJ325MEG ★	6 to 9	152 to 228	25
BCSUJ325LEG ★	9 to 12	228 to 302	25

★ Made in USA

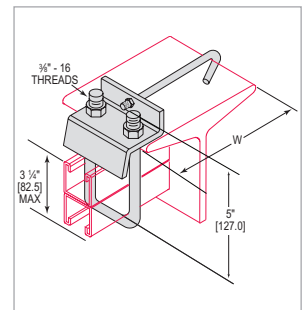

BEAM CLAMP TO STRUT DOUBLE

- Standard finish is Zinc Electroplate.
- Double for 1³/₁₆" & 1-⁵/₈" channel.
- For use with flanges up to $\frac{3}{4}$ " [1.91] thick.

Part #	Box Qty
BCSD162EG ★	25

★ Made in USA

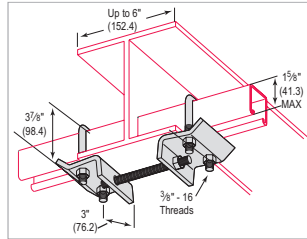

- Standard finish is Zinc Electroplate.
- Double for 2-⁷/₁₆" & 3-¹/₄" channel.
- For use with flanges up to $\frac{3}{4}$ " [1.91] thick.

Part #	Box Qty
BCSD325EG ★	25

★ Made in USA

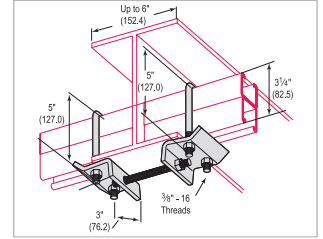

BEAM CLAMP TO STRUT WITH U-BOLT

- Standard finish is Zinc Electroplate.
- For use with flanges up to $\frac{3}{4}$ " [1.91] thick.

Part #	Box Qty
BCSU650EG ★	25

★ Made in USA

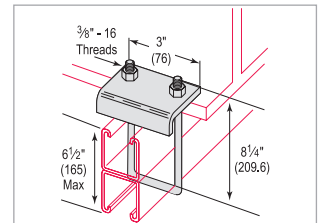

BEAM CLAMP TO STRUT NOTCHED TYPE

- Standard finish is Zinc Electroplate.
- Material is 1-⁵/₈" wide x $\frac{1}{4}$ " thick.
- Clamp requires $\frac{1}{2}$ "-13 HCS and $\frac{1}{2}$ " channel nut.
- Design load 1100 lbs (4.89 kN) when used in pairs.

Part #	Box Qty
BCSNTEG ★	50

★ Made in USA

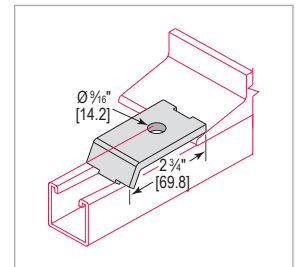

MALLEABLE IRON UNIVERSAL BEAM CLAMP

Part #	Rod Size	Max Load		Max Pipe Size		Box Qty
		lbs.	kN	in	mm	
BCUM37PL*	3/8"-16	350	1.56	4	100	100
BCUM37EG*	3/8"-16	350	1.56	4	100	100
BCUM50PL*	1/2"-13	470	2.09	4	100	100
BCUM50EG*	1/2"-13	470	2.09	4	100	100
BCUM62PL*	5/8"-11	550	2.45	5	125	50
BCUM62EG*	5/8"-11	550	2.45	5	125	50
BCUM75PL*	3/4"-10	700	3.11	6	150	50
BCUM75EG*	3/4"-10	700	3.11	6	150	50

Part #	B		L		H		D	
	in	mm	in	mm	in	mm	in	mm
BCUM37PL*	7/8	22.2	1-5/16	33.3	1-1/2	38.1	1/2	12.7
BCUM37EG*	7/8	22.2	1-5/16	33.3	1-1/2	38.1	1/2	12.7
BCUM50PL*	7/8	22.2	1-5/16	33.3	1-1/2	38.1	1/2	12.7
BCUM50EG*	7/8	22.2	1-5/16	33.3	1-1/2	38.1	1/2	12.7
BCUM62PL*	1-1/8	28.6	1-3/4	44.5	1-3/4	44.5	5/8	15.9
BCUM62EG*	1-1/8	28.6	1-3/4	44.5	1-3/4	44.5	5/8	15.9
BCUM75PL*	1-1/8	34.9	1-7/8	44.5	1-7/8	47.6	5/8	15.9
BCUM75EG*	1-1/8	34.9	1-7/8	44.5	1-7/8	47.6	5/8	15.9

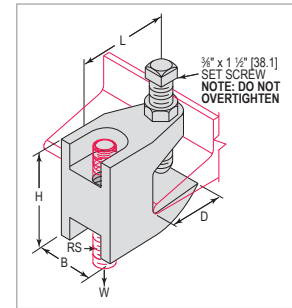

- Standard finish is Zinc Electroplate and Plain.
- Maximum flange thickness of 5/8".
- *Import Item, Call for domestic availability.

WIDE MOUTH MALLEABLE IRON C-CLAMP WITH LOCK NUT

Part #	Rod Size	Max Load		Max Pipe Size		Box Qty
		lbs.	kN	in	mm	
BCUMW37PL*	3/8"-16	400	1.78	4	100	60
BCUMW37EG*	3/8"-16	400	1.78	4	100	60
BCUMW50PL*	1/2"-13	500	2.22	4	100	60
BCUMW50EG*	1/2"-13	500	2.22	4	100	60
BCUMW62PL*	5/8"-11	500	2.22	4	100	40
BCUMW62EG*	5/8"-11	500	2.22	4	100	40

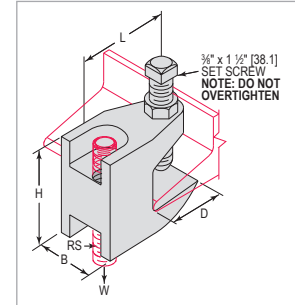

Part #	B		L		H		D	
	in	mm	in	mm	in	mm	in	mm
BCUMW37PL*	7/8	22.2	1-3/8	34.9	2	50.8	1/2	12.7
BCUMW37EG*	7/8	22.2	1-3/8	34.9	2	50.8	1/2	12.7
BCUMW50PL*	7/8	22.2	1-3/8	34.9	2	50.8	1/2	12.7
BCUMW50EG*	7/8	22.2	1-3/8	34.9	2	50.8	1/2	12.7
BCUMW62PL*	1-1/4	31.8	1-7/8	47.6	2-3/8	60.3	5/8	15.9
BCUMW62EG*	1-1/4	31.8	1-7/8	47.6	2-3/8	60.3	5/8	15.9

- Standard finish is Zinc Electroplate and Plain.
- Maximum flange thickness of 1-1/16".
- *Import Item, Call for domestic availability

MALLEABLE IRON C-CLAMP WITH LOCK NUT

Part #	Rod Size	Dim. "B"	Design Load		Box Qty
			lbs.	kN	
BCMC37PL*	3/8"-16"	1-3/4"	400	1.8	100
BCMC37EG*	3/8"-16"	1-3/4"	400	1.8	100
BCMC50PL*	1/2"-13"	1-3/4"	400	1.8	125
BCMC50EG*	1/2"-13"	1-3/4"	400	1.8	125
BCMC62PL*	5/8"-11"	2"	450	2	60
BCMC62EG*	5/8"-11"	2"	450	2	60

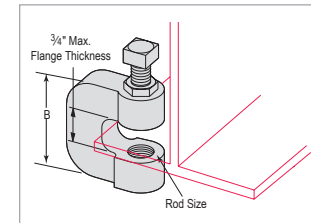

- Standard finish is Zinc Electroplate and Plain.
- *Import Item, Call for domestic availability

MALLEABLE IRON UNIVERSAL BEAM CLAMP

- Standard finish is Zinc Electroplate.
- Maximum flange thickness $\frac{5}{8}$ ".
- *Import Item, Call for domestic availability.

Part #	Rod Size	Max Load W1		Max Load W2		Box Qty
		lbs.	kN	lbs.	kN	
BCUBM25EG*	¼"-20"	100	0.44	250	1.11	100

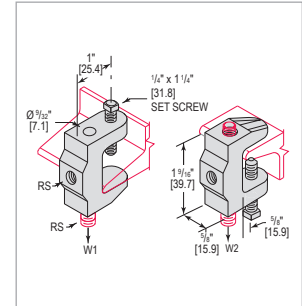

RIGHT ANGLE CLAMP

- Standard finish is Hot-Dip Galvanized.
- *Import Item, Call for domestic availability.

Part #	Paper Size		Box Qty
	in	mm	
RAC050HDG*	½	15	50
RAC075HDG*	¾	20	50
RAC100HDG*	1	25	50
RAC125HDG*	1-¼	32	50
RAC150HDG*	1-½	40	50
RAC200HDG*	2	50	50
RAC250HDG*	2-½	65	25
RAC300HDG*	3	80	10
RAC350HDG*	3-½	90	10
RAC400HDG*	4	100	10

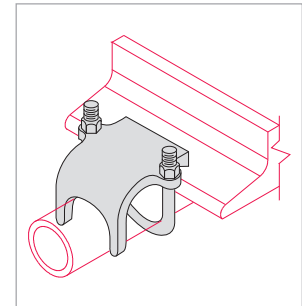

STRUT FITTINGS

SLOTTED SHELF BRACKET LEFT HAND

- Standard finish is Zinc Electroplate.
- Uniform load rating 250 lbs (1.11 kN) when mounted on 12 gauge channel.

Part #	L		H		Box Qty
	in	mm	in	mm	
BRSSL6EG ★	6	152.4	2-7/8	73	EA
BRSSL8EG ★	8	203.2	2-7/8	73	EA
BRSSL10EG ★	10	254	2-7/8	73	EA
BRSSL12EG ★	12	304.8	3-7/16	87.3	EA
BRSSL14EG ★	14	355.6	3-15/16	100	EA
BRSSL16EG ★	16	406.4	4-7/16	112.7	EA
BRSSL18EG ★	18	457.2	4-15/16	125.4	EA

★ Made in USA

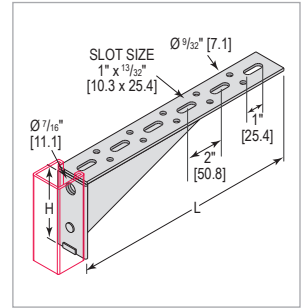

SLOTTED SHELF BRACKET RIGHT HAND

- Standard finish is Zinc Electroplate.
- Uniform load rating 250 lbs (1.11 kN) when mounted on 12 gauge channel.

Part #	L		H		Box Qty
	in	mm	in	mm	
BRSSR6EG ★	6	152.4	2-7/8	73	EA
BRSSR8EG ★	8	203.2	2-7/8	73	EA
BRSSR10EG ★	10	254	2-7/8	73	EA
BRSSR12EG ★	12	304.8	3-7/16	87.3	EA
BRSSR14EG ★	14	355.6	3-15/16	100	EA
BRSSR16EG ★	16	406.4	4-7/16	112.7	EA
BRSSR18EG ★	18	457.2	4-15/16	125.4	EA

★ Made in USA

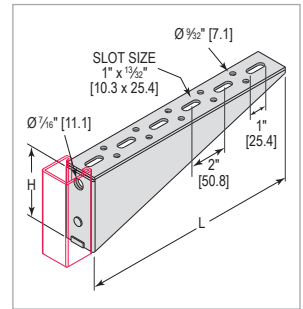

BRACKET 3 HOLE

- Standard finish is Zinc Electroplate.
- *When mounted on 12 gauge channel.

Part #	L		Uniform Load*		Box Qty
	in	mm	lbs.	kN	
BR3H0850EG ★	8-1/2	215.9	850	3.78	EA
BR3H1050EG ★	10-1/2	266.7	8.50	3.78	EA

★ Made in USA

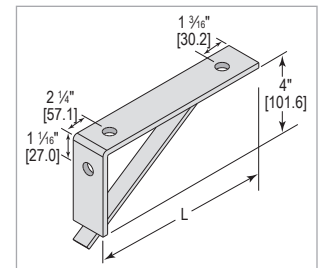

BRACKET 6 HOLE

- Standard finish is Zinc Electroplate.
- *When mounted on 12 gauge channel.

Part #	L		A		Uniform Load*		Box Qty
	in	mm	in	mm	lbs.	kN	
BR6H1250EG ★	12-½	317.5	3-¾	95.2	900	4	EA
BR6H1450EG ★	14-½	368.3	5-¾	146	900	4	EA

★ Made in USA

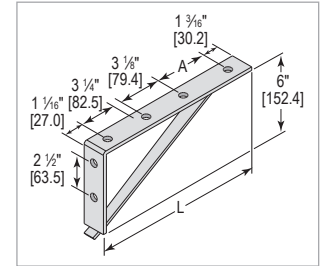

BRACKET WITH BRACE 6 HOLE

- Standard finish is Zinc Electroplate.
- *When mounted on 12 gauge channel.

Part #	L		A		B		Uniform Load*		Box Qty
	in	mm	in	mm	in	mm	lbs.	kN	
BRB6H1650EG ★	16-½	419.1	5-¼	133.3	5-¾	146	1200	5.34	EA
BRB6H1850EG ★	18-½	469.9	5-¼	133.3	7-¾	196.8	1100	4.89	EA
BRB6H2050EG ★	20-½	520.7	7-¼	184.1	7-¾	196.8	900	4	EA

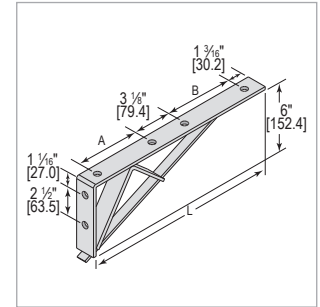

STRUT FITTINGS

BRACKET FOR 1-5/8" CHANNEL

- Standard finish is Zinc Electroplate.
- Maximum loading 5800 in. lb. (655 Nm) when mounted on 12 gauge channel.
- Max load applies to bracket only, not the strength of the strut arm.

Part #	Box Qty
BRC162EG ★	EA

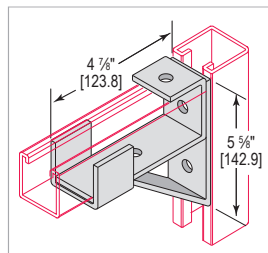

BRACKET FOR 3-1/4" CHANNEL

- Standard finish is Zinc Electroplate.
- Maximum loading 12500 in. lb. (1412 Nm) when mounted on 12 gauge channel.
- Max load applies to bracket only, not the strength of the strut arm.

Part #	Box Qty
BRC325EG ★	EA

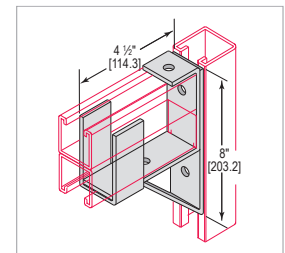

BRACKET CHANNEL FOR 1-5/8" CHANNEL 2 HOLE

- Standard finish is Zinc Electroplate.
- *When mounted on 12 gauge channel.

Part #	L		Uniform Load*		Box Qty
	in	mm	lbs.	kN	
BRC1626EG ★	6	152.4	1250	5.56	EA
BRC1629EG ★	9	228.6	1000	4.45	EA
BRC16212EG ★	12	304.8	750	3.34	EA
BRC16218EG ★	18	457.2	500	2.22	EA
BRC16224EG ★	24	609.6	350	1.56	EA

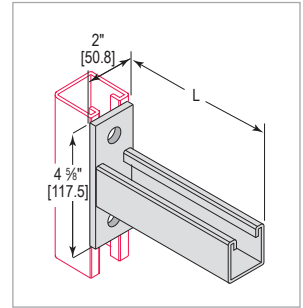

BRACKET CHANNEL WRAP AROUND 1-5/8" CHANNEL

- Standard finish is Zinc Electroplate.
- *When mounted on 12 gauge channel.

Part #	L		Uniform Load*		Box Qty
	in	mm	lbs.	kN	
BRC162W6EG ★	6	152.4	1250	5.56	EA
BRC162W12EG ★	12	304.8	1000	4.45	EA
BRC162W18EG ★	18	457.2	750	3.34	EA
BRC162W24EG ★	24	609.6	500	2.22	EA

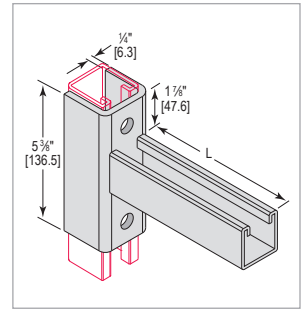

BRACKET CHANNEL FOR 1-5/8" CHANNEL 2 HOLE

- Standard finish is Zinc Electroplate.
- *When mounted on 12 gauge channel.

Part #	L		Uniform Load*		Box Qty
	in	mm	lbs.	kN	
BRC162D12EG ★	12	304.8	1800	8.01	EA
BRC162D18EG ★	18	457.2	1200	5.34	EA
BRC162D24EG ★	24	609.6	1000	4.45	EA
BRC162D30EG ★	30	762	800	3.56	EA
BRC162D36EG ★	36	914.4	660	2.94	EA

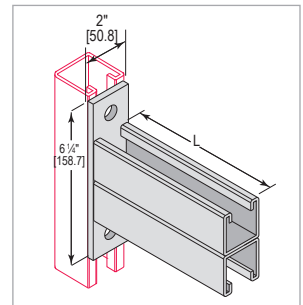

BRACKET CHANNEL NOTCHED UP

- Standard finish is Zinc Electroplate.
- *When mounted on 12 gauge channel.

Part #	L		Uniform Load*		Box Qty
	in	mm	lbs.	kN	
BRC162NU6EG ★	6	152.4	1250	5.56	EA
BRC162NU9EG ★	9	228.6	1000	4.45	EA
BRC162NU12EG ★	12	304.8	750	3.34	EA
BRC162NU18EG ★	18	457.2	500	2.22	EA
BRC162NU24EG ★	24	609.6	350	1.56	EA

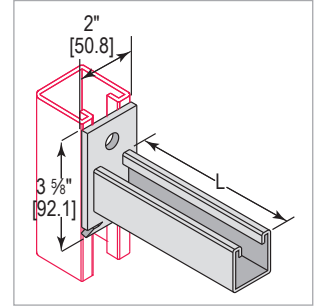

BRACKET CHANNEL NOTCHED DOWN

- Standard finish is Zinc Electroplate.
- *When mounted on 12 gauge channel.

Part #	L		Uniform Load*		Box Qty
	in	mm	lbs.	kN	
BRC162ND6EG ★	6	152.4	1250	5.56	EA
BRC162ND9EG ★	9	228.6	1000	4.45	EA
BRC162ND12EG ★	12	304.8	750	3.34	EA
BRC162ND18EG ★	18	457.2	500	2.22	EA
BRC162ND24EG ★	24	609.6	350	1.56	EA

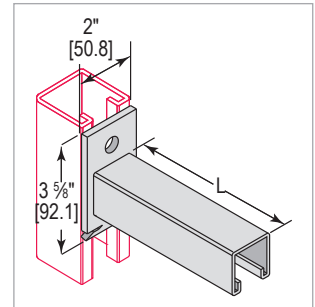

BRACKET CHANNEL HEAVY DUTY

- Standard finish is Zinc Electroplate.
- *When mounted on 12 gauge channel.

Part #	L		H		Uniform Load*		Box Qty
	in	mm	in	mm	lbs.	kN	
BRC162B12EG ★	12	304.8	8-3/4	222.2	1450	6.45	EA
BRC162B18EG ★	18	457.2	8-3/4	222.2	900	4	EA
BRC162B24EG ★	24	609.6	8-3/4	222.2	900	4	EA
BRC162B30EG ★	30	762	11-1/4	285.7	800	3.56	EA
BRC162B36EG ★	36	914.4	11-1/4	285.7	750	3.34	EA

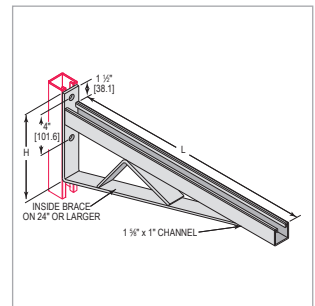

STRUT FITTINGS

LADDER BRACKET

- Standard finish is Zinc Electroplate.
- Material is 1-5/8" (41.3) wide x 1/4" (6.3) thick.
- Hole centers are 13/16" (20.6) from edge on 1-7/8" (47.6) centers.

Part #	B	L	Box Qty
	in	in	
BRL0237EG ★	2-3/8	6	20
BRL0437EG ★	4-3/8	8	20
BRL0637EG ★	6-3/8	10	20
BRL0837EG ★	8-3/8	12	20
BRL1037EG ★	10-3/8	14	EA

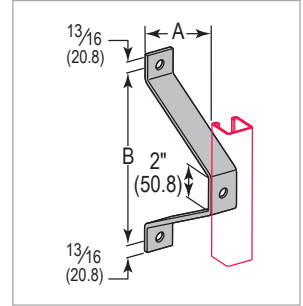

CONCRETE INSERT

- Standard finish is Yellow Zinc Electroplate.

Part #	Design Load		Box Qty
	lbs.	kN	
CIEG ★	600	2.67	25
CIPL ★	600	2.67	25

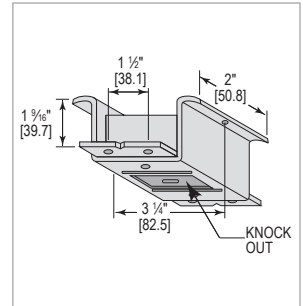

CONCRETE INSERT NUT

- Standard finish is Zinc Electroplate and Plain.

Part #	RS Rod Size	T Thickness	Box Qty	Part #	RS Rod Size	T Thickness	Box Qty
CIN25PL ★	1/4"-20"	1/4"	100	CIN25EG ★	1/4"-20"	1/4"	100
CIN37PL ★	3/8"-16"	1/4"	100	CIN37EG ★	3/8"-16"	1/4"	100
CIN50PL ★	1/2"-13"	5/16"	100	CIN50EG ★	1/2"-13"	5/16"	100
CIN62PL ★	5/8"-11"	5/16"	100	CIN62EG ★	5/8"-11"	5/16"	100
CIN75PL ★	3/4"-10"	1/2"	100	CIN75EG ★	3/4"-10"	1/2"	100
CIN87PL ★	7/8"-9"	1/2"	100	CIN87EG ★	7/8"-9"	1/2"	100

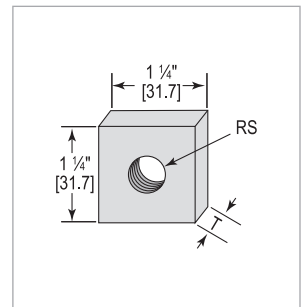

PLASTIC END CAP

Part #	For Use w/ Channel	Color	Box Qty
ECP81W ★	1-5/8" x 13/16"	White	100
ECP81R ★	1-5/8" x 13/16"	Red	100
ECP162W ★	1-5/8" x 1-5/8"	White	100
ECP162R ★	1-5/8" x 1-5/8"	Red	100
ECP325W ★	1-5/8" x 3-1/4"	White	100
ECP325R ★	1-5/8" x 3-1/4"	Red	100

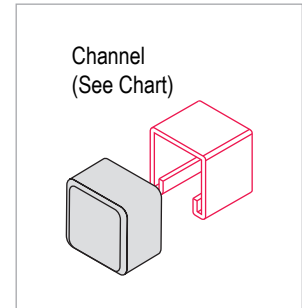

★ Made in USA

END CAPS

- Standard finish is Zinc Electroplate.
- For 1-5/8" 12 gauge channel.

Part #	Box Qty
EC16212GAEG ★	100

★ Made in USA

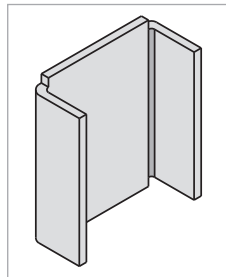

- Standard finish is Zinc Electroplate.
- For 1-5/8" 14 gauge channel.

Part #	Box Qty
EC16214GAEG ★	100

★ Made in USA

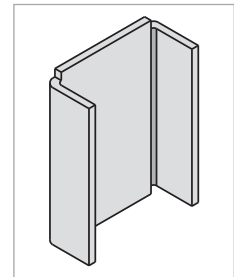

- Standard finish is Zinc Electroplate.
- For 13/16" 14 gauge channel.

Part #	Box Qty
EC8114GAEG ★	100

★ Made in USA

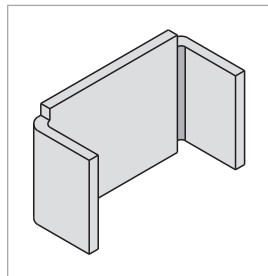

HINGED FLUORESCENT FIXTURE HANGING

- Standard finish is Zinc Electroplate.
- For 1-5/8" channel 9/16" hole.
- Maximum loading 120 lbs. (0.53 kN).

Part #	Box Qty
FH16256EG ★	20

★ Made in USA

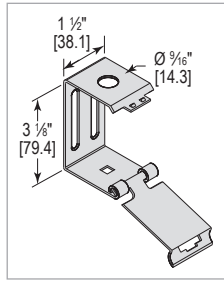

- Standard finish is Zinc Electroplate.
- For 3-1/4" channel 9/16" hole.
- Maximum loading 120 lbs. (0.53 kN).

Part #	Box Qty
FH32556EG ★	10

★ Made in USA

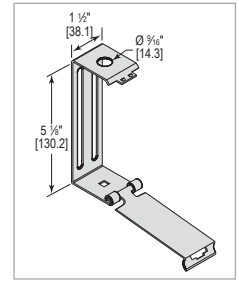

- Standard finish is Zinc Electroplate.
- For 1-5/8" channel 7/8" hole.
- Maximum loading 120 lbs. (0.53 kN).

Part #	Box Qty
FH16287EG ★	20

★ Made in USA

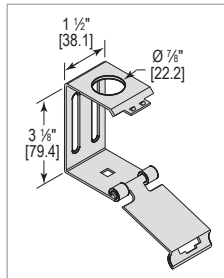

- Standard finish is Zinc Electroplate.
- For 3-1/4" channel 7/8" hole.
- Maximum loading 120 lbs. (0.53 kN).

Part #	Box Qty
FH32587EG ★	10

★ Made in USA

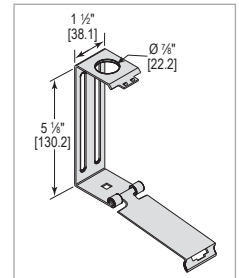

FIXTURE STUD NUT

- Standard finish is Zinc Electroplate.

Part #	Box Qty
FSD ★	100

★ Made in USA

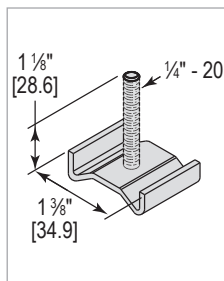

WIRING STUD

- Standard finish is Zinc Electroplate.

Part #	Box Qty
WS ★	20

★ Made in USA

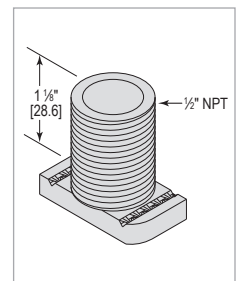

END CAP KNOCKOUT WITH HARDWARE

- Standard finish is Zinc Electroplate.
- Includes:
 - Qty 1 - FSD Fixture Stud Nut
 - Qty 1 - 1/4 - 20 Square Nut

Part #	ØA		Box Qty
	in	mm	
ECK050EG ★	1/2	12.7	25
ECK075EG ★	3/4	19	25

★ Made in USA

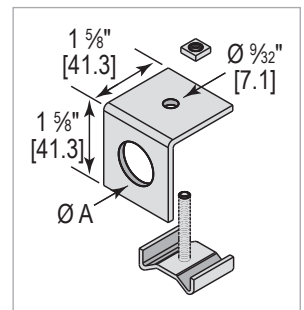

CONDUIT CONNECTION PLATE WITH HARDWARE

- Standard finish is Zinc Electroplate.
- Includes:
Qty 2 - CNN025EG Channel Nuts
Qty 2 - 1/4 - 20 Flat Head Machine Screws

Part #	Conduit Size		Box Qty
	in	mm	
CPC50EG ★	1/2	12.7	25
CPC75EG ★	3/4	19	25

★ Made in USA

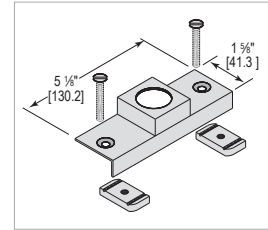

CHANNEL SPLICE ASSEMBLY - TAPPED

- Standard finish is Zinc Electroplate.
- 4 hole assembly.
- Includes tapped plate and hardware.

Part #	Box Qty
CSA4HTPEG ★	20

★ Made in USA

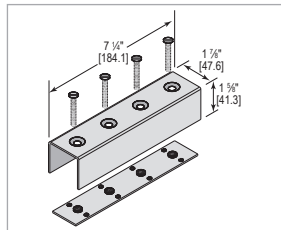

CHANNEL SPLICE ASSEMBLY - STUD

- Standard finish is Zinc Electroplate.
- 4 hole assembly.
- Includes tapped plate and hardware.

Part #	Box Qty
CSA4HSPEG ★	20

★ Made in USA

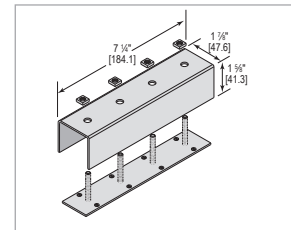

INSIDE STRUT JOINER

- Standard finish is Zinc Electroplate.

Part #	For Use with Channel	Box Qty
SJ181EG ★	1 3/16"	20
SJ162EG ★	1 - 5/8"	20

★ Made in USA

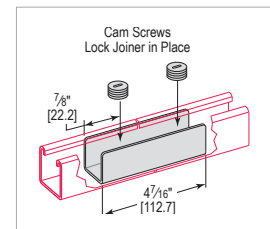

OUTLET BOLT WITH HARDWARE

- Standard finish is Zinc Electroplate.
- Includes:
Qty 2 - CNN025EG Channel Nuts
Qty 2 - 1/4 - 20 Flat Head Machine Screws

Part #	Box Qty
OBBD ★	20

★ Made in USA

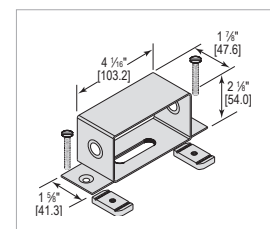

JUNCTION BOX UNIVERSAL WITH 1 CONNECT

- Standard finish is Zinc Electroplate.
- Includes:
 - Qty 1 - ECK075EG
 - Qty 1 - 3/4" - Bushing with Nut

Part #	Box Qty
JBU1EG ★	EA

★ Made in USA

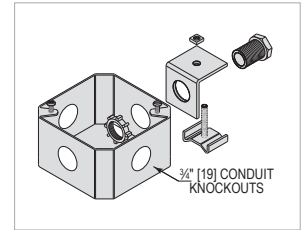

JUNCTION BOX UNIVERSAL WITH 2 CONNECT

- Standard finish is Zinc Electroplate.
- Connectors at 90°
- Includes:
 - Qty 2 - ECK075EG
 - Qty 2 - 3/4" - Bushing with Nut

Part #	Box Qty
JBU290EG ★	EA

★ Made in USA

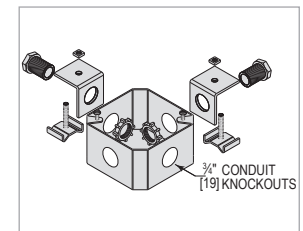

JUNCTION BOX UNIVERSAL WITH 2 CONNECT

- Standard finish is Zinc Electroplate.
- Connects at opposite sides.
- Includes:
 - Qty 2 - ECK075EG
 - Qty 2 - 3/4" - Bushing with Nut

Part #	Box Qty
JBU20EG ★	EA

★ Made in USA

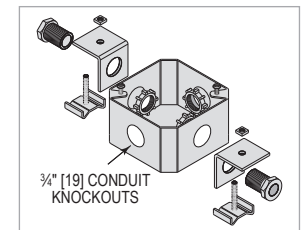

JUNCTION BOX UNIVERSAL WITH 3 CONNECT

- Standard finish is Zinc Electroplate.
- Includes:
 - Qty 3 - ECK075EG
 - Qty 3 - 3/4" - Bushing with Nut

Part #	Box Qty
JBU3EG ★	20

★ Made in USA

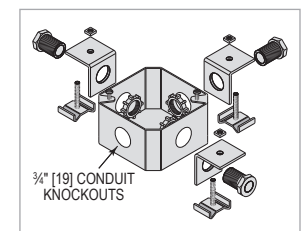

POST BASE SINGLE CHANNEL

- Standard finish is Zinc Electroplate.
- 2 Hole Square 3-1/2"

Part #	Box Qty
PBS2H350SQEG ★	5

★ Made in USA

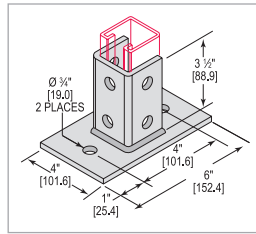

- Standard finish is Zinc Electroplate.
- 2 Hole Square Flush 3-1/2"

Part #	Box Qty
PBS2H350FLEG ★	5

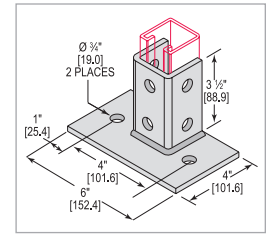

- Standard finish is Zinc Electroplate.
- 4 Hole Standard 1-5/8"

Part #	Box Qty
PBS4H162EG ★	5

★ Made in USA

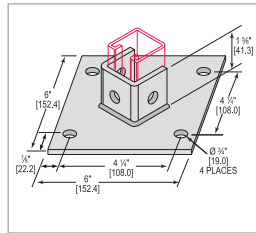

- Standard finish is Zinc Electroplate.
- 4 Hole Standard 3-1/2"

Part #	Box Qty
PBS4H350EG ★	5

★ Made in USA

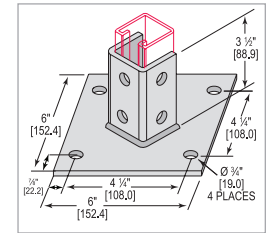

- Standard finish is Zinc Electroplate.
- 4 Hole Square 3-1/2"

Part #	Box Qty
PBS4H350SQEG ★	5

★ Made in USA

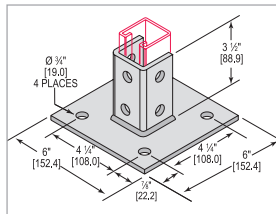

- Standard finish is Zinc Electroplate.
- 4 Hole Square 3-1/2"

Part #	Box Qty
PBSG4H350SQEG ★	5

★ Made in USA

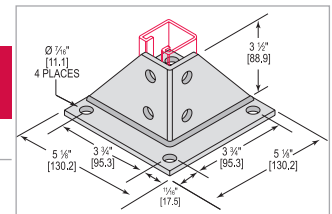

- Standard finish is Zinc Electroplate.
- 2 Hole Flush 1-5/8"

Part #	Box Qty
PBS2H162FLEG ★	25

★ Made in USA

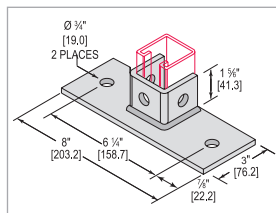

- Standard finish is Zinc Electroplate.
- 4 Hole Square 1-5/8"

Part #	Box Qty
PBS4H162SQEG ★	5

★ Made in USA

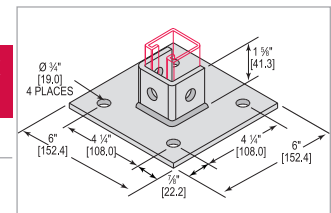

POST BASE SINGLE CHANNEL

- Standard finish is Zinc Electroplate.
- 2 Hole Square Flush 3-1/2".

Part #	Box Qty
PBS2H350SQFLEG ★	5

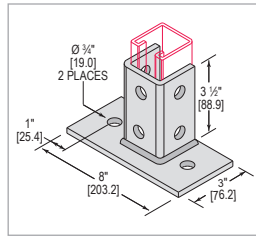

POST BASE DOUBLE CHANNEL

- Standard finish is Zinc Electroplate.
- 1 Hole 1-5/8".

Part #	Box Qty
PBD1H162EG ★	5

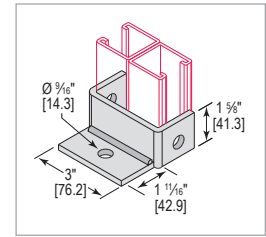

POST BASE DOUBLE CHANNEL

- Standard finish is Zinc Electroplate.
- 2 Hole Square 3-1/2" Boxed.

Part #	Box Qty
PBD2H350SQBEG ★	5

★ Made in USA

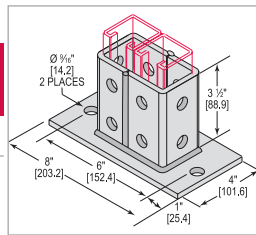

- Standard finish is Zinc Electroplate.
- 4 Hole Standard 1-5/8"."

Part #	Box Qty
PBD4H162EG ★	5

★ Made in USA

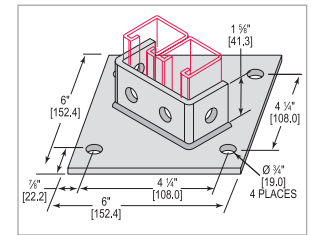

- Standard finish is Zinc Electroplate.
- 4 Hole Square 3-1/2".

Part #	Box Qty
PBD4H350EG ★	5

★ Made in USA

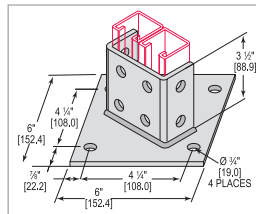

- Standard finish is Zinc Electroplate.
- 4 Hole Square 3-1/2".

Part #	Box Qty
PBD4H350SQEG ★	5

★ Made in USA

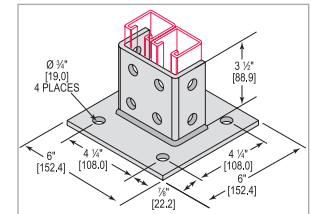

- Standard finish is Zinc Electroplate.
- 2 Hole Square Flush 3-1/2".

Part #	Box Qty
PBD2H350FLEG ★	5

★ Made in USA

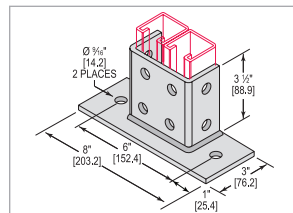

POST BASE DOUBLE CHANNEL

- Standard finish is Zinc Electroplate.
- 2 Hole Square Flush 1-5/8".

Part #	Box Qty
PBD2H162FLEG ★	5

★ Made in USA

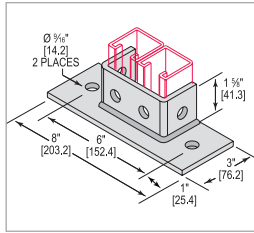

POST BASE DOUBLE CHANNEL

- Standard finish is Zinc Electroplate.
- 4 Hole Square Flush 1-5/8".

Part #	Box Qty
PBD4H162SQEG ★	5

★ Made in USA

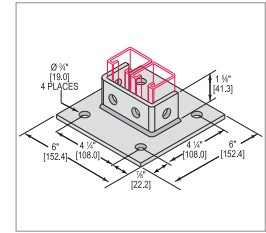

ROLLERS

**ROLLER TROLLEY
2 BEARING ASSEMBLY**

- Standard finish is Zinc Electroplate.
- Stainless steel ball bearings.
- Maximum load rating of 300 lbs. (1.33 kN).

Part #	Box Qty
RT2BAEG ★	25

★ Made in USA

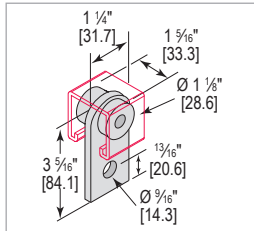

**ROLLER TROLLEY
4 BEARING ASSEMBLY**

- Standard finish is Zinc Electroplate.
- Stainless steel ball bearings.
- Maximum load rating of 600 lbs. (2.67 kN).

Part #	Box Qty
RT4BAEG ★	10

★ Made in USA

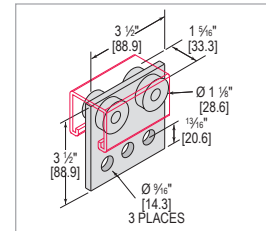

PIPE ROLLER 1" TO 4" PIPE

- Standard finish is Zinc Electroplate.
- Maximum load rating of
- 500 lbs. (2.22 kN) to 750 lbs. (3.34kN).

Part #	Box Qty
PR14EG	5

★ Made in USA

Part #	Pipe Size		Box Qty
	in	mm	
PR3740EG	3-3/4 - 4	95-102	5
PR4360EG	4-3/8 - 6	111-152	5
PR6380EG	6-3/8 - 8	162-203	5
PR9010EG	9 - 10	229-254	5

★ Made in USA

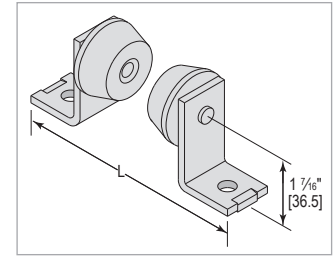

PIPE ROLLER 1" TO 4" PIPE

- Dimension information for Pipe Rollers.

Pipe Size	Pipe Covering Thickness		Actual O.D of Pipe + Shield + Insulation		Dimension L		Dimension CL	
	in	mm	in	mm	in	mm	in	mm
3/4	0	0.0	1-1/16	27.0	6-1/2	165.1	2-15/16	74.6
	1/8	22.2	3-1/4	82.6	6-1/2	165.1	4-1/8	104.8
	1-7/16	36.5	4-3/8	111.1	8-1/4	209.6	4-7/16	112.7
	1-7/8	47.6	5-3/8	136.5	8-1/4	209.6	4-15/16	125.4
	1	0.0	1-5/16	33.3	6-1/2	165.1	3-1/8	79.4
1	1-1/16	27.0	3-5/8	92.1	7-1/4	184.2	4-1/4	108.0
	1-9/16	39.7	4-5/8	117.5	8-1/4	209.6	4-9/16	115.9
	2-1/8	54.0	5-3/4	146.1	8-1/4	209.6	5-1/8	130.2
	1-1/4	0.0	1-11/16	42.9	6-1/2	165.1	3-5/16	84.1
1-1/4	7/8	22.2	3-7/8	98.4	7-1/4	184.2	4-5/16	109.5
	1-5/8	41.3	5-1/8	130.2	8-1/4	209.6	4-13/16	122.2
	1-15/16	49.2	6	152.4	8-1/4	209.6	5-1/4	133.4
	2-7/16	61.9	7-1/2	190.5	9-1/4	235.0	5-7/8	149.2
	1-1/2	0	0.0	1-7/8	47.6	6-1/2	165.1	3-3/8
1-1/2	1	25.4	4-1/4	108.0	8-1/4	209.6	4-3/8	111.1
	1-1/2	38.1	5-1/4	133.4	8-1/4	209.6	4-7/8	123.8
	2-5/16	58.7	6-5/8	168.3	8-1/4	235.0	5-7/16	138.1
	2-13/16	71.4	7-3/4	196.9	9-1/4	235.0	6	152.4
	2	0	0.0	2-3/8	60.3	6-1/2	165.1	3-11/16
2	1-1/16	27.0	4-3/4	120.7	8-1/4	209.6	4-5/8	117.5
	1-9/16	39.7	5-3/4	146.1	8-1/4	209.6	5-1/8	130.2
	2-1/8	54.0	7-1/8	181.0	9-1/4	235.0	5-11/16	144.5
	2-5/8	66.7	8-1/8	206.4	10-1/8	257.2	6-1/16	154.0
	3-1/8	79.4	9-1/8	231.8	10-1/8	257.2	6-3/8	168.3
	2-1/2	0	0.0	2-7/8	73.0	6-1/2	165.1	3-15/16
2-1/2	1-1/16	27.0	5-3/8	136.5	8-1/4	209.6	4-15/16	125.4
	1-7/8	47.6	6-5/8	168.3	9-1/4	235.0	5-7/16	138.1
	2-3/16	58.7	7-3/4	196.9	9-1/4	235.0	6	152.4
	2-7/8	73.0	8-1/2	215.9	9-1/4	235.0	6-7/16	163.5
	3-3/8	85.7	9-3/4	247.7	9-1/4	235.0	7-1/16	179.4
	3	0	0.0	6-5/8	168.3	9-1/4	235.0	5-7/16
3	1	25.4	8-1/4	209.6	10-1/8	257.2	6-1/8	155.6
	1-1/2	38.1	9-3/8	238.1	10-1/8	257.2	6-3/4	171.5
	2	50.8	10-3/8	263.5	10-7/8	276.2	7-1/8	181.0
	2-9/16	65.1	11-1/4	285.8	10-7/8	276.2	7-5/8	193.7
	3-1/16	77.8	12-3/8	314.3	10-7/8	276.2	8-1/8	206.4
	4-3/16	106.4	14-1/4	362.0	10-7/8	276.2	9-3/16	233.4
	0	0.0	6-5/8	168.3	9-1/4	235.0	5-7/16	138.1
	1	25.4	9	228.6	10-1/8	257.2	6-9/16	166.7
	1-1/2	38.1	10-1/8	257.2	10-7/8	276.2	7	177.8
	2	50.8	11	279.4	10-7/8	276.2	7-1/2	190.5
4	2-1/2	63.5	12-3/8	314.3	10-7/8	276.2	8-3/16	208.0
	3	76.2	13-1/2	342.9	10-7/8	276.2	8-9/8	219.1
	4-1/8	104.8	15-1/8	384.2	10-7/8	276.2	9-11/16	246.1
	0	0.0	8-5/8	219.1	10-1/8	257.2	6-3/8	161.9
	1-1/2	38.1	12	304.8	10-7/8	276.2	8	203.2
	2	50.8	13	330.2	10-7/8	276.2	8-9/16	217.5
	2-11/16	68.3	14-1/2	368.3	10-7/8	276.2	9-9/16	236.5
	3-1/8	79.4	15-3/8	390.5	10-7/8	276.2	9-13/16	249.2
4-13/16	106.4	17-3/8	441.3	10-7/8	276.2	10-7/8	276.2	

STRUT FITTINGS

PIPE ROLLER HD 6" TO 16" PIPE

Pipe Size	Pipe Covering Thickness		Actual O.D. of Pipe + Shield + Insulation		Dimension L		Dimension CL	
	in	mm	in	mm	in	mm	in	mm
6	0	0.0	6- ⁵ / ₈	168.3	9- ⁹ / ₁₆	236.5	7	177.8
	1	25.4	9	228.6				
	1- ¹ / ₂	38.1	10- ¹ / ₈	257.2				
	2	50.8	11	279.4				
	2- ¹ / ₂	63.5	12- ³ / ₈	314.3				
	3	76.2	13- ¹ / ₈	333.4				
8	0	0.0	8- ³ / ₈	219.1	10	254.0	7- ¹⁵ / ₁₆	201.6
	1- ¹ / ₂	38.1	12	304.8				
	2	50.8	13	330.2				
	2- ¹ / ₁₆	68.3	14- ¹ / ₂	368.3				
	3- ¹ / ₁₆	79.4	15- ³ / ₈	390.5				
	4- ³ / ₁₆	106.4	17- ³ / ₈	441.3				
10	0	0.0	10- ³ / ₄	273.1	10- ¹¹ / ₁₆	271.5	8- ¹⁵ / ₁₆	227.0
	1- ⁹ / ₁₆	39.7	14- ¹ / ₂	368.3				
	2- ¹ / ₁₆	52.4	15- ¹ / ₄	387.4				
	2- ⁹ / ₁₆	65.1	16- ¹ / ₄	412.8				
	3- ¹ / ₁₆	77.8	17- ³ / ₈	441.3				
	4- ¹ / ₁₆	103.2	19- ¹ / ₂	495.3				
12	0	0.0	12- ³ / ₄	323.9	11- ³ / ₈	288.9	9- ⁷ / ₈	250.8
	1- ⁹ / ₁₆	39.7	16- ¹ / ₈	409.6				
	2- ¹ / ₁₆	52.4	17- ¹ / ₄	438.2				
	2- ⁹ / ₁₆	66.7	18- ¹ / ₄	463.6				
	3- ¹ / ₁₆	77.8	19- ¹ / ₄	489.0				
	4- ¹ / ₁₆	104.8	20- ³ / ₈	517.5				
14	0	0.0	14	355.6	12- ¹ / ₁₆	306.4	10- ⁷ / ₁₆	265.1
	1- ¹ / ₂	38.1	17- ¹ / ₂	444.5				
	2	50.8	18- ⁵ / ₈	473.1				
	2- ¹ / ₂	63.5	19- ³ / ₄	501.7				
	3	76.2	20- ⁵ / ₈	523.9				
	4	101.6	22- ⁵ / ₈	574.7				

- Standard finish is Zinc Electroplate.
- Dimension information for PRHD616EG.
- Maximum load rating of 1,500 lbs. (6.67 kN).

Part #	Box Qty
PRHD616EG ★	5

★ Made in USA

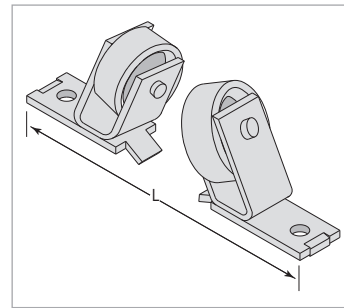

PIPE ROLLER HD 16" TO 24" PIPE

Pipe Size	Pipe Covering Thickness		Actual O.D. of Pipe + Shield + Insulation		Dimension L		Dimension CL	
	in	mm	in	mm	in	mm	in	mm
16	0	0.0	16	406.4	12- ³ / ₄	323.9	11- ³ / ₈	288.9
	1- ¹ / ₂	38.1	19- ³ / ₈	498.5				
	2	50.8	20- ³ / ₈	517.5				
	2- ¹ / ₂	63.5	21- ⁵ / ₈	549.3				
	3	76.2	22- ¹ / ₈	562.0				
	4	101.6	24- ³ / ₈	619.1				
18	0	0.0	18	457.2	12- ³ / ₄	323.9	12- ¹ / ₄	311.2
	1- ¹ / ₂	38.1	21- ⁵ / ₈	549.3				
	2	50.8	22- ³ / ₈	574.7				
	2- ¹ / ₂	63.5	23- ¹ / ₄	590.6				
	3	76.2	24- ¹ / ₄	616.0				
	4	101.6	26- ³ / ₈	676.3				
20	0	0.0	20	508.0	14- ¹ / ₈	358.8	13- ¹ / ₄	336.6
	1- ¹ / ₂	38.1	23- ¹ / ₄	590.6				
	2	50.8	24- ¹ / ₂	622.3				
	2- ¹ / ₂	63.5	25- ¹ / ₂	647.7				
	3	76.2	26- ³ / ₈	676.3				
	4	101.6	28- ¹ / ₄	717.6				
24	0	0.0	24	609.6	14- ¹³ / ₁₆	376.2	15- ¹ / ₄	387.4
	1- ¹ / ₂	38.1	27	685.8				
	2	50.8	28	711.2				
	2- ¹ / ₂	63.5	29- ¹ / ₄	743.0				
	3	76.2	30- ¹ / ₂	774.7				
	4	101.6	32- ¹ / ₈	835.0				
30	0	0.0	30	762.0	15- ³ / ₈	403.2	16- ¹ / ₄	412.8

- Standard finish is Zinc Electroplate.
- Dimension information for PRHD1624HEG.
- Maximum load rating of 2,000 lbs. (8.90 kN).

Part #	Box Qty
PRHD1624HEG ★	5

★ Made in USA

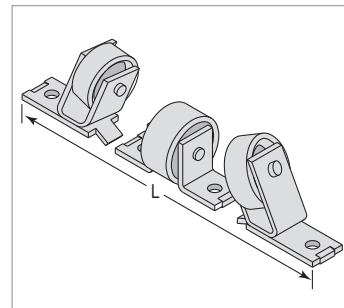

• Holes are ⁹/₁₆ diameter, ¹³/₁₆ center to edge on 1⁷/₈ centers unless specified

U-FITTING CROSS 3 HOLE 1³/₁₆"

- Standard finish is Zinc Electroplate.

Part #	Box Qty
UFX3H81EG ★	25

★ Made in USA

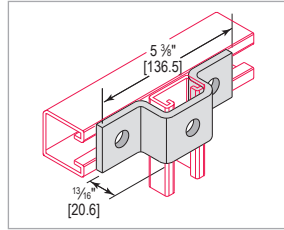

U-FITTING CROSS 5 HOLE 1-5/8"

- Standard finish is Zinc Electroplate.

Part #	Box Qty
UFX5H162EG ★	20

★ Made in USA

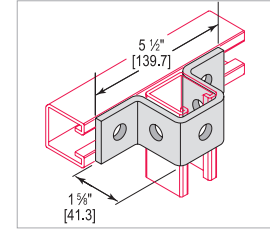

U-FITTING CROSS 3 HOLE 2-7/16"

- Standard finish is Zinc Electroplate.

Part #	Box Qty
UFX3H243EG ★	25

★ Made in USA

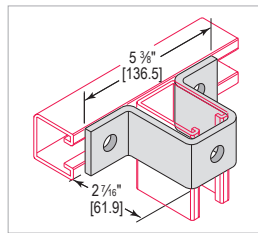

U-FITTING CROSS 3 HOLE 3-1/4"

- Standard finish is Zinc Electroplate.

Part #	Box Qty
UFX3H325EG ★	15

★ Made in USA

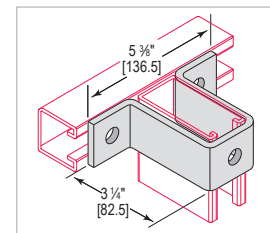

U-FITTING CROSS 3 HOLE 4-7/8"

- Standard finish is Zinc Electroplate.

Part #	Box Qty
UFX3H487EG ★	10

★ Made in USA

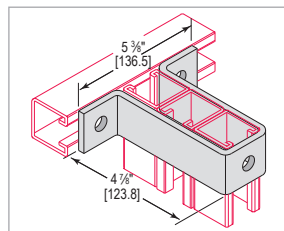

U-FITTING CROSS 8 HOLE 1-5/8"

- Standard finish is Zinc Electroplate.

Part #	Box Qty
UFX8H162EG ★	10

★ Made in USA

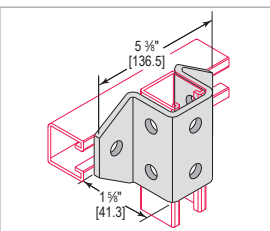

• Holes are 9/16 diameter, 13/16 center to edge on 1 7/8 centers unless specified

U-FITTING CROSS 6 HOLE

- Standard finish is Zinc Electroplate.
- For 1-5/8" Double Channel.

Part #	Box Qty
UFXD6H162EG ★	10

★ Made in USA

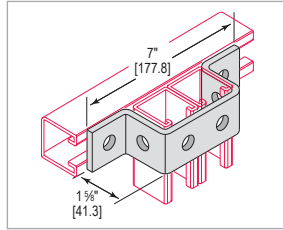

U-FITTING CROSS 1 HOLE 2 SLOT

- Standard finish is Zinc Electroplate.
- For 1-5/8" x 7-1/4" Channel.

Part #	Box Qty
UFX1H2S750EG ★	10

★ Made in USA

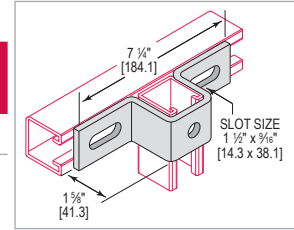

U-FITTING CROSS 1 HOLE 2 SLOT

- Standard finish is Zinc Electroplate.
- For 1-5/8" x 8-1/2" Channel.

Part #	Box Qty
UFX1H2S850EG ★	10

★ Made in USA

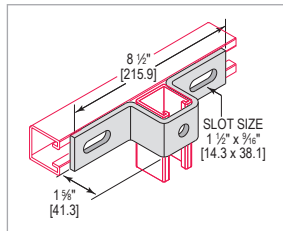

- Standard finish is Zinc Electroplate.
- For 1-5/8" x 10-1/2" Channel.

Part #	Box Qty
UFX1H2S1050EG ★	10

★ Made in USA

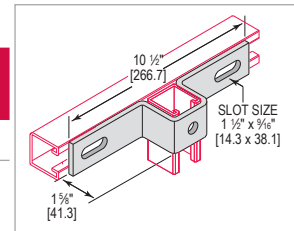

U-FITTING SPLICE 2 HOLE

- Standard finish is Zinc Electroplate.
- For 1-5/8" Channel.

Part #	Box Qty
UFS2H162EG ★	20

★ Made in USA

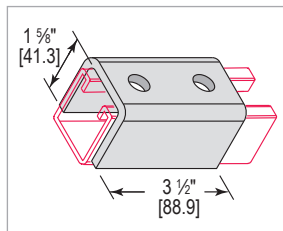

U-FITTING SPLICE 3 HOLE

- Standard finish is Zinc Electroplate.
- For 1-5/8" Channel.

Part #	Box Qty
UFS3H162EG ★	20

★ Made in USA

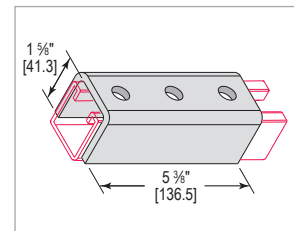

• Holes are 9/16 diameter, 13/16 center to edge on 1 1/8 centers unless specified

STRUT FITTINGS

U-FITTING SPLICE 4 HOLE

- Standard finish is Zinc Electroplate.
- For 1-5/8" Channel.

Part #	Box Qty
UFS4H162EG ★	10

★ Made in USA

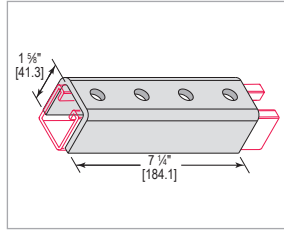

- Standard finish is Zinc Electroplate.
- For 1 3/16" Channel.

Part #	Box Qty
UFS4H81EG ★	10

★ Made in USA

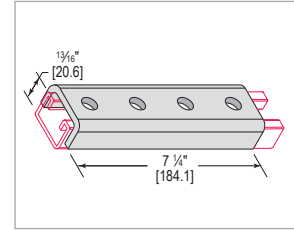

U-FITTING SPLICE 4 HOLE

- Standard finish is Zinc Electroplate.
- For 3-1/4" Channel.

Part #	Box Qty
UFS4H325EG ★	10

★ Made in USA

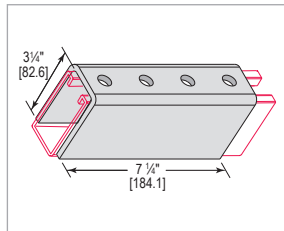

U-FITTING TROLLEY SUPPORT

- Standard finish is Zinc Electroplate.
- 3 Hole Standard.

Part #	Box Qty
UFTS3HEG ★	20

★ Made in USA

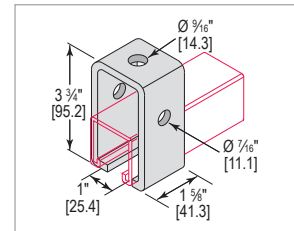

U-FITTING TROLLEY SUPPORT

- Standard finish is Zinc Electroplate.
- 3 Hole Heavy Duty.

Part #	Box Qty
UFTS3HHDEG ★	15

★ Made in USA

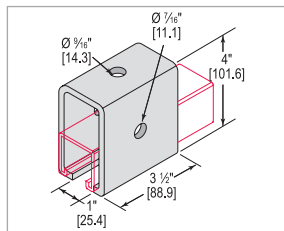

U-FITTING 4 HOLE CUP SUPPORT

- Standard finish is Zinc Electroplate.
- 4 Hole Standard.

Part #	Box Qty
UFC4HEG ★	20

★ Made in USA

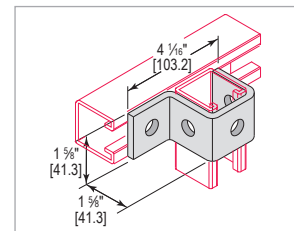

• Holes are 5/16 diameter, 13/16 center to edge on 1 7/8 centers unless specified

U-FITTING CLEVIS 2 HOLE

- Standard finish is Zinc Electroplate.

Part #	L		Box Qty
	in	mm	
UFC2H4EG ★	4	101.6	20
UFC2H5EG ★	5	127	20
UFC2H6EG ★	6	152.4	20
UFC2H7EG ★	7	177.8	20
UFC2H8EG ★	8	203.2	20

★ Made in USA

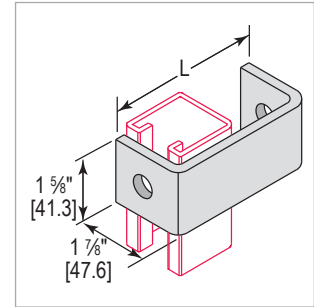

U-SHAPED WASHERS

- Standard finish is Zinc Electroplate.

Part #	Bolt Size	Hole Size (H)		Box Qty
	in	in	mm	
UW25EG ★	1/4	5/16	7.9	50
UW37EG ★	3/8	7/16	11.1	50
UW50EG ★	1/2	9/16	14.3	50
UW62EG ★	5/8	11/16	17.4	50
UW75EG ★	3/4	13/16	20.6	50

★ Made in USA

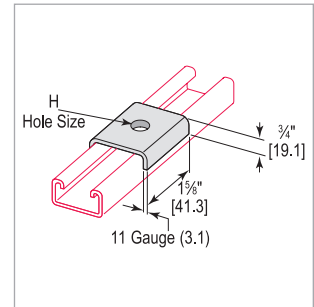

WING FITTINGS

SINGLE CORNER 2 HOLE RIGHT

- Standard finish is Zinc Electroplate.

Part #	Box Qty
WFS2HREG ★	25

★ Made in USA

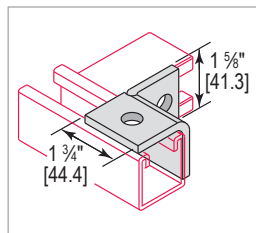

SINGLE CORNER 2 HOLE LEFT

- Standard finish is Zinc Electroplate.

Part #	Box Qty
WFS2HLEG ★	25

★ Made in USA

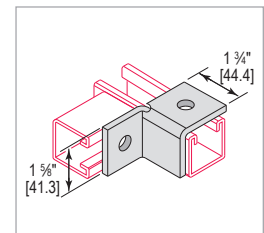

SINGLE CORNER 4 HOLE RIGHT

- Standard finish is Zinc Electroplate.
- For 3-1/4" Channel.

Part #	Box Qty
WFS4HREG ★	25

★ Made in USA

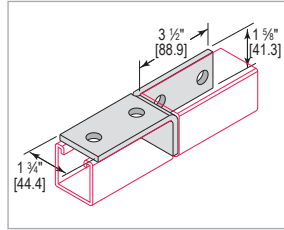

SINGLE CORNER 4 HOLE LEFT

- Standard finish is Zinc Electroplate.
- 3 Hole Standard.

Part #	Box Qty
WFS4HLEG ★	25

★ Made in USA

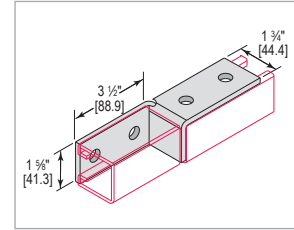

SINGLE CORNER 6 HOLE GUSSET RIGHT

- Standard finish is Zinc Electroplate.

Part #	Box Qty
WFSG6HREG ★	10

★ Made in USA

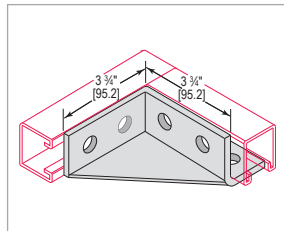

SINGLE CORNER 6 HOLE GUSSET LEFT

- Standard finish is Zinc Electroplate.

Part #	Box Qty
WFSG6HLEG ★	10

★ Made in USA

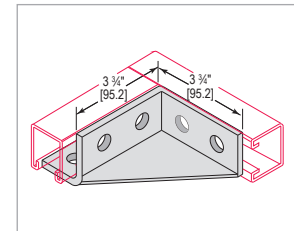

CORNER CONNECTOR 5 HOLE OPPOSED

- Standard finish is Zinc Electroplate.

Part #	Box Qty
WFO5HEG ★	15

★ Made in USA

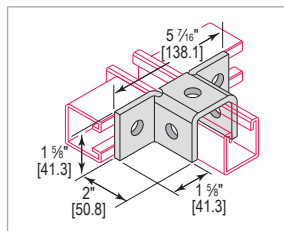

CORNER CONNECTOR 8 HOLE OPPOSED

- Standard finish is Zinc Electroplate.

Part #	Box Qty
WFO8HEG ★	25

★ Made in USA

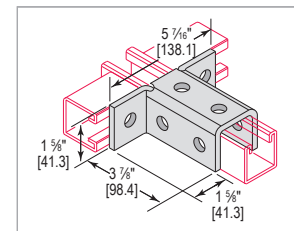

• Holes are 1/16 diameter, 13/16 center to edge on 1 7/8 centers unless specified

**CORNER CONNECTOR
10 HOLE OPPOSED**

- Standard finish is Zinc Electroplate.

Part #	Box Qty
WFO10HEG ★	25

★ Made in USA

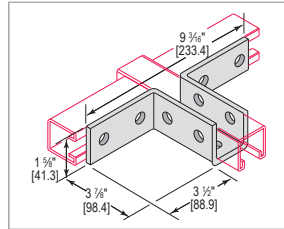

**DOUBLE CORNER
8 HOLE GUSSET**

- Standard finish is Zinc Electroplate.

Part #	Box Qty
WFDG8HEG ★	5

★ Made in USA

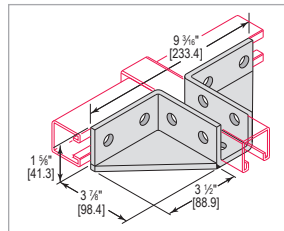

**CORNER CONNECTOR 10 HOLE
OPPOSED DOUBLE GUSSET**

- Standard finish is Zinc Electroplate.

Part #	Box Qty
WFODG10HEG ★	25

★ Made in USA

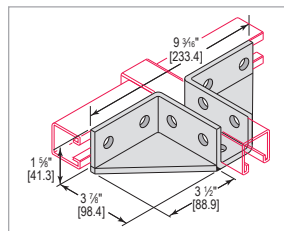

**DOUBLE CORNER
CONNECTOR 8 HOLE**

- Standard finish is Zinc Electroplate.

Part #	Box Qty
WFDC8HEG ★	25

★ Made in USA

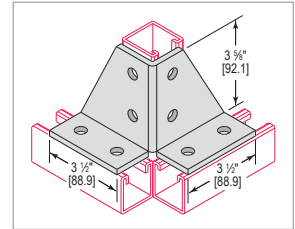

**DOUBLE CORNER 8 HOLE
DOUBLE GUSSET**

- Standard finish is Zinc Electroplate.

Part #	Box Qty
WFDDG8HEG ★	5

★ Made in USA

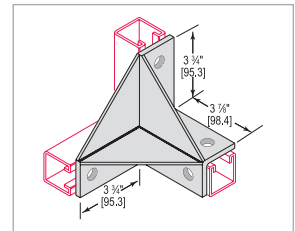

**DOUBLE CORNER
4 HOLE**

- Standard finish is Zinc Electroplate.

Part #	Box Qty
WFD4HEG ★	25

★ Made in USA

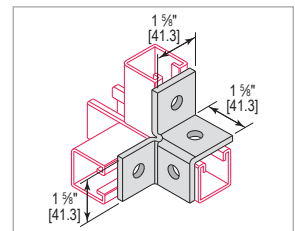

• Holes are 9/16 diameter, 13/16 center to edge on 1 1/8 centers unless specified

**DOUBLE CORNER
6 HOLE**

- Standard finish is Zinc Electroplate.

Part #	Box Qty
WFD6HEG ★	25

★ Made in USA

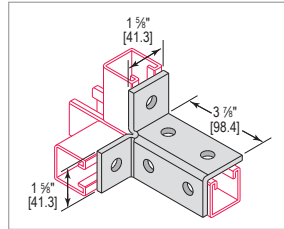

**DOUBLE CORNER
8 HOLE**

- Standard finish is Zinc Electroplate.

Part #	Box Qty
WFD8HEG ★	15

★ Made in USA

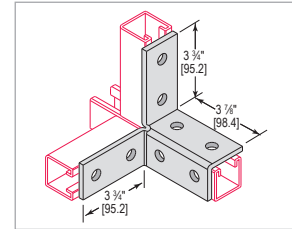

**TRIPLE CORNER
6 HOLE**

- Standard finish is Zinc Electroplate.

Part #	Box Qty
WFT6HEG ★	25

★ Made in USA

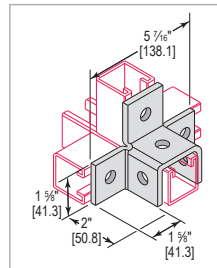

**TRIPLE CORNER
9 HOLE**

- Standard finish is Zinc Electroplate.

Part #	Box Qty
WFT9HEG ★	25

★ Made in USA

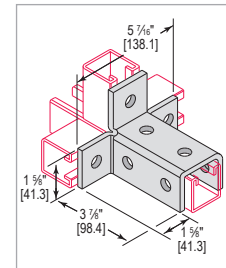

**TRIPLE CORNER
12 HOLE**

- Standard finish is Zinc Electroplate.

Part #	Box Qty
WFT12HEG ★	25

★ Made in USA

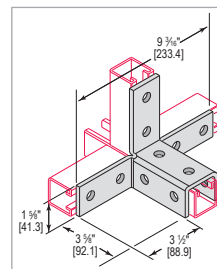

**TRIPLE CORNER
12 HOLE GUSSET**

- Standard finish is Zinc Electroplate.

Part #	Box Qty
WFTG12HEG ★	25

★ Made in USA

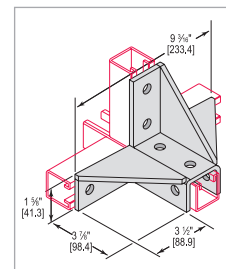

• Holes are 3/16 diameter, 13/16 center to edge on 1 7/8 centers unless specified

Z-FITTING CROSS 2 HOLE 1³/₁₆"

- Standard finish is Zinc Electroplate.

Part #	Box Qty
FZX2H81EG ★	25

★ Made in USA

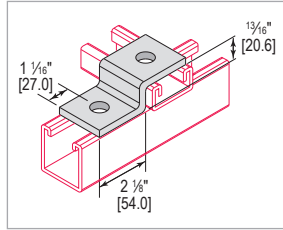

Z-FITTING CROSS 2 HOLE 1-5/8"

- Standard finish is Zinc Electroplate.

Part #	Box Qty
FZX2H162EG ★	25

★ Made in USA

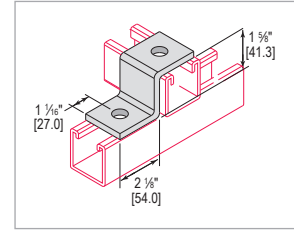

Z-FITTING CROSS 2 HOLE 2-7/16"

- Standard finish is Zinc Electroplate.

Part #	Box Qty
FZX2H243EG ★	25

★ Made in USA

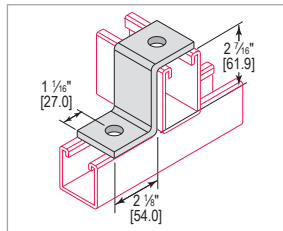

Z-FITTING CROSS 2 HOLE 3-1/4"

- Standard finish is Zinc Electroplate.

Part #	Box Qty
FZX2H325EG ★	25

★ Made in USA

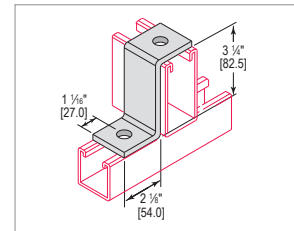

Z-FITTING CROSS 2 HOLE 1

- Standard finish is Zinc Electroplate.

Part #	Box Qty
FZX2H1EG ★	25

★ Made in USA

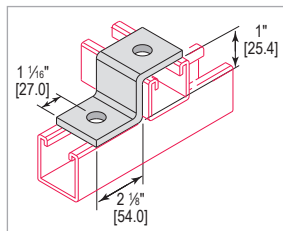

Z-FITTING OFFSET SUPPORT 2 HOLE

- Standard finish is Zinc Electroplate.

Part #	Box Qty
FZS02HEG ★	25

★ Made in USA

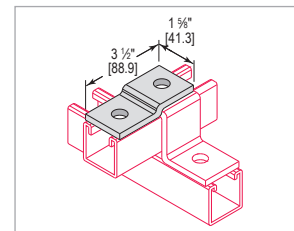

• Holes are 9/16 diameter, 13/16 center to edge on 1 7/8 centers unless specified

STRUT FITTINGS

Z-FITTING 2 HOLE SUPPORT 4"

- Standard finish is Zinc Electroplate.

Part #	Box Qty
FZS2H4EG ★	25

★ Made in USA

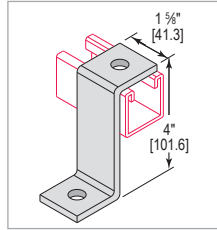

Z-FITTING 2 HOLE SUPPORT 5"

- Standard finish is Zinc Electroplate.

Part #	Box Qty
FZS2H5EG ★	25

★ Made in USA

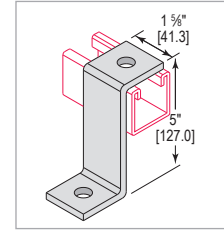

Z-FITTING 2 HOLE SUPPORT 6"

- Standard finish is Zinc Electroplate.

Part #	Box Qty
FZS2H6EG ★	25

★ Made in USA

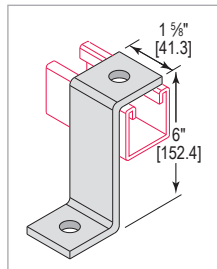

Z-FITTING 2 HOLE SUPPORT 7"

- Standard finish is Zinc Electroplate.

Part #	Box Qty
FZS2H7EG ★	25

★ Made in USA

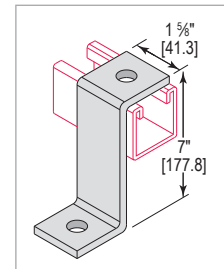

Z-FITTING 2 HOLE SUPPORT 8"

- Standard finish is Zinc Electroplate.

Part #	Box Qty
FZS2H8EG ★	25

★ Made in USA

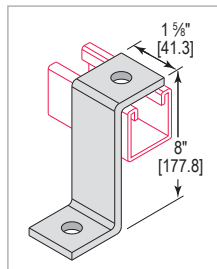

Z-FITTING SLOTTED SUPPORT

- Standard finish is Zinc Electroplate.

Part #	Box Qty
FZSSEG ★	10

★ Made in USA

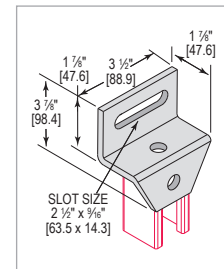

• Holes are 5/16 diameter, 13/16 center to edge on 1 7/8 centers unless specified

Z-FITTING CHANNEL HANGER 1-5/8"

- Standard finish is Zinc Electroplate.

Part #	Box Qty
FZCH162EG ★	100

★ Made in USA

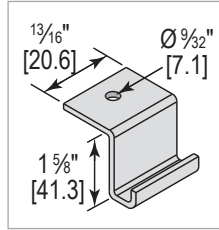

Z-FITTING CHANNEL HANGER 2-7/16"

- Standard finish is Zinc Electroplate.

Part #	Box Qty
FZCH243EG ★	100

★ Made in USA

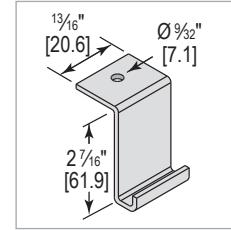

Z-FITTING CHANNEL HANGER 3-1/4"

- Standard finish is Zinc Electroplate.

Part #	Box Qty
FZCH325EG ★	100

★ Made in USA

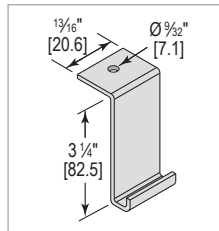

Z-FITTING CORNER BRACE 3 HOLE

- Standard finish is Zinc Electroplate.

Part #	Box Qty
FFZB3HEG ★	25

★ Made in USA

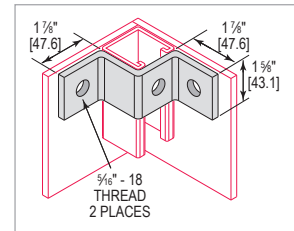

Z-FITTING CORNER BRACE 8 HOLE

- Standard finish is Zinc Electroplate.

Part #	Box Qty
FZB8HEG ★	5

★ Made in USA

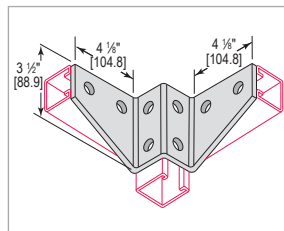

- Holes are 9/16 diameter, 13/16 center to edge on 1 7/8 centers unless specified

STRUT FITTINGS

Black Claw™

By **Minerallac** Company

Strong, Swift, and Efficient

Our Black Claw™ line of premium fasteners is constructed from high-carbon steel that has been engineered and manufactured to ensure a tight, secure “claw grip” on flanges, conduit, cable, studs and T-bars. Winning rave reviews by contractors, these products are hailed for their strength and efficient installation.

314-322 Conduit Cable

323-326 Hangers

327-332 Beam/Purlin

333-337 Metal Stud

338-341 Acoustical

342 Hardware/Accessories

**343-344 Compatibility & Size
Reference Charts**



CONDUIT CLIP



HIC75

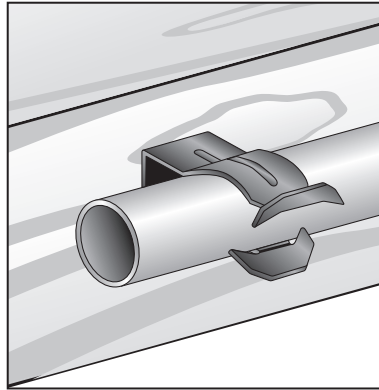

Ultimate Static Load Limit:
25lbs Vertical Position
15lbs Horizontal Position

- No fastener required.

Fits EMT	Fits Rigid/IMC	Part #	Std Pkg
1/2	—	HIC50 ★	100
3/4	1/2	HIC75 ★	100
1	3/4	HIC100 ★	100

★ Made in USA

Ultimate Static Load Limit



KC38

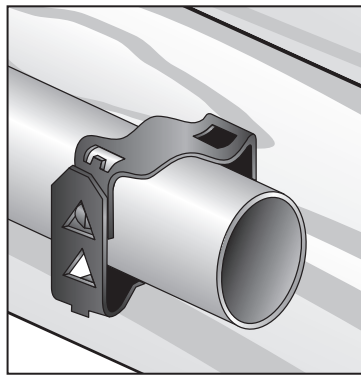

Static Load Limit:
100lbs Vertical Position
25lbs Horizontal Position

- No fastener required.
- 1/2" and 3/4" available both non-keyholed and keyholed for 1/4"-20 screw.

Fits Conduit	Part #	Std Pkg
3/8	KC38 ★	100
1/2, 3/4	KC1234 ★	100
1	KC1 ★	100
1 1/4	KC114 ★	100
1 1/2	KC112 ★	100
2	KC2 ★	100

Static Load Limit

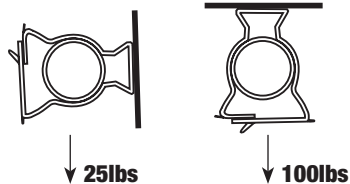

With Thread Impression for 1/4"-20	Part #	Std Pkg
1/2, 3/4	KC1234T ★	100

★ Made in USA

CONDUIT TO CONDUIT TRAPEZE ASSEMBLY

- No fastener required.
- Designed to quickly secure one conduit run to another.

NOTE: Top conduit to be used for support only, not a raceway.

Connects Conduit		Part #	Std Pkg
EMT	Rigid/IMC		
1/2 to 1/2	—	HIC5050 ★	100
1/2 to 3/4	—	HIC5075 ★	100
3/4 to 3/4	1/2 to 1/2	HIC7575 ★	100

★ Made in USA

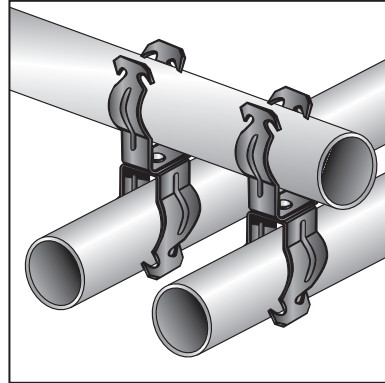

HIC7575

- Total load of trapeze must not exceed 100lbs.
- No fastener required.
- Designed to quickly secure one conduit run to another.

Connects Conduit	Part #	Std Pkg
3/8 to 1	KC38KC1 ★	100
3/8 to 1/2 or 3/4	KC38KC1234 ★	100
1/2 or 3/4 to 1/2 or 3/4	KC1234KC1234 ★	100

★ Made in USA

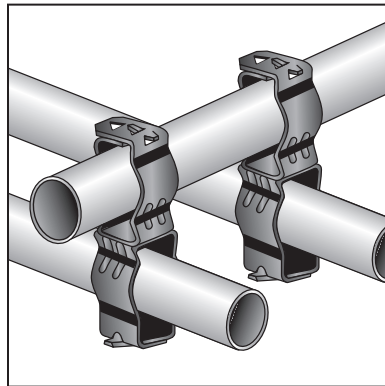

KC1234KC1234

BLACK CLAW

FLEX CONDUIT & WIRE SUPPORT

Connects Conduit	Part #	Std Pkg
	FCWS6	100



CABLE CLIP

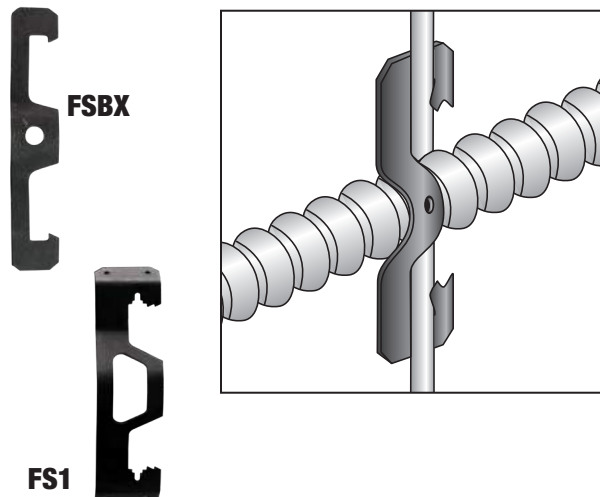

- Clip for MC, AC, or BX. Supports cable from #12 to #8 wire in horizontal or vertical position. O.D.'s from .433 to .535.

NOTE: These products are designed for positioning only. No load rating.

Cable Size	#12 Wire	#10 Wire	#8 & #9 Wire	Std Pkg
14-2 Cable	FSBX ★	FSBX ★	FSBX ★	100
14-3 Cable	FSBX ★	FSBX ★	FSBX ★	100
12-2 Cable	FSBX ★	FSBX ★	FSBX ★	100
12-3 Cable	FSBX ★	FS1 ★	FS1 ★	100

★ Made in USA

CONDUIT CLIP

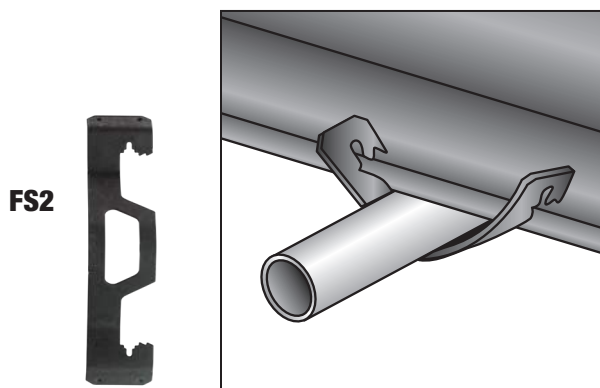

- Supports conduit and all types of cable from rods or flanges.

Conduit Size	#10 & #12 Wire	#8 & #9 Wire	3/16" to 1/4" Rod	Std Pkg
1/2" EMT	FS1 ★	FS1 ★	FS1 ★	100
1/2" RIGID	FS1 ★	FS2 ★	FS2 ★	100
3/4" EMT	FS2 ★	FS2 ★	FS2 ★	100
3/4" RIGID	FS2 ★	FS2 ★	FS3 ★	100
1" EMT	—	FS3 ★	FS3 ★	100
1" RIGID	—	—	—	100
1 1/4" EMT	—	FS4 ★	FS4 ★	100

Static Load Limit

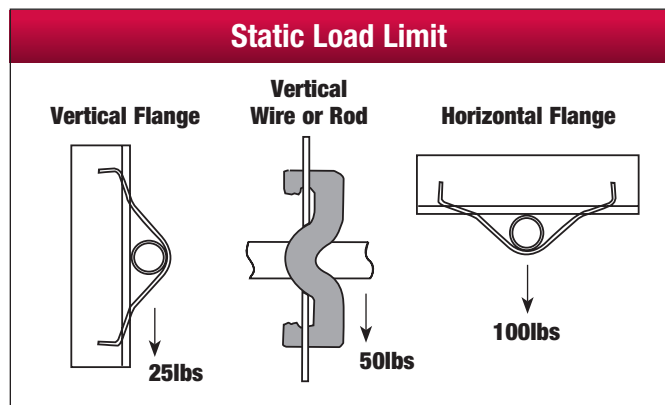

Conduit Size	1/8" to 1/4" Flange	5/16" to 3/8" Flange	7/16" to 1/2" Flange	Std Pkg
1/2" EMT	FS1 ★	FS2 ★	FS2 ★	100
1/2" RIGID	FS2 ★	FS2 ★	FS3 ★	100
3/4" EMT	FS2 ★	FS3 ★	FS3 ★	100
3/4" RIGID	FS3 ★	FS4* ★	FS4* ★	100
1" EMT	FS3 ★	FS4* ★	FS4* ★	100
1" RIGID	FS4* ★	FS4* ★	FS4* ★	100
1 1/4" EMT	FS4 ★	—	—	100

*For horizontal applications only.

★ Made in USA

MULTI-FUNCTION CLIP

- Attaches conduit or boxes to flanges, wire or rod.
- Attaches to #12 wire through 3/8" rod.
- Attaches #10-24 or 1/4"-20 threaded bridle rings (position only).

Description	Part #	Std Pkg
Fits 1/8" to 3/8" Flanges; #12 Wire through 3/8" Rod; #10-24 or 1/4"-20 Threaded Impressions	APS ★	100

★ Made in USA

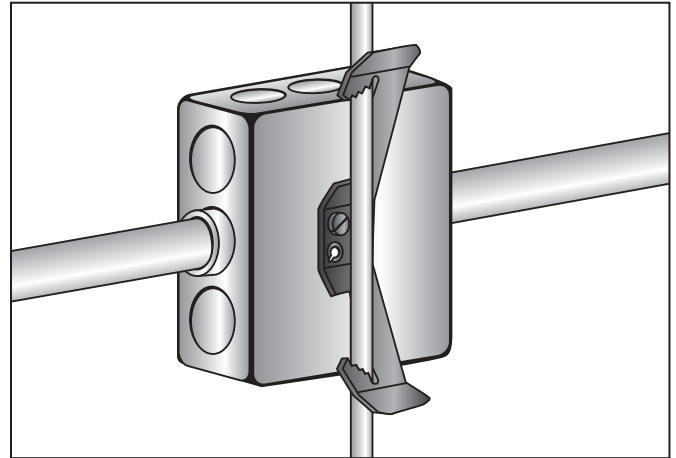

Static Load Limit (Flange)

50lbs 20lbs



MULTI-FUNCTION CLIP ASSEMBLIES

- Attaches conduit or boxes to flanges, wire or rod.

Fits		Part #	Std Pkg
EMT	Rigid/IMC		
1/2	—	APS50 ★	100
3/4	1/2	APS75 ★	100
1	3/4	APS100 ★	100

Fits Conduit	Part #	Std Pkg
1/2 & 3/4	APSKC1234 ★	100
1	APSKC1 ★	100

★ Made in USA

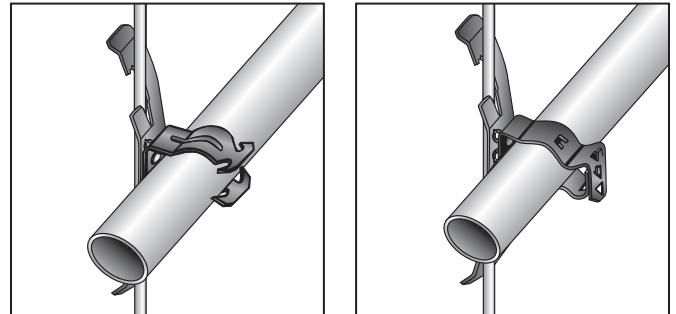

Ultimate Static Load Limit (Flange)

25lbs 15lbs



Static Load Limit (Flange)

50lbs 20lbs



BLACK CLAW

FLEXIBLE CONDUIT/CABLE CLIP

- Supports flexible conduit and all types of cable from flanges.
- Made from high-carbon steel and zinc plated.
- Some clips may require minimum order quantities. Please contact customer service.

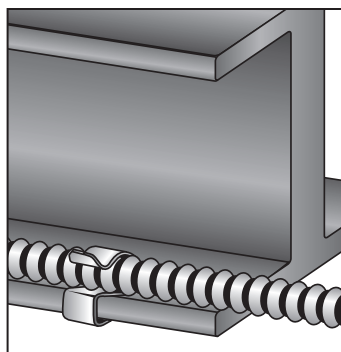

F2A

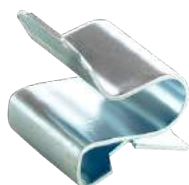

Description		Part #	Std Pkg
AC/MC Cable O.D.	Flange Size		
.218-.281	1/16-3/16	F2A ★	100
.312-.375	1/16-3/16	F2B ★	100
.375-.437	1/16-3/16	F2C ★	100
.468-.562	1/16-3/16	F2D ★	100
0.500-0.718	1/16-3/16	F2E ★	100
.750-.937	1/16-3/16	F2F ★	100
.968-1.250	1/16-3/16	F2G ★	100
.218-.281	3/16-9/32	F4A ★	100
.312-.375	3/16-9/32	F4B ★	100
.375-.437	3/16-9/32	F4C ★	100
.468-.562	3/16-9/32	F4D ★	100
0.500-0.718	3/16-9/32	F4E ★	100
.750-.937	3/16-9/32	F4F ★	100
.968-1.250	3/16-9/32	F4G ★	100
.218-.281	5/16-1/2	F8A ★	100
.312-.375	5/16-1/2	F8B ★	100
.375-.437	5/16-1/2	F8C ★	100
.468-.562	5/16-1/2	F8D ★	100
0.500-0.718	5/16-1/2	F8E ★	100
.750-.937	5/16-1/2	F8F ★	100
.968-1.250	5/16-1/2	F8G ★	100

★ Made in USA

FLANGE MOUNT CONDUIT CLIP ASSEMBLY

Ultimate Static Load Limit: 25lbs

- Suspends conduit from bottom of beam.
- Will pivot 360 degrees.
- Installs with hammer only.

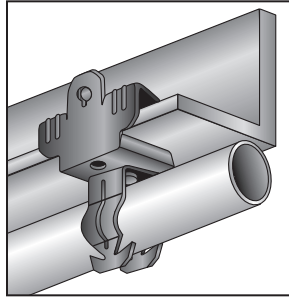

Static Load Limit: 75lbs

- Suspends conduit from bottom of beam.
- Will pivot 360 degrees.
- Installs with hammer only.

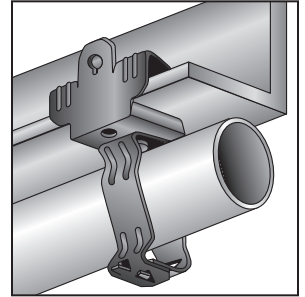

Ultimate Static Load Limit

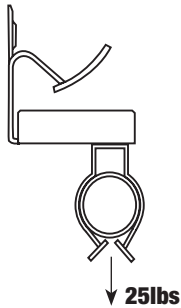

Bottom Mount



BC1875

Static Load Limit



Bottom Mount



BC18KC38

Fits Flange	Fits EMT	Fits Rigid/IMC	Part #	Std Pkg
1/8-1/4	1/2	—	BC1850 ★	100
1/8-1/4	3/4	1/2	BC1875 ★	100
1/8-1/4	1	3/4	BC18100 ★	100
5/16-1/2	1/2	—	BC51650 ★	100
5/16-1/2	3/4	1/2	BC51675 ★	100
5/16-1/2	1	3/4	BC516100 ★	100

★ Made in USA

Fits Flange	Fits Conduit	Part #	Std Pkg
1/8-1/4	3/8	BC18KC38 ★	100
1/8-1/4	1/2 & 3/4	BC18KC1234 ★	100
1/8-1/4	1	BC18KC1 ★	100
1/8-1/4	1 1/4	BC18KC114 ★	100
1/8-1/4	1 1/2	BC18KC112 ★	100
1/8-1/4	2	BC18KC2 ★	100
5/16-1/2	3/8	BC516KC38 ★	100
5/16-1/2	1/2 & 3/4	BC516KC1234 ★	100
5/16-1/2	1	BC516KC1 ★	100
5/16-1/2	1 1/4	BC516KC114 ★	100
5/16-1/2	1 1/2	BC516KC112 ★	100
5/16-1/2	2	BC516KC2 ★	100
9/16-3/4	3/8	BC916KC38 ★	100
9/16-3/4	1/2 & 3/4	BC916KC1234 ★	100
9/16-3/4	1	BC916KC1 ★	100
9/16-3/4	1 1/4	BC916KC114 ★	100
9/16-3/4	1 1/2	BC916KC112 ★	100
9/16-3/4	2	BC916KC2 ★	100

★ Made in USA

FLANGE MOUNT CONDUIT CLIP ASSEMBLY

Ultimate Static Load Limit: 15lbs

- Suspends conduit from side of beam.
- Will pivot 360 degrees.
- Installs with hammer only.

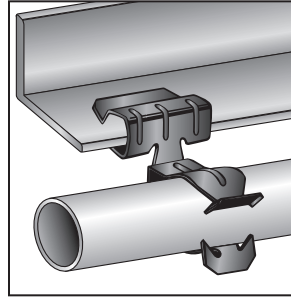

Static Load Limit: 25lbs

- Suspends conduit from side of beam.
- Will pivot 360 degrees.
- Installs with hammer only.

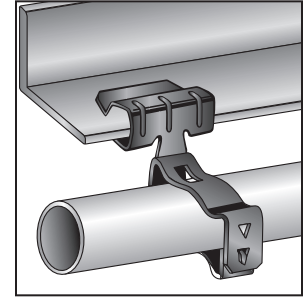

Ultimate Static Load Limit

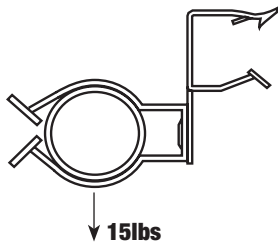

Side Mount



SFC1875

Static Load Limit

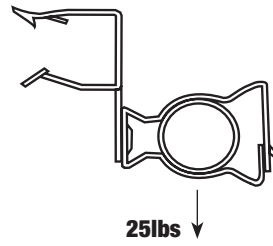

Side Mount



SFC516KC1

Fits Flange	Fits EMT	Fits Rigid/IMC	Part #	Std Pkg
1/8-1/4	1/2	—	SFC1850 ★	100
1/8-1/4	3/4	1/2	SFC1875 ★	100
1/8-1/4	1	3/4	SFC18100 ★	100

★ Made in USA

Fits Flange	Fits Conduit	Part #	Std Pkg
1/8-1/4	3/8	SFC18KC38 ★	100
1/8-1/4	1/2 & 3/4	SFC18KC1234 ★	100
1/8-1/4	1	SFC18KC1 ★	100
1/8-1/4	1 1/4	SFC18KC114 ★	100
1/8-1/4	1 1/2	SFC18KC112 ★	100
1/8-1/4	2	SFC18KC2 ★	100
5/16-1/2	3/8	SFC516KC38 ★	100
5/16-1/2	1/2 & 3/4	SFC516KC1234 ★	100
5/16-1/2	1	SFC516KC1 ★	100
5/16-1/2	1 1/4	SFC516KC114 ★	100
5/16-1/2	1 1/2	SFC516KC112 ★	100
5/16-1/2	2	SFC516KC2 ★	100
9/16-3/4	3/8	SFC916KC38 ★	100
9/16-3/4	1/2 & 3/4	SFC916KC1234 ★	100
9/16-3/4	1	SFC916KC1 ★	100

★ Made in USA

CONDUIT & BOX SUPPORT FASTENERS

- Secures conduit and electrical boxes to most structures.
- Provides conduit support on both sides of electrical box.
- With hole for screw or threaded rod mount or with 1/4"-20 x 5/8" stud.
- Made from pre-galvanized steel with Black Claw™ spring steel fasteners riveted to part.
- This part with beam clamp attachment found on page 332.

Mount 4" Square Boxes For Use With	Part #	Std Pkg
3/8" Conduit	CBS18KC38 ★	25
1/2", 3/4" Conduit	CBS18KC1234 ★	25
1" Conduit	CBS18KC1 ★	25

★ Made in USA

Stud Mount 4" Square Boxes For Use With	Part #	Std Pkg
3/8" Conduit	CBS18KC38ST	25
1/2", 3/4" Conduit	CBS18KC1234ST	25
1" Conduit	CBS18KC1ST	25

- Secures conduit and electrical boxes to most structures.
- Provides conduit support on both sides of electrical box.
- With hole for screw or threaded rod mount or with 1/4"-20 x 5/8" stud.
- Made from pre-galvanized steel with Black Claw™ spring steel fasteners riveted to part.
- This part with beam clamp attachment found on page 332.

Mount 4" Square Boxes For Use With	Part #	Std Pkg
1/2" EMT	CBS18HIC50 ★	25
3/4" EMT or 1/2" Rigid	CBS18HIC75 ★	25
1" EMT or 3/4" Rigid	CBS18HIC100 ★	25

★ Made in USA

Stud Mount 4" Square Boxes For Use With	Part #	Std Pkg
1/2" EMT	CBS18HIC50ST	25
3/4" EMT or 1/2" Rigid	CBS18HIC75ST	25
1" EMT or 3/4" Rigid	CBS18HIC100ST	25

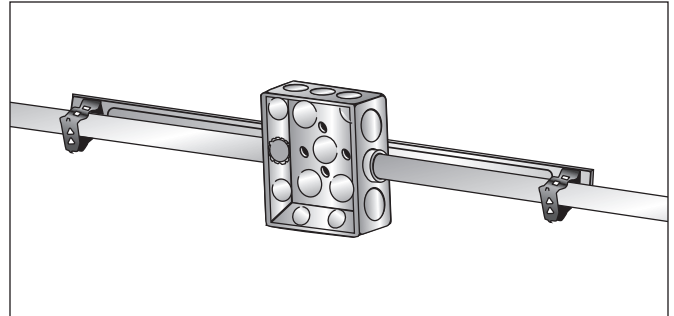

CBS18KC1234



CBS18KC1234ST

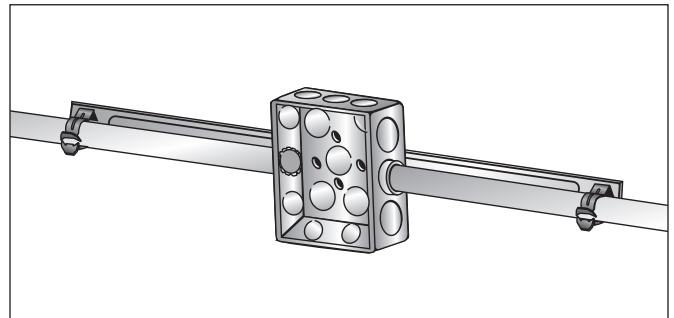

CBS18HIC100



CBS18HIC100ST



CONDUIT & BOX SUPPORT ASSEMBLY

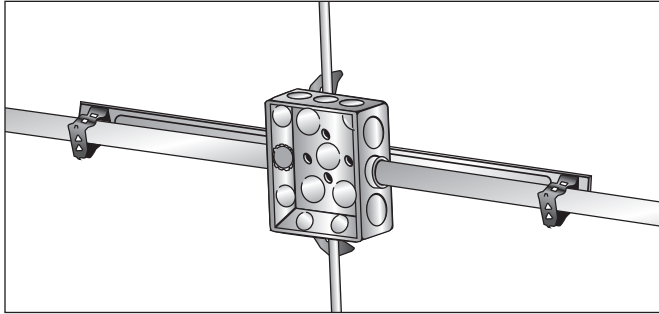

CBS18KC1234APS

- Provides conduit support on both sides of electrical box.
- Attaches to #12 wire thru 3/8" rod.
- Made from pre-galvanized steel with Black Claw™ spring steel fasteners riveted to part.
- This part with beam clamp attachment, instead of multi-function clip shown below, found on page 332.

Mount 4" Square Boxes For Use With	Part #	Std Pkg
3/8" Conduit	CBS18KC38APS ★	25
1/2", 3/4" Conduit	CBS18KC1234APS ★	25
1" Conduit	CBS18KC1APS ★	25

★ Made in USA

BLACK CLAW

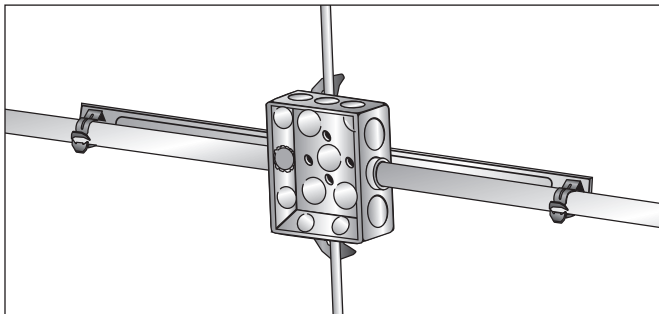

CBS18HIC100APS

- Provides conduit support on both sides of electrical box.
- Attaches to #12 wire thru 3/8" rod.
- Made from pre-galvanized steel with Black Claw™ spring steel fasteners riveted to part.
- This part with beam clamp attachment, instead of multi-function clip shown below, found on page 332.

Mount 4" Square Boxes For Use With	Part #	Std Pkg
1/2" EMT	CBS18HIC50APS ★	25
3/4" EMT or 1/2" Rigid	CBS18HIC75APS ★	25
1" EMT or 3/4" Rigid	CBS18HIC100APS ★	25

★ Made in USA

ROD/WIRE • BRACKET SUPPORT

Angle Brackets

Static Load Limit: 160lbs

- Suspends #8 wire, 1/4" and 3/8" plain or threaded rod from overhead mountings with a clearance hole for 1/4" bolt.
- Hangers made from high-carbon steel, zinc phosphate and oil finish. Angle bracket made from pre-galvanized steel.

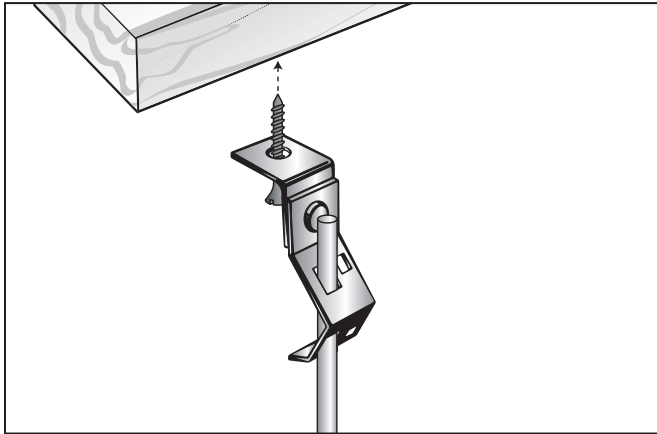

Offset Brackets

Static Load Limit: 160lbs

- Suspends #8 wire, 1/4" and 3/8" plain or threaded rod from overhead mountings with a clearance hole for 1/4" bolt.
- Hangers made from high-carbon steel, zinc phosphate and oil finish. Offset bracket made from pre-galvanized steel.

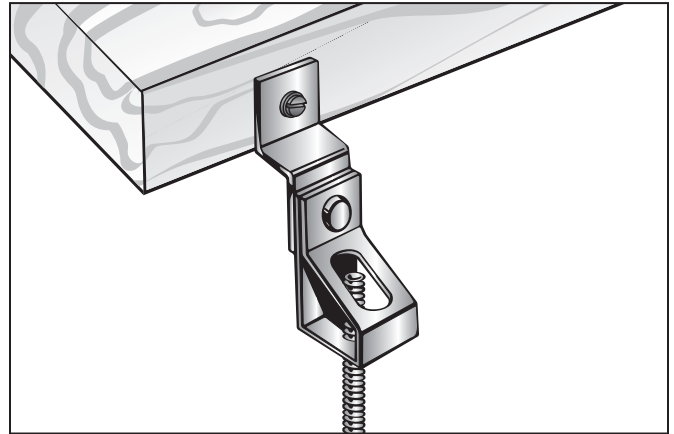

BLACK CLAW

Angle Bracket Supports For Use With	Part #	Std Pkg
#8 Wire or 1/4" Plain Rod	RA14 ★	100
3/8" Plain Rod	RA38 ★	100
1/4" Threaded Rod with Thread Impression	RA14T ★	100
3/8" Threaded Rod with Thread Impression	RA38T ★	100
1/4" to 3/8" Threaded Rod*	RA1438N ★	100

*Nut required

★ Made in USA

Angle Bracket Supports For Use With	Part #	Std Pkg
#8 Wire or 1/4" Plain Rod	R014 ★	100
3/8" Plain Rod	R038 ★	100
1/4" Threaded Rod with Thread Impression	R014T ★	100
3/8" Threaded Rod with Thread Impression	R038T ★	100
1/4" to 3/8" Threaded Rod*	R01438N ★	100

*Nut required

★ Made in USA

ROD/WIRE BEAM ASSEMBLIES

Static Load Limit: 160lbs

- Suspends #8 wire, 1/4" and 3/8" plain rod from overhead mountings.

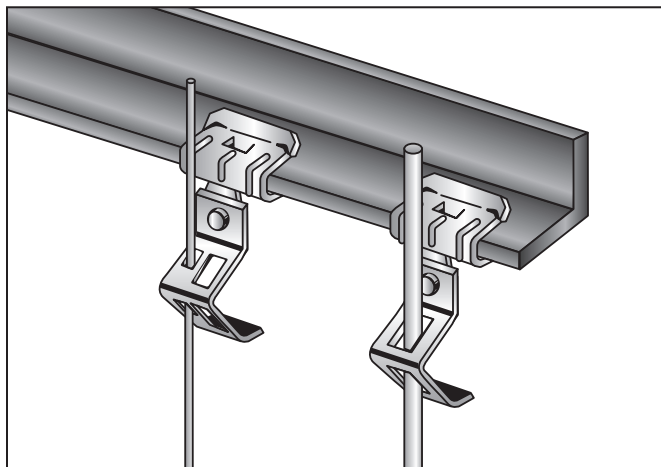

R1814

THREADED ROD TO BEAM ASSEMBLIES

Static Load Limit: 160lbs

- Suspends 1/4" and 3/8" threaded rod from overhead mountings.

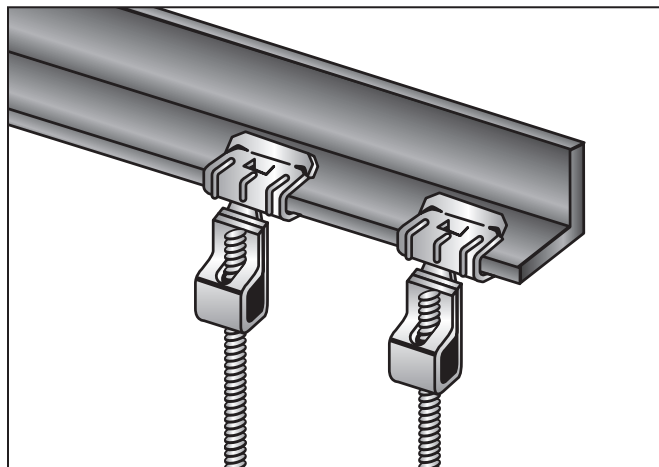

R1814T

BLACK CLAW

Flange Thickness	For Use With	Part #	Std Pkg
1/8-1/4	#8 Wire or 1/4" Plain Rod	R1814 ★	100
5/16-1/2	#8 Wire or 1/4" Plain Rod	R51614 ★	100
9/16-3/4	#8 Wire or 1/4" Plain Rod	R91614 ★	100
1/8-1/4	3/8" Plain Rod	R1838 ★	100
5/16-1/2	3/8" Plain Rod	R51638 ★	100
9/16-3/4	3/8" Plain Rod	R91638 ★	100

★ Made in USA

Flange Thickness	For Use With (Thread Impression)	Part #	Std Pkg
1/8-1/4	1/4" Threaded Rod	R1814T ★	100
5/16-1/2	1/4" Threaded Rod	R51614T ★	100
9/16-3/4	1/4" Threaded Rod	R91614T ★	100
1/8-1/4	3/8" Threaded Rod	R1838T ★	100
5/16-1/2	3/8" Threaded Rod	R51638T ★	100
9/16-3/4	3/8" Threaded Rod	R91638T ★	100

★ Made in USA

STRAP HANGERS

Static Load Limit: 200lbs

- Suspends strapping thru 1" wide from beam flanges 1/8" to 3/4" thick, parallel or at right angles to beam.

Flange Thickness	Part #	Std Pkg
1/8-1/4	PSF18 ★	100
5/16-1/2	PSF516 ★	100
9/16-3/4	PSF916 ★	100

Right Angle Strap Fits Flange Thickness	Part #	Std Pkg
1/8-1/4	PSF18R ★	100
5/16-1/2	PSF516R ★	100
9/16-3/4	PSF916R ★	100

★ Made in USA

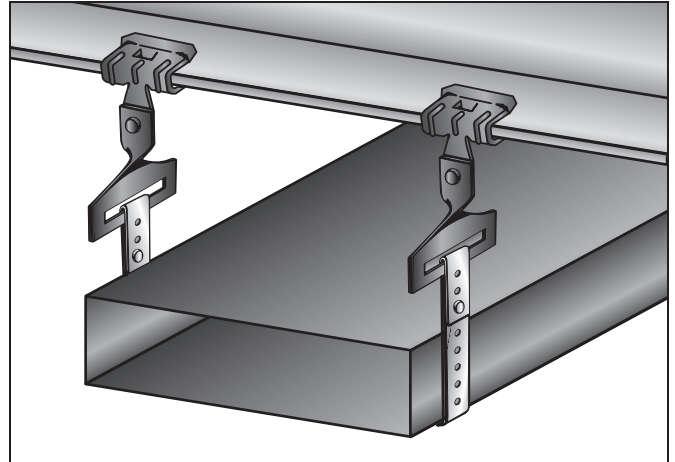

BLACK CLAW

ROD HANGERS

Static Load Capacity: 160lbs

- Used for hanging rod.

For Use With	Part #	Std Pkg
1/4" or 3/8" Threaded Rod*	R1438N ★	100
1/4" Threaded Rod with Threaded Impression	R14T ★	100
3/8" Threaded Rod with Threaded Impression	R38T ★	100

*Nut required

★ Made in USA



R38T

BEAM CLAMPS

Static Load Limit: 75lbs or 100lbs

- Can be used to suspend boxes, fixtures and bridle rings to beam flanges 1/8" to 3/4" thick.
- Beam Clamp with 1/4"-20 x 3/8" staked stud used to suspend box from bottom of beam.

NOTE: Static load limits cannot be combined.

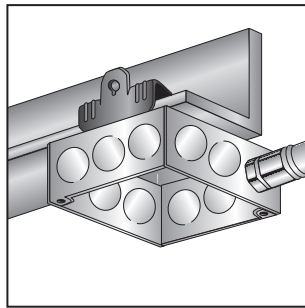
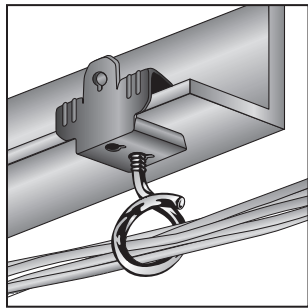

Static Load Limit: 100lbs

- Fast installation; fits beam flange to 1/2".
- Used with 1/4" and 3/8" threaded rod, "S" hooks, conduit hangers, electrical boxes, and #10-24 or 1/4"-20 bridle rings.
- Tapping 1/4"-20 bottom and back. Also #10-24 tapping on back.

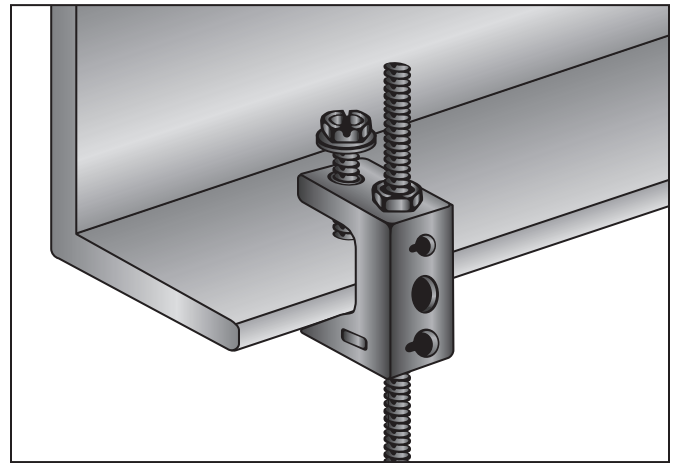

Static Load Limit

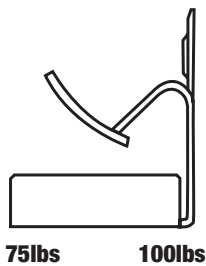

75lbs

100lbs

BC18



BC916ST



500



Flange Thickness	Part #	Std Pkg
Bottom & Back Tapped 1/4"-20		
1/8-1/4	BC18 ★	100
5/16-1/2	BC516 ★	100
9/16-3/4	BC916 ★	100
1/4"-20 x 3/8" Stud		
1/8-1/4	BC18ST	100
5/16-1/2	BC516ST	100
9/16-3/4	BC916ST	100

Accommodates		Part #	Std Pkg
Flange	Drop Rod		
Up to 1/2" Thick	1/4-3/8"	500	100

★ Made in USA

BEAM CLAMP TO CONDUIT HANGER ASSEMBLIES

Ultimate Static Load Limit:

25lbs Vertical Position
15lbs Horizontal Position

- Our #500 beam clamp with conduit hanger attached.

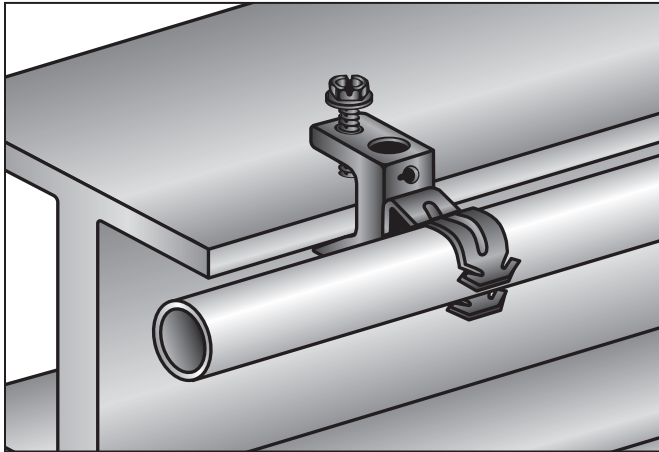

Static Load Limit:

100lbs Vertical Position
25lbs Horizontal Position

- Part #500 beam clamp with conduit hanger attached.

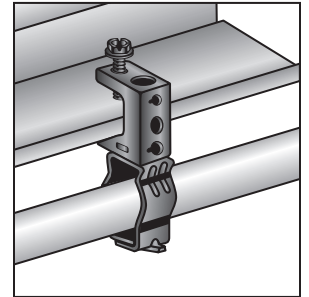

500KC1234



50050



50050B



500KC1234B

Fits EMT	Fits Rigid/IMC	Part #	Std Pkg
1/2	—	50050	100
3/4	1/2	50075	100
1	3/4	500100	100
1/2	—	50050B	100
3/4	1/2	50075B	100
1	3/4	500100B	100

Fits Conduit	Part #	Std Pkg
1/2 & 3/4	500KC1234	100
1	500KC1	100
1 1/4	500KC114	100
1 1/2	500KC112	100
2	500KC2	100
1/2 & 3/4	500KC1234B	100
1	500KC1B	100

FLANGE BEAM CLAMP

Static Load Limit: 200lbs

- Installed with hammer on bulb tees and beams.
- Clearance for 1/4" bolt in tab.



SFC516

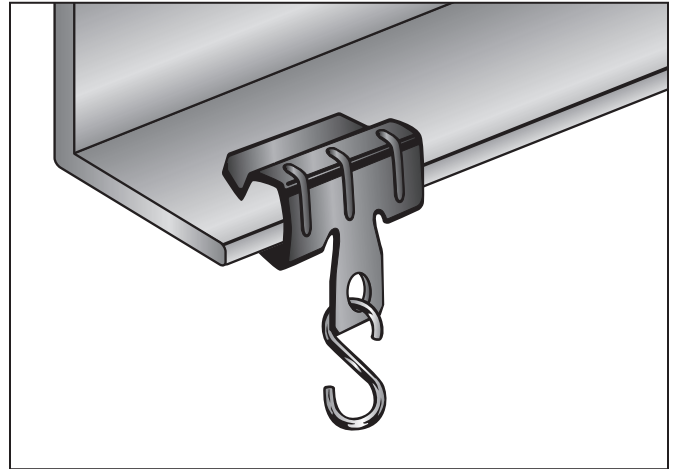

Flange Thickness	Part #	Std Pkg
1/8-1/4	SFC18 ★	100
5/16-1/2	SFC516 ★	100
9/16-3/4	SFC916 ★	100

★ Made in USA

Z PURLIN HANGER

Static Load Limit: 100lbs

- Installed without power tools.
- Compensates for angle of purlin.

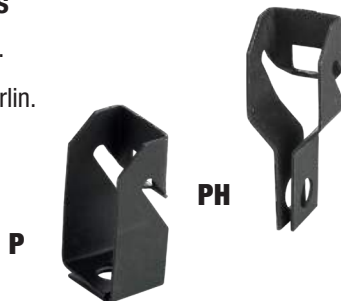

P

PH

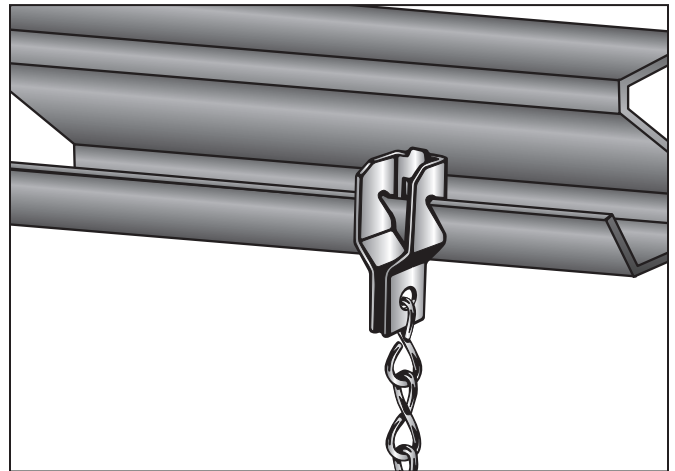

Description	Part #	Std Pkg
1/4" Bottom Hole	P ★	100
1/4" Hole for Wire, S-Hooks, Perforated Strap and Jack Chain	PH ★	100

★ Made in USA

Z PURLIN HANGER ASSEMBLIES

Static Load Limit: 100lbs

- Installed without power tools.
- Compensates for angle of purlin.

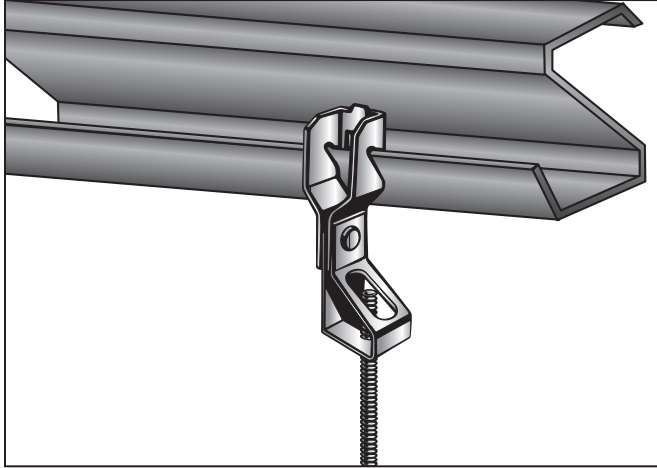

PH14T

For Use With	Part #	Std Pkg
1/4" Threaded Rod	PH14T ★	100
3/8" Threaded Rod	PH38T ★	100
Up to 19 Strap	PHPSR ★	100

★ Made in USA

Ultimate Static Load Limit: 25lbs

- Installed without power tools.
- Compensates for angle of purlin.

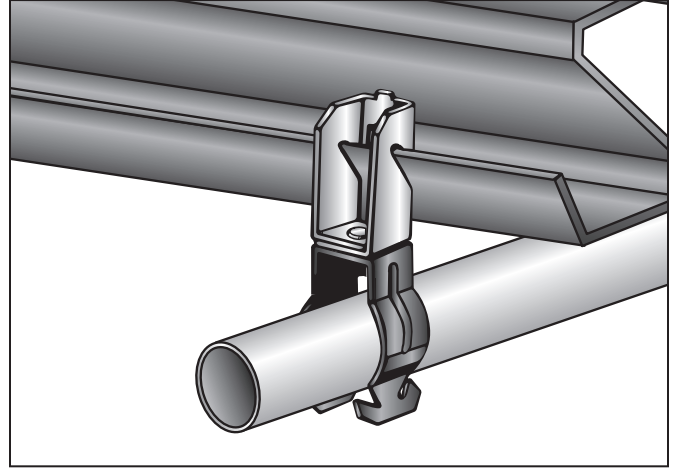

P50

Description	Part #	Std Pkg
1/2" EMT	P50 ★	100
1/2" EMT or 3/4" Rigid	P75 ★	100
1" EMT or 3/4" Rigid	P100 ★	50

★ Made in USA

Z PURLIN ROD ASSEMBLIES

- Fits 1/8" to 1/4" Z Purlin.

Size	Part #	Std Pkg
1/4"-20	ABC25R14T ★	100
1/4" or 3/8"	ABC25R1438N ★	100
3/8"-16	ABC25R38T ★	100



ABC25R38T

VERT FLANGE ROD ASSEMBLIES

Size	Part #	Std Pkg
1/4"-20	VBC25R14T ★	100
1/4" or 3/8"	VBC25R1438N★	100
3/8"-16	VBC25R38T ★	100

★ Made in USA

Static Load Limit: 100lbs

- Fits 1/16" to 1/4" flange.

VBC25R1438N



Z PURLIN HANGER ASSEMBLIES

Description	Part #	Std Pkg
3/8" Conduit to Z Purlin	PKC38 ★	100
1/2" or 3/8" Conduit to Z Purlin	PKC1234 ★	100
1" Conduit to Z Purlin	PKC1 ★	100
1 1/4" Conduit to Z Purlin	PKC114 ★	50

★ Made in USA

Static Load Limit: 100lbs

- Installed without power tools.
- Compensates for angle of purlin.



PKC38

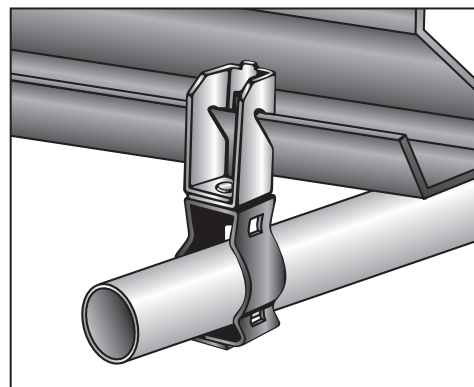

Z PURLIN FLANGE HANGER

Flange Thickness	For Use With	Part #	Std Pkg
1/16-1/4	Angled Z Purlin for S-Hooks, Perforated Strap and Wire	ABC25 ★	100
1/16-1/4	Vertical Flange for S-Hooks, Perforated Strap and Wire	VBC25 ★	100

★ Made in USA



Static Load Limit: 100lbs
ABC25



Static Load Limit: 160lbs
VBC25

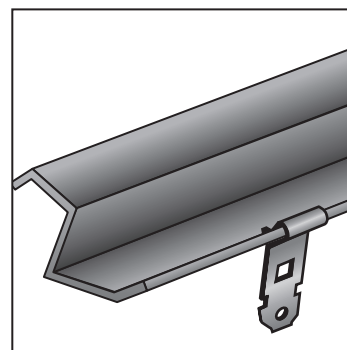

- Fits 1/16" to 1/4" thick Z Purlin (ABC25) or vertical flanges (VBC25).
- Clearance for 1/4" bolt.
- Accommodates tooling for floor installations.
- Assemblies available for ABC25 and VBC25. Please contact customer service.

FLANGE HANGER

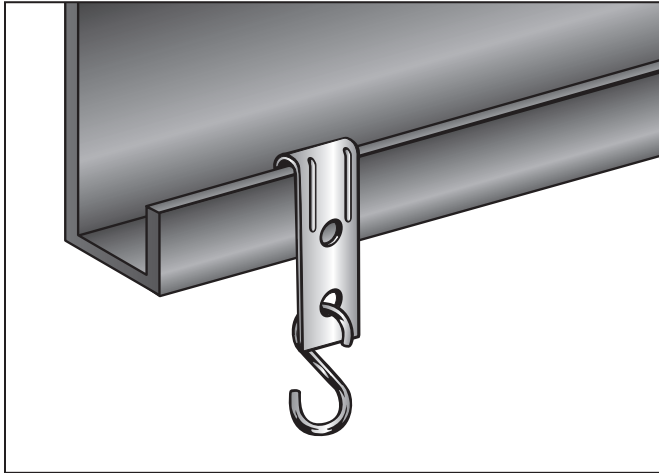

Static Load Limit: 160lbs

- Clearance for 1/4" bolt.



FH116

Flange Thickness	For Use With	Part #	Std Pkg
1/16–5/16	S-Hooks, Perforated Strap and Wire	FH116 ★	100
5/32–1/4	S-Hooks, Perforated Strap and Wire	FH532 ★	100

★ Made in USA

ROD TO FLANGE HANGER

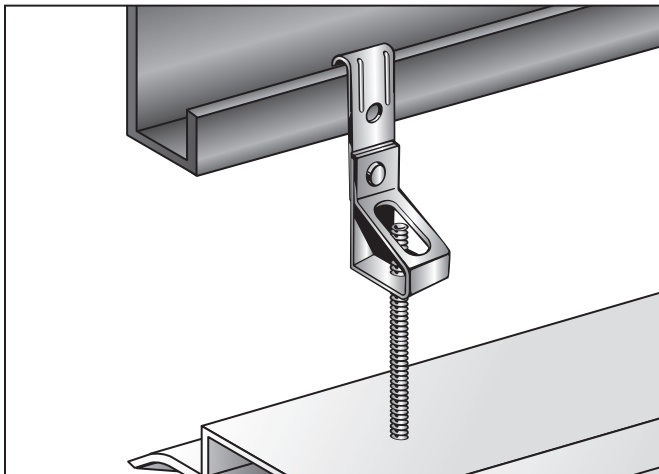

Static Load Capacity: 160lbs

- Suspends 1/4" or 3/8" threaded rod from vertical flange 1/16" to 1/4" thick.



RF11638T

Flange Thickness	For Use With	Part #	Std Pkg
1/16–5/32	1/4" Threaded Rod	RF11614T ★	100
5/32–1/4	1/4" Threaded Rod	RF53214T ★	100
1/16–5/32	3/8" Threaded Rod	RF11638T ★	100
5/32–1/4	3/8" Threaded Rod	RF53238T ★	100

★ Made in USA

BEAM MOUNT CONDUIT & BOX SUPPORT ASSEMBLY

- Provides conduit support on both sides of electrical box.
- Attaches to beam flanges from 1/8" to 1/2" thick.
- Made from pre-galvanized steel with Black Claw™ spring steel fasteners riveted to part.

Mount 4" Square Boxes		Part #	Std Pkg
Conduit Size	Flange Thickness		
3/8"	1/8-1/4	CBS18KC3818 ★	25
3/8"	5/16-1/2	CBS18KC38516 ★	25
1/2"-3/4"	1/8-1/4	CBS18KC123418 ★	25
1/2"-3/4"	5/16-1/2	CBS18KC1234516 ★	25
1"	1/8-1/4	CBS18KC118 ★	25
1"	5/16-1/2	CBS18KC1516 ★	25

★ Made in USA

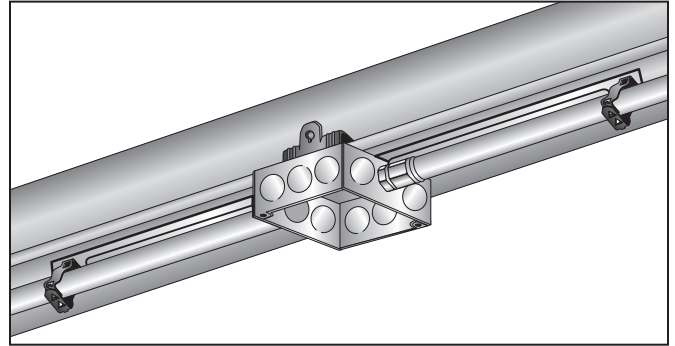

CBS18KC123418

- Provides conduit support on both sides of electrical box.
- Attaches to beam flanges from 1/8" to 1/2" thick.
- Made from pre-galvanized steel with Black Claw™ spring steel fasteners riveted to part.

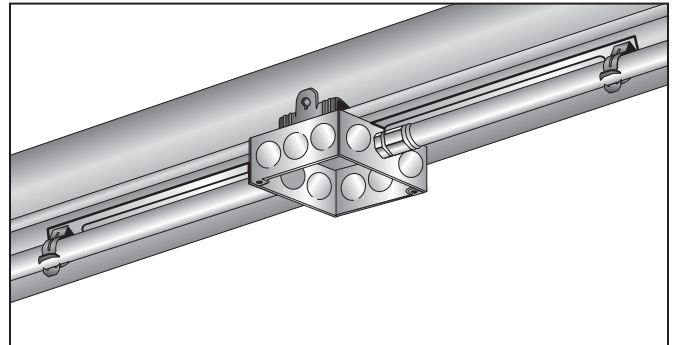

CBS18HIC10018

Mount 4" Square Boxes		Part #	Std Pkg
Conduit Size	Flange Thickness		
1/2" EMT	1/8-1/4	CBS18HIC5018 ★	25
3/8" EMT	5/16-1/2	CBS18HIC50516 ★	25
1/2"-3/4" or 1/2" Rigid	1/8-1/4	CBS18HIC7518 ★	25
1/2"-3/4" or 1/2" Rigid	5/16-1/2	CBS18HIC75516 ★	25
1" EMT or 3/4" Rigid	1/8-1/4	CBS18HIC10018 ★	25
1" EMT or 3/4" Rigid	5/16-1/2	CBS18HIC100516 ★	25

CONDUIT/CABLE SUPPORT

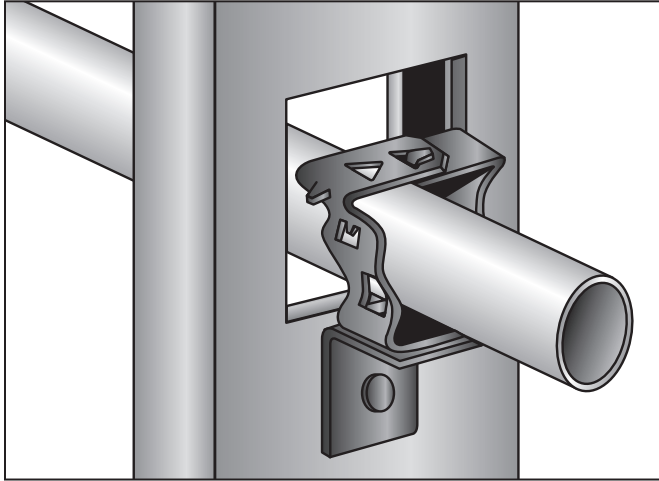

- Designed to secure horizontal runs of Rigid, EMT, AC, MC, BX or PVC through metal studs. 1/4" Mounting hole on bracket.



BAKC1234



BA50

Fits Conduit	Part #	Std Pkg
3/8" or BX	BAKC38 ★	100
1/2" or 3/4"	BAKC1234 ★	100
1/2" EMT	BA50 ★	100
3/4" EMT or 1/2" Rigid	BA75 ★	100

★ Made in USA

FLEXIBLE CONDUIT/CABLE FASTENER

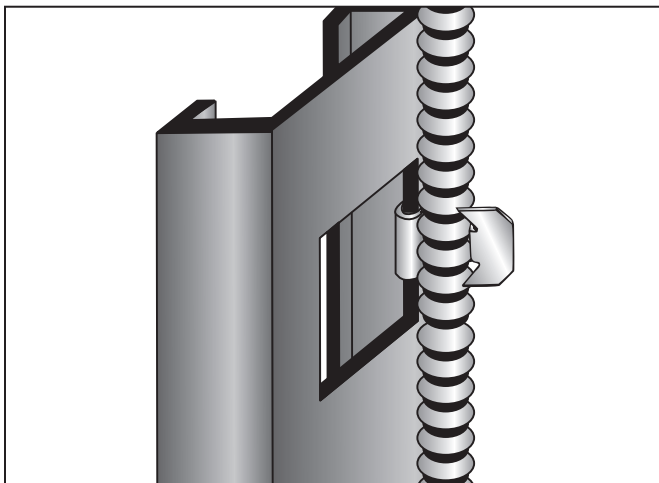

- Push clip attaches BX, MC or AC cable to metal studs.



BXC

Description	Part #	Std Pkg
MC, AC or BX to Metal Stud	BXC ★	100

★ Made in USA

- Secures conduit to most metal studs.
- Installed using a hammer only.



SBX

Description	Part #	Std Pkg
MC or BX (12-2 thru 10-3) to Metal Studs	SBX ★	100

★ Made in USA

CONDUIT TO STUD SUPPORT

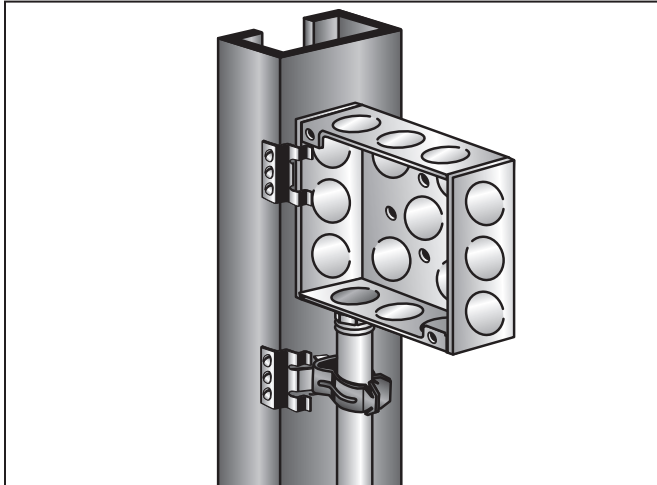

- Screw attached support for vertical runs of Rigid, EMT, or PVC to metal studs.
- See pages 214 and 244 for Far Side Box Support.

Fits EMT	Fits Rigid/IMC	Part #	Std Pkg
1/2	—	SS50 ★	100
3/4	1/2	SS75 ★	100
1	3/4	SS100 ★	100

Fits Conduit	Part #	Std Pkg
1/2 or 3/4	SSKC1234 ★	100
1	SSKC1 ★	100

★ Made in USA



SS75



SSKC1234

BOX TO STUD FASTENER

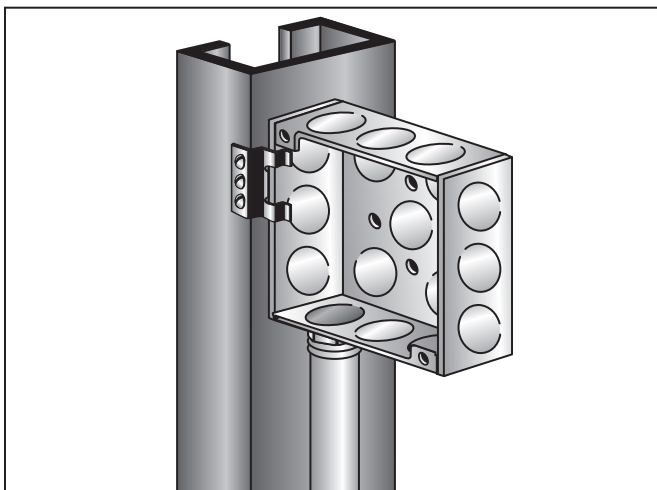

- Screw attached support for box and conduit. For use with either metal or wood studs.
- See pages 214 and 244 for Far Side Box Support.

Description	Part #	Std Pkg
Electrical Box Support Clip Secured with Self-Tapping Screws for Wood or Metal Studs	SS ★	100

★ Made in USA



SS

BOX TO STUD SUPPORT

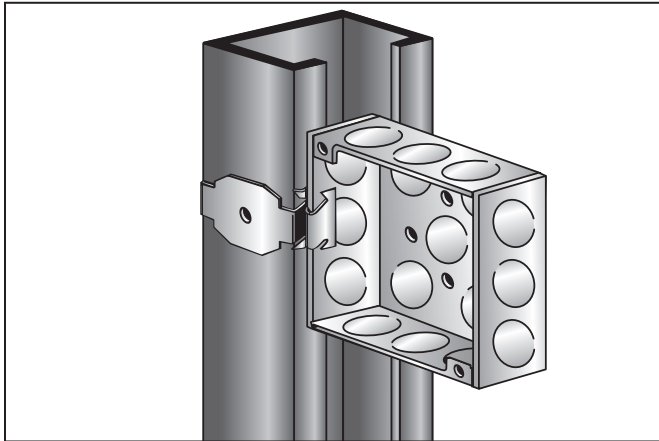

- Secures boxes to most metal studs.
- Installed using a hammer only.
- See pages 214 and 244 for Far Side Box Support.

Description	Part #	Std Pkg
Hammer Installed Electrical Box Support	S1900 ★	100

★ Made in USA



S1900

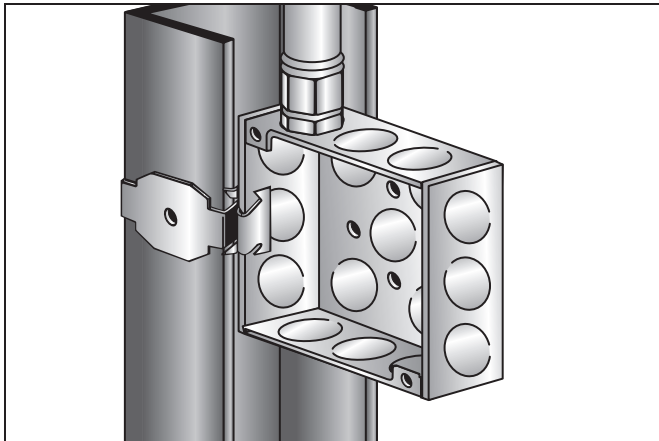

- Secures boxes to most metal studs.
- Series includes adjustable and preset versions.
- Installed using a hammer only.
- See pages 214 and 244 for Far Side Box Support.

Description	Part #	Std Pkg
Adjustable for 1/4" through 3/4" Drywall	SBC ★	100

★ Made in USA



SBC

CONDUIT TO STUD FASTENER

- Designed to quickly secure vertical runs of Rigid, EMT, AC, MC, BX or PVC to metal studs.

Fits EMT	Fits Rigid/IMC	Part #	Std Pkg
1/2	—	SB50 ★	100
3/4	1/2	SB75 ★	100
1	3/4	SB100 ★	100

Fits Conduit	Part #	Std Pkg
3/8 or BX	SBKC38 ★	100
1/2 or 3/4	SBKC1234 ★	100
1	SBKC1 ★	100

★ Made in USA

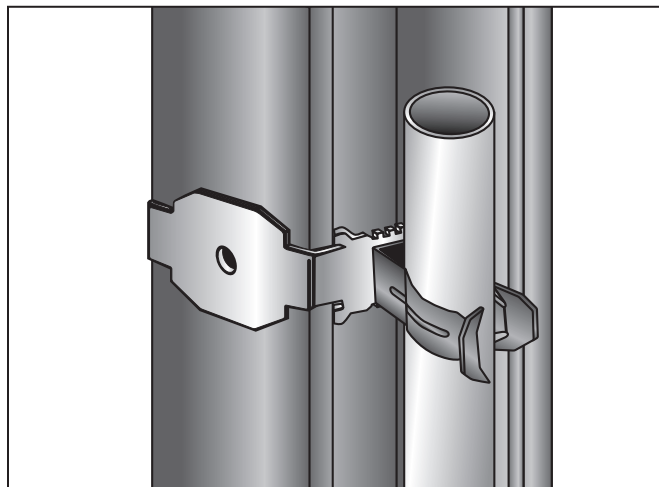

FAR SIDE BOX SUPPORT

- Clips on electrical boxes for additional support.

Metal Stud Size	Part #	Std Pkg
2 1/2" thru 4", Sized by Bending at Premarked Lines	SBS ★	100
3 1/2	SBS3.5 ★	100
6	SBS6 ★	100

★ Made in USA

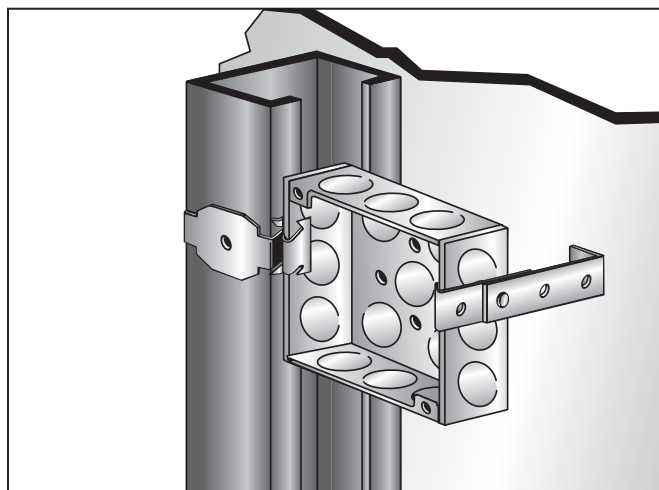

BOX MOUNTING BRACKET

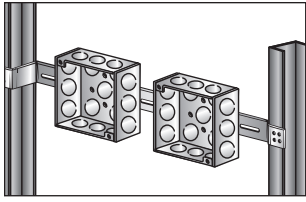

- Supports electrical boxes located between studs on 16" or 24" centers. Boxes attach using self-tapping screws.
- Made from pre-galvanized steel.

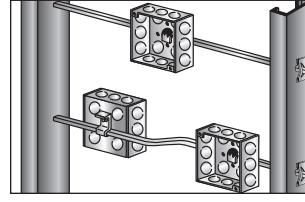

- Black Claw™ Spring Steel hardware is included.
- Bars made from pre-galvanized steel.



BMB16

Description	Part #
1½" Box to Studs on 16" Centers	BMB16 ★
2 1/8" Box to Studs on 16" Centers	BMB16D ★
1½" Box to Studs on 24" Centers	BMB24 ★
2 1/8" Box to Studs on 24" Centers	BMB24D ★

★ Made in USA



BAR

Description	Part #	Std Pkg
1 Straight 26"-Long Bar	BAR ★	50
1 BBC, 2 BSC		

★ Made in USA

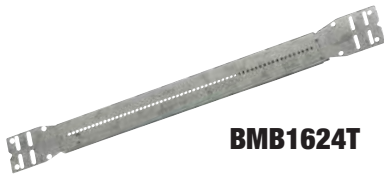

BMB1624T

Description	Part #
11-18" Mounting Bracket	BMB16T
17-26" Box Mounting Bracket	BMB24T
15 ½" to 25" Mounting Bracket	BMB1624T

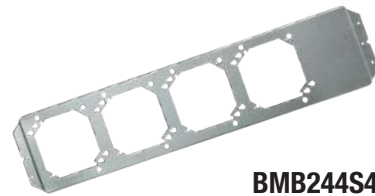

BMB244S4P

Description	Part #
16" Multi Box Mounting Bracket	BMB164S3P
24" Multi Box Mounting Bracket	BMB244S4P



BMB244SL

Description	Part #
16" Box Slider Mounting Bracket	BMB164SL
24" Box Slider Mounting Bracket	BMB244SL

BOX TO T-BAR FASTENER

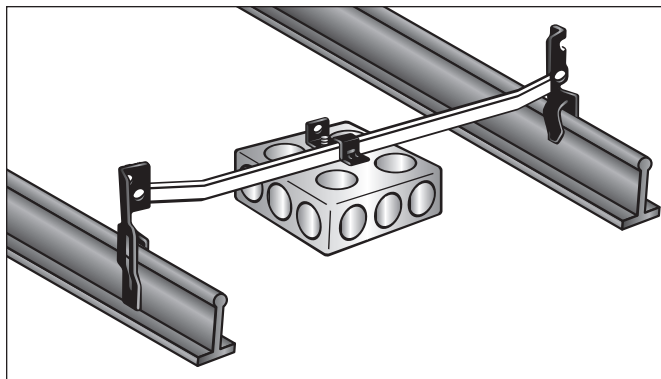

- Snap-on 24" span box hanger with dual height adjustment allows flush or 3/4" offset mount.
- Pre-galvanized steel with Black Claw™ spring steel hardware included.

Description	Part #	Std Pkg
24"-Long Box Hanger, 1 BBC Mounting Clip with Screw	TBAR	50
Heavy Duty T-Bar Box Bracket	TBARHD	25
3 5/8" Extension	TBARHDXT	50



TBARHD

LIGHTING SUPPORT ASSEMBLY

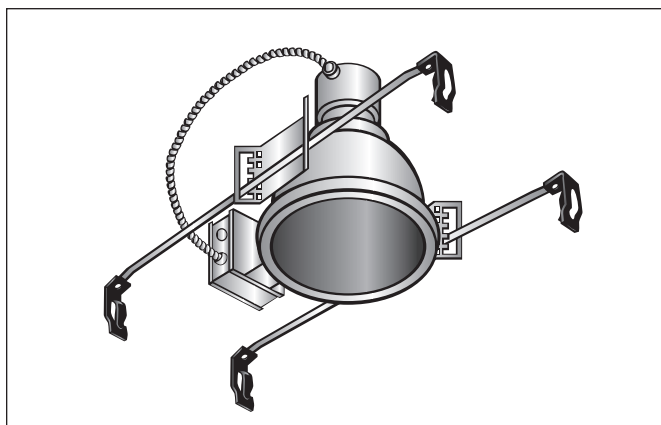

- Snap-on 24" fixed span with adjustable fixture position.
- Installed with screwdriver.
- Pre-galvanized steel with Black Claw™ spring steel hardware.

Description	Part #	Std Pkg
Fits LIGHTOILER 5 and CALCULITE® Series Fixtures	LSBAR ★	25 Sets

★ Made in USA



LSBAR

LIGHTING • TROFFER FASTENER

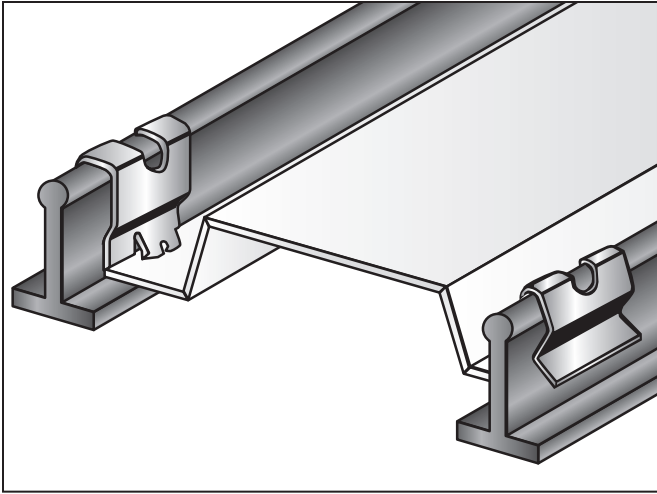

- Clip-on positive support for troffers and lay-in fixtures.
- Complies with 2011 NEC 410.36 (B) means of support.
- Fits round or rectangular head T-Bars.

Description	Part #	Std Pkg
T-bar Clip for Troffers	FT ★	100

★ Made in USA



FT

TWIST-ON T-BAR HANGER

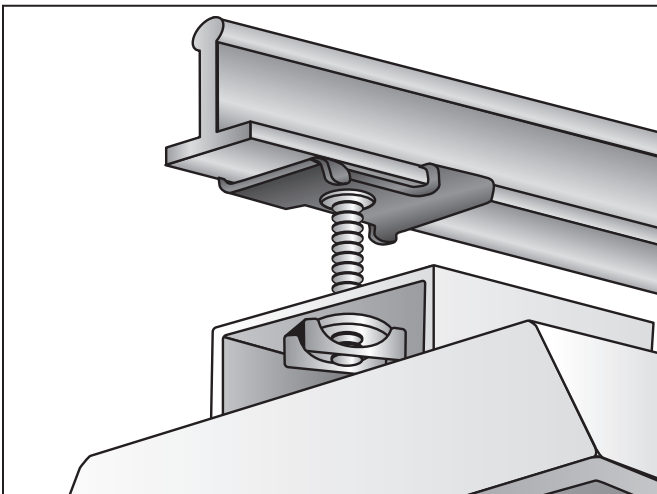

- Supports electrical fixtures to T-Bar $1\frac{5}{16}$ " wide.
- Assembled with 1" OD wing nut washer.
- $\frac{1}{4}$ "-20 stud $\frac{5}{8}$ " long.

Description	Part #	Std Pkg
Has $\frac{1}{4}$ "-20 x $\frac{5}{8}$ " Stud with Wing Nut Washer	SCT3	100



SCT3

T-BAR FASTENERS

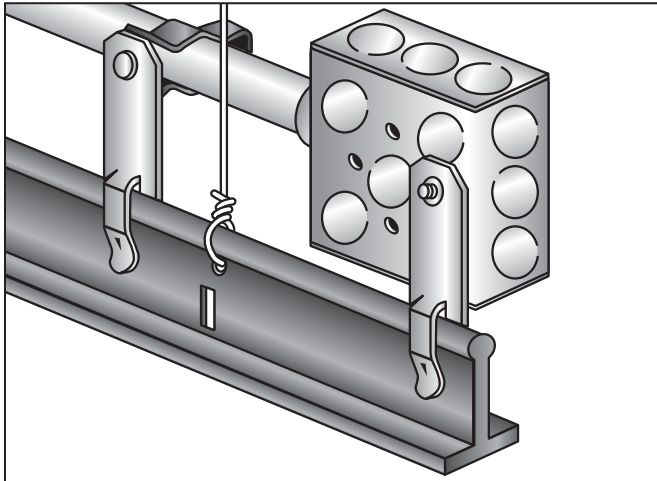

- Positive method of supporting conduit and outlet boxes above acoustical T-Bar.

Description	Part #	Std Pkg
With 1/4"-20 Thread Impression	TBT ★	100
With Plain Hole	TB ★	100

Description	Part #	Std Pkg
With Plain Hole	TS ★	100

★ Made in USA



BLACK CLAW

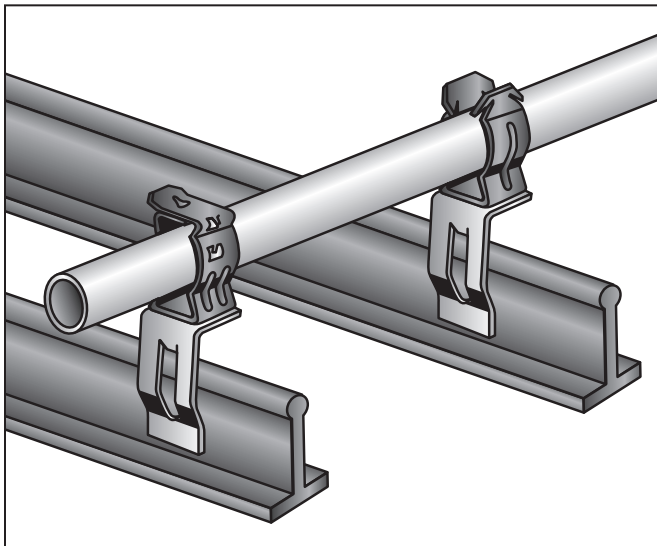

- Top mounted acoustical T-Bar fastener. Riveted assembly fits 3/8" to 1" conduit.
- Supports boxes and conduit above T-Bar.

Fits EMT	Fits Rigid/IMC	Part #	Std Pkg
1/2	—	TB50 ★	100
3/4	1/2	TB75 ★	100
1	3/4	TB100 ★	100

Fits Conduit	Part #	Std Pkg
3/8 or BX	TBKC38 ★	100
1/2, 3/4	TBKC1234 ★	100
1	TBKC1 ★	100

★ Made in USA



T-BAR FASTENERS (CONT.)

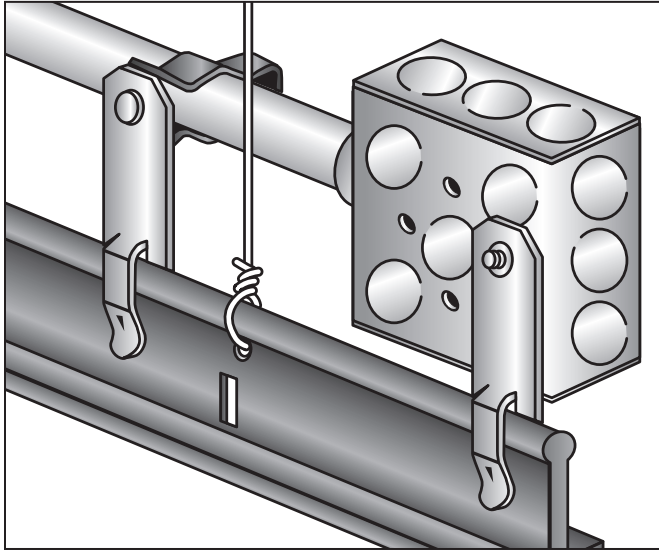

- Side mounted acoustical T-Bar fastener. Riveted assembly fits 3/8" to 1" conduit.

Fits EMT	Fits Rigid/IMC	Part #	Std Pkg
1/2	—	TS50 ★	100
3/4	1/2	TS75 ★	100
1	3/4	TS100 ★	100

Fits Conduit	Part #	Std Pkg
3/8 or BX	TSKC38 ★	100
1/2, 3/4	TSKC1234 ★	100
1	TSKC1 ★	100

★ Made in USA



TS50

BOX TO BAR FASTENER

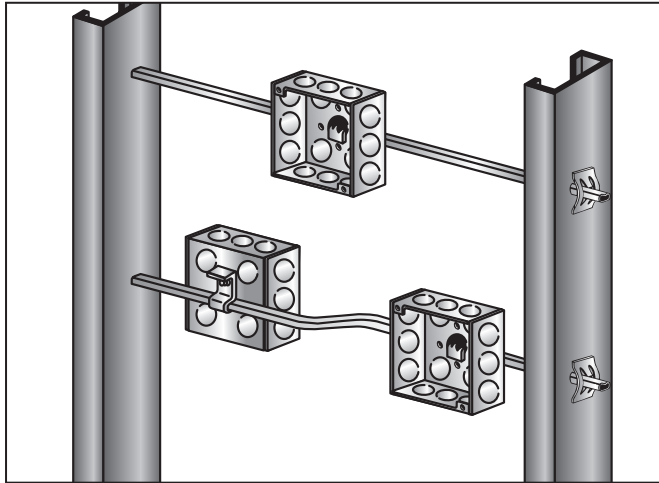

- Box to bar mounting clips.

Description	Part #	Std Pkg
Box Mounting Clip with Screw	BBC ★	100

★ Made in USA



Compatibility & Size Reference Charts

GALVANIC CORROSION COMPATIBILITY OF METALS

MATERIALS	Stainless Steel	Copper Plated Steel	Zinc Plated Steel	Aluminum	Spring Steel
Stainless Steel	Yes	No	Yes	Yes	Yes
Copper Plated Steel	No	Yes	No	No	No
Zinc Plated Steel	Yes	No	Yes	Yes	Yes
Aluminum	Yes	No	Yes	Yes	Yes
Spring Steel	Yes	No	Yes	Yes	Yes

RIGID STEEL CONDUIT (Heavy Wall Conduit)

Nominal Conduit Size	Outside Diameter (inches)	Nominal Inside Diameter (inches)	Min. Weight (lbs) per 100 ft w/Couplings Attached	Weight (lbs) of Conduit & Conductor per 100 ft
3/8	0.675	0.493	51.5	65.1
1/2	0.840	0.632	79.0	101.1
3/4	1.050	0.836	105.0	145.8
1	1.315	1.063	153.0	219.3
1 1/4	1.660	1.394	201.0	318.3
1 1/2	1.900	1.624	249.0	408.8
2	2.375	2.083	332.0	593.8
2 1/2	2.875	2.489	527.0	901.0
3	3.500	3.090	682.6	1259.0
3 1/2	4.000	3.570	831.0	1604.0
4	4.500	4.050	972.3	1967.0

RIGID ALUMINUM CONDUIT

- Dimensions taken from ANSI C80.3-1977.
- Conduit plus weight of heaviest conductor combination as specified by the National Electrical Code.

Nominal Conduit Size	Outside Diameter (inches)	Nominal Inside Diameter (inches)	Min. Weight (lbs) per 100 ft w/Couplings Attached	Weight (lbs) of Conduit & Conductor per 100 ft
1/2	0.840	0.632	27.4	49.5
3/4	1.050	0.836	36.4	84.3
1	1.315	1.063	53.0	130.3
1 1/4	1.660	1.394	69.6	212.3
1 1/2	1.900	1.624	82.2	269.8
2	2.375	2.083	115.7	401.8
2 1/2	2.875	2.489	182.5	579.0
3	3.500	3.090	238.9	626.3
3 1/2	4.000	3.570	287.7	1098.0
4	4.500	4.050	340.0	1364.0
5	5.563	5.073	465.4	2028.0
6	6.625	6.093	612.5	2870.0

Size Reference Charts

INTERMEDIATE METAL CONDUIT

Nominal Conduit Size	Outside Diameter (inches)	Nominal Inside Diameter (inches)	Min. Weight (lbs) per 100 ft w/Couplings Attached	Weight (lbs) of Conduit & Conductor per 100 ft
1/2	0.815	0.745	60.0	82.1
3/4	1.029	0.954	82.0	122.8
1	1.290	1.205	116.0	182.3
1 1/4	1.638	1.553	150.0	267.3
1 1/2	1.883	1.793	182.0	341.8
2	2.360	2.266	242.0	503.8
2 1/2	2.857	2.727	401.0	775.0
3	3.476	3.346	493.0	1069.0
3 1/2	3.971	3.841	573.0	1346.0
4	4.466	4.336	638.0	1632.0

ELECTRICAL METALLIC TUBING (EMT) (Thin Wall Conduit)

- Dimensions taken from ANSI C80.3-1977.
- Conduit plus weight of heaviest conductor combination as specified by the National Electrical Code.

Nominal Conduit Size	Outside Diameter (inches)	Nominal Inside Diameter (inches)	Min. Weight (lbs) per 100 ft w/Couplings Attached	Weight (lbs) of Conduit & Conductor per 100 ft
3/8	0.577	0.493	23.0	36.6
1/2	0.706	0.622	28.5	50.6
3/4	0.922	0.824	43.5	84.3
1	1.163	1.049	64.0	130.3
1 1/4	1.510	1.380	95.0	212.3
1 1/2	1.740	1.610	110.0	269.8
2	2.197	2.067	140.0	401.8
2 1/2	2.875	2.731	205.0	579.0
3	3.500	3.356	250.0	626.3
3 1/2	4.000	3.834	325.0	1098.0
4	4.500	4.334	370.0	1364.0

SCHEDULE 40 PVC PLASTIC PIPE

Nominal Pipe Size	Outside Diameter (inches)	Wall Thickness (inches)	Weight of Pipe (lbs/ft)	Weight of Water (lbs/ft)
1/8	.405	.068	.04	.02
1/4	.540	.088	.07	.04
3/8	.675	.091	.10	.08
1/2	.840	.109	.15	.1
3/4	1.050	.113	.2	.2
1	1.315	.133	.3	.4
1 1/4	1.660	.140	.4	.6
1 1/2	1.900	.145	.5	.9
2	2.375	.154	.6	1.4
2 1/2	2.875	.203	1.0	2.1
3	3.500	.216	1.3	3.2
3 1/2	4.000	.226	1.6	4.3
4	4.500	.237	1.9	5.5

DIMENSION ALL THREAD ROD (ATR)

- Dimensions taken from ANSI B1.1-1982 Unified Inch Screw Threads.
- All threads are UNCR series.
- Tabulated loads are based on an allowable tensile stress of 12000 psi (82.7 MPa) reduced by 25% resulting in 9000 psi (62 MPa). From ANSI/MSS SP-58, Table 3.

Nominal Size & Thread	Root Area		Design Load (SF=5)	
	in. ²	cm ²	lbs	kN
1/4 - 20	0.027	0.174	240	1.07
5/16 - 18	0.045	0.290	400	1.78
3/8 - 16	0.068	0.438	610	2.71

The Right Staple For The Job

The Impact Staples line offers residential insulated and non-insulated staples. Our most popular sizes of metal staples come with the standard dimple at the top—or try our “flat top” version. All plastic staples are made from high quality UV stabilization material for protection against harsh environments.

Minerallac Company's entire Impact Staples line is made in the U.S.A.

346 Packaging Options

347 Non-Insulated Metal Staples

348 Insulated Metal Staples

349-350 Insulated Plastic Staples



PACKAGING OPTIONS

Impact™ staples are packaged in conveniently sized individual boxes. Our most popular styles of Impact™ staples are available in boxes, kraft bags, jars or bulk packed in kegs and reusable plastic pails.



PLASTIC PAILS

Try Impact™ staples in our unique square-shaped pails. This weather-tight, sturdy, tip-resistant pail is easy to carry from job to job and has various other storage uses once the pail is empty.

SQUARE JARS

New square jars with finger indent for pouring ease.



IMPACT STAPLES

INSULATED PLASTIC IMPACT™ STAPLES

- Provide secure mounting without damage to wire and cable.
- Zinc plated nails are designed to minimize wood splitting.
- Pre-positioned nails ensure quick installation, even in vertical and overhead positions.

- Box, bag, jars or bulk packed.
- Available in reusable plastic pails.
- Staples are made from high impact UV stabilized material for severe weather conditions.

NON-INSULATED & INSULATED METAL IMPACT™ STAPLES

- Leg design minimizes wood splitting.
- Staples are deburred and polished.
- Rust inhibitor applied for longer shelf life.
- Box, jars or bulk packed.
- Available in reusable plastic pails.

- Heavy-Duty 1" x 1/2" available to help eliminate "bending" when driven into hard wood.
- Flat Top" Version available for 1" x 1/2" and 1 1/4" x 9/16".
- Two types of insulated metal cable staples available for 1" x 1/2" and 1 1/4" x 9/16" sizes. PVC dipped and with Plastic Insulator, both in optic blue for high visibility.

CABLE STAPLES

Cable Size: 2 Conductor (#12 & #14) Romex® and other type NM cable.

Style (L x W)	Part #	Pkg Qty (Pcs)	Shipper (Pcs)
Standard 1" x 1/2"	I10A ★	Box of 100	10,000
	I10C ★	Box of 500	5,000
	I10G ★	Jar of 500	3,000
	I10R ★	Pail of 5,000	5,000
Standard HEAVY DUTY 1" x 1/2"	I10HA ★	Box of 100	10,000
	I10HC ★	Box of 500	5,000
	I10HG ★	Jar of 500	3,000
	I10HR ★	Pail of 5,000	5,000
Flat Top HEAVY DUTY 1" x 1/2"	I10HFA ★	Box of 100	10,000
	I10HFC ★	Box of 500	5,000
	I10HFG ★	Jar of 500	3,000
	I10HFR ★	Pail of 5,000	5,000

Cable Size: S.E.U. 6/3 Cable

L x W	Part #	Pkg Qty (Pcs)	Shipper (Pcs)
1 5/16" x 3/4"	I13A ★	Box of 100	2,000

Cable Size: S.E.U. 2/3 Cable

L x W	Part #	Pkg Qty (Pcs)	Shipper (Pcs)
1 1/2" x 1"	I15A ★	Box of 100	2,000

★ Made in USA

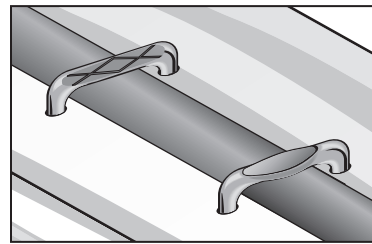

Cable Size: 3 Conductor (#10, #12 & #14) Romex®, BX, MC and other cable.

Style (L x W)	Part #	Pkg Qty (Pcs)	Shipper (Pcs)
Standard 1 1/4" x 9/16"	I12A ★	Box of 100	5,000
	I12C ★	Box of 500	5,000
	I12G ★	Jar of 500	3,000
	I12R ★	Pail of 5,000	5,000
	I12S ★	Pail of 7,500	7,500
Flat Top 1 1/4" x 9/16"	I12FA ★	Box of 100	5,000
	I12FC ★	Box of 500	5,000
	I12FG ★	Jar of 500	3,000
	I12FR ★	Pail of 5,000	5,000

SERVICE ENTRANCE STAPLES

Cable Size: 6/3 S.E. 8-3 BX Range Cords

L x W	Part #	Pkg Qty (Pcs)	Shipper (Pcs)
1 3/8" x 1 3/16"	ISE13A ★	Box of 100	2,000

Cable Size: 4/3 S.E.R. 2/3 S.E. 3/4" EMT

L x W	Part #	Pkg Qty (Pcs)	Shipper (Pcs)
1 7/16" x 1 1/16"	ISE14A ★	Box of 100	1,000

Cable Size: 2/0 S.E., 1" EMT

L x W	Part #	Pkg Qty (Pcs)	Shipper (Pcs)
1 7/8" x 1 11/32"	ISE18U ★	Box of 50	1,000

★ Made in USA



Cable Size: 2/3 BX, 1" EMT, 1" Greenfield, 2/3 SER

L x W	Part #	Pkg Qty (Pcs)	Shipper (Pcs)
2 1/4" x 1 3/16"	ISE22U ★	Box of 50	1,000

Cable Size: 4/0 S.E. Greenfield, Large BX, Romex®, Tubing

L x W	Part #	Pkg Qty (Pcs)	Shipper (Pcs)
2 1/8" x 1 5/8"	ISE23U ★	Box of 50	500

PLASTIC INSULATOR CABLE STAPLES



Standard

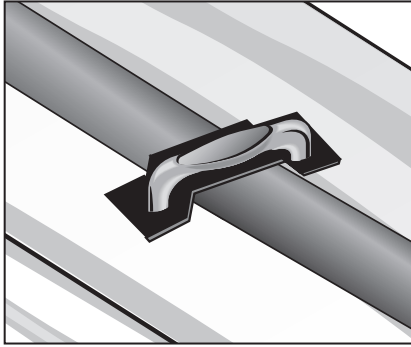

Flat Top

- Highly visible optic blue plastic insulator.
- Standard or flat top staple style.
- Packed in boxes and square plastic pails.

Cable Size: 2 Conductor (#12 & #14) Romex®, and other type NM cable.

Style and Size (L x W)	Part #	Pkg Qty (Pcs)	Shipper (Pcs)
Standard 1" x 1/2"	IPN1A ★	Box of 100	2,000
	IPN1C ★	Box of 500	5,000
	IPN1R ★	Pail of 5,000	5,000
Flat Top HEAVY DUTY 1" x 1/2"	IPN1HFA ★	Box of 100	2,000
	IPN1HFC ★	Box of 500	5,000

Cable Size: 3 Conductor (#10, #12 & #14) Romex®, BX, MC and other cable.

Style and Size (L x W)	Part #	Pkg Qty (Pcs)	Shipper (Pcs)
Standard 1 1/4" x 9/16"	IPN2A ★	Box of 100	2,000
	IPN2C ★	Box of 500	5,000
	IPN2R ★	Pail of 5,000	5,000
Flat Top 1 1/4" x 9/16"	IPN2FA ★	Box of 100	2,000
	IPN2FC ★	Box of 500	2,500
	IPN2FR ★	Pail of 5,000	5,000

★ Made in USA

PVC DIPPED CABLE STAPLES



IPVC1HA

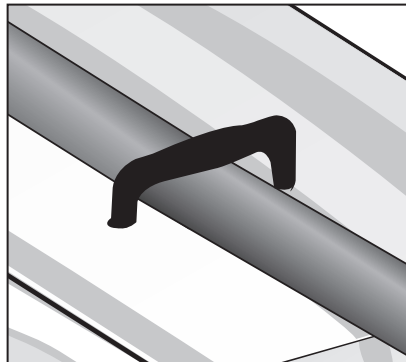

IPVC2A

- Top of staple dipped in high impact hot melt PVC.
- Highly visible optic blue.
- Packed in boxes, jars and square plastic pails.

Cable Size: 2 Conductor (#12 & #14) Romex®, and other type NM cable.

Style and Size (L x W)	Part #	Pkg Qty (Pcs)	Shipper (Pcs)
HEAVY DUTY 1" x 1/2"	IPVC1HA ★	Box of 100	2,000
	IPVC1HC ★	Box of 500	5,000
	IPVC1HF ★	Jar of 350	2,100
	IPVC1HR ★	Pail of 5,000	5,000

Cable Size: 3 Conductor (#10, #12 & #14) Romex®, BX, MC and other cable.

Size (L x W)	Part #	Pkg Qty (Pcs)	Shipper (Pcs)
1 1/4" x 9/16"	IPVC2A ★	Box of 100	2,000
	IPVC2C ★	Box of 500	5,000
	IPVC2F ★	Jar of 350	2,100
	IPVC2R ★	Pail of 5,000	5,000

★ Made in USA

IMPACT STAPLES

PLASTIC CABLE STAPLES

Cable Size: 2 & 3-wire NM cable up to #12, 2-wire UF cable up to #12 and other cable up to 1/2" wide.

Color	Part #	Pkg Qty (Pcs)	Shipper (Pcs)
White	IPS50A ★	Box of 100	1,000
	IPS50C ★	Box of 500	2,500
	IPS50E ★	Jar of 200	1,200
	IPS50P ★	Pail of 2,000	2,000
	IPS50K ★	Kraft Bag of 500	2,500

★ Made in USA

Cable Size: 2-wire NM and UF cable up to #8, 3-wire UF cable up to #12 and other cable up to 3/4" wide.

Color	Part #	Pkg Qty (Pcs)	Shipper (Pcs)
White	IPS75A ★	Box of 100	1,000
	IPS75C ★	Box of 500	2,500
	IPS75D ★	Jar of 150	900
	IPS75P ★	Pail of 2,000	2,000
	IPS75L ★	Kraft Bag of 500	2,500

★ Made in USA

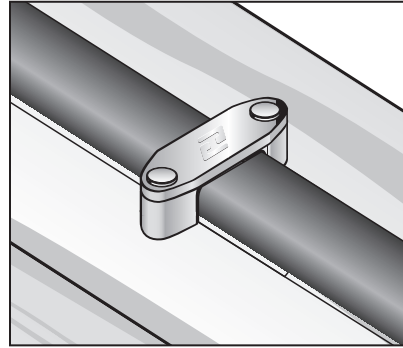

IPS50

- Our top selling insulated staples.
- For 1/2" and 3/4" wide single cables.
- UL Listed.
- Made from UV stabilized high impact plastic.



IPS75

SERVICE ENTRANCE STAPLES • STYLE SER



ISER40

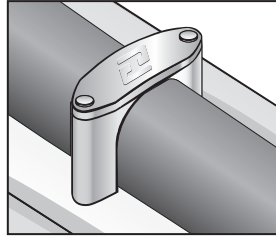

- All staples are UV stabilized for severe weather conditions.
- Zinc plated nails made from high carbon steel for strength and durability.

Cable Size: #6 Type SE, Style SER, 1/2" EMT (.718" Diameter)

Color	Part #	Pkg Qty (Pcs)	Shipper (Pcs)
Gray	ISER10 ★	Box of 50	500

Cable Size: #2 Type SE, Style SER, 3/4" EMT (.937" Diameter)

Color	Part #	Pkg Qty (Pcs)	Shipper (Pcs)
Gray	ISER20 ★	Box of 25	250

Cable Size: #2/0 Type SE, Style SER, 1" EMT (1.160" Diameter)

Color	Part #	Pkg Qty (Pcs)	Shipper (Pcs)
Gray	ISER30 ★	Box of 25	250

Cable Size: #4/0 Type SE, Style SER, (1.438" Diameter)

Color	Part #	Pkg Qty (Pcs)	Shipper (Pcs)
Gray	ISER40 ★	Box of 10	100

★ Made in USA

BELL & THERMOSTAT STAPLES



IBT251W

- Available in black and white.
- All staples are UV stabilized for severe weather conditions.
- Zinc plated nails made from high carbon steel for strength and durability.

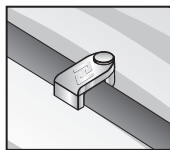

Cable Size: 1/4" 1-Nail

Color	Part #	Pkg Qty (Pcs)	Shipper (Pcs)
Black	IBT251B ★	Box of 100	1,000
White	IBT251W ★	Box of 100	1,000

★ Made in USA

SERVICE ENTRANCE STAPLES • STYLE SEU



ISEU50

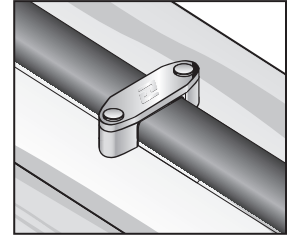

- All staples are UV stabilized for severe weather conditions.
- Zinc plated nails made from high carbon steel for strength & durability.

Cable Size: #6 Type SE, Style SEU, (.437" x .750")

Color	Part #	Pkg Qty (Pcs)	Shipper (Pcs)
Gray	ISEU50 ★	Box of 50	500

Cable Size: #2 Type SE, Style SEU, (.550" x .972")

Color	Part #	Pkg Qty (Pcs)	Shipper (Pcs)
Gray	ISEU60 ★	Box of 50	500

Cable Size: #2/0 Type SE, Style SEU, (.775" x 1.265")

Color	Part #	Pkg Qty (Pcs)	Shipper (Pcs)
Gray	ISEU70 ★	Box of 25	500

Cable Size: #4/0 Type SE, Style SEU, (.855" x 1.500")

Color	Part #	Pkg Qty (Pcs)	Shipper (Pcs)
Gray	ISEU80 ★	Box of 25	250

NON-METALLIC SHEATHED CABLE STAPLES



INS66

- All staples are UV stabilized for severe weather conditions.
- Zinc plated nails made from high carbon steel for strength and durability.

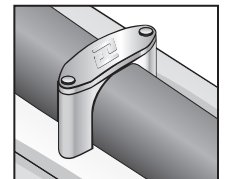

Cable Size: For 3-wire #8 and #6 NM cable and other cable up to 2 1/32" wide.

Color	Part #	Pkg Qty (Pcs)	Shipper (Pcs)
Gray	INS66 ★	Box of 100	1,000

Staples, Nails, and Wire

Redmore offers popular sizes of utility staples with diamond or cut points in bright wire, mechanical galvanized or copperclad finishes.

Minerallac Company's entire Redmore® line is made in the U.S.A.

352 General Product Information

353–357 Diamond Point Staples

358–359 Cut Point Staples

360 Nails

361 Standard Gauge Wire Chart



MANUFACTURING MATERIALS

Bright Wire – Bright Wire has no finish. Parts made from this material are recommended for applications where there is no issue with respect to corrosion as a result of exposure to harsh or outdoor environments.

Pre-Galvanized – Mill or Pre-Galvanized wire has a factory bonded zinc coating applied to a bright wire base. Parts made from this material are afforded a minimum zinc protection on uncut surfaces of .000159.

Copperclad – Copperclad wire has a factory bonding of copper material to a bright wire base. This copperclad wire provides excellent corrosion protection for parts made from it and is preferred over coatings. The copper thickness is a minimum of 6% of the wire radius. This finish provides .00349 to .00739 thickness depending on the wire diameter.

FINISHES

Electro-Zinc Plated – Bright wire parts are electro-zinc plated after forming. This plating provides a minimum zinc coating of .000159 applied to all surfaces.

Mechanical Galvanized – We coat our staples to Class 50, Type 1. Which is .0029 of zinc and is 13 times greater in thickness than conventional electro-zinc coatings mechanical galvanized finish will withstand 300 hours to red rust in a 5% neutral salt spray test.

MANUFACTURING OPTIONS

Additional sizes and styles of Redmore® products are available. Please contact customer service.

Staples – Redmore® Staples are produced with Diamond (rolled) points, Cut (slash points) or Flat (chisel) points. Contact sales for information and pricing on Flat Point Staples.

Most staples are produced with smooth wire, but our serrated diamond point or cut point staples are manufactured with grooves in the legs of the staples to increase holding power and reduce back-out problems.

Nails – We offer common nails in a variety of wire gauges in both hot-dipped galvanized and copperclad. We also offer roofing nails in two different sizes and a variety of pole marking nails including pole class, pole height, dating and delta inspection.

PACKAGING OPTIONS

Special Packaging/Label Options – Redmore® is geared to customer service. Two available services include special packaging and custom labeling. Contact sales to discuss packaging options.

Special Size Requirements – We carry a large quantity of the most popular sizes. We also carry many sizes not shown in our catalog. If we do not carry the size you require, as a manufacturer, we have the capability to produce custom sizes if sufficient quantities are needed. Please contact sales to discuss specifications, production and plating minimums, set up charges and freight costs.

Bulk Packaging – All cut point staples are packed economically in bulk (loose staples packed in 50 lb. kegs.) Bright wire diamond point staples are also available packed in bulk.

Wire Size

Wire Diameter	Part # Letter	Gauge	Inches
.114	C	—	—
.120	E	11	—
.144	I	—	—
.148	K	9	—
.162	Q	8	—
.187	S	6	3/16"
.250	W	—	—

STAPLE MEASURING GUIDE

The following measurements correspond to those found at the top of the following pages:

Dimension A (Overall Length) – Measurement taken from top of staple to it's tip.

Dimension B (Inside Spread) – Measurement taken towards top of staple as indicated.

Dimension C (Wire Diameter) – Diameter of wire used in forming the staple. (See Wire Guide Reference on page 268.)

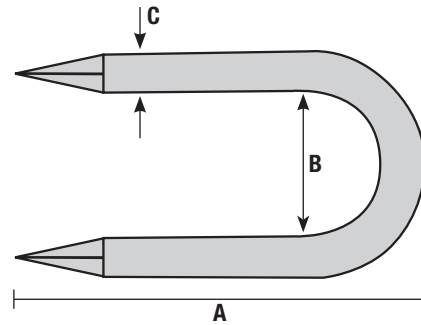

Diamond (Rolled) Point Staple

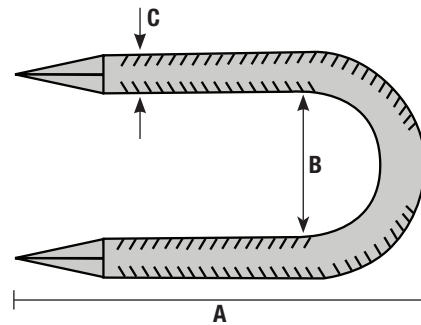

Serrated Diamond (Rolled) Point Staple

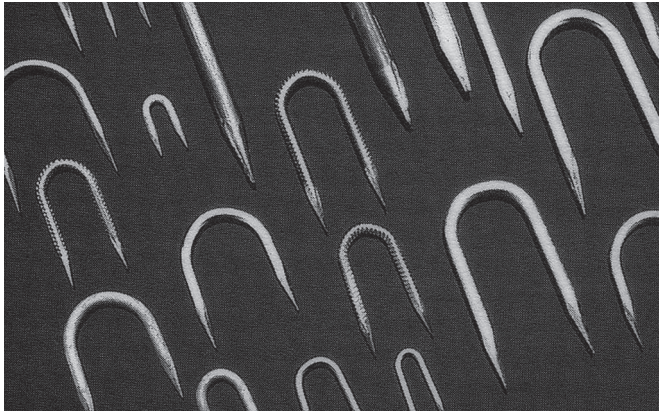

SQUARE WIRE BARBED STAPLES • BOX PACK



- Pounds per box is approximate and can vary + or – 10% depending on variances in wire weights and tolerances of staples during manufacture.

A	B	C					
Overall Length	Inside Spread	Wire Diameter	Part #	MOQ	Pcs/Box	Boxes/ Carton	Approximate lbs/Box
Mechanical Galvanized							
1½	¾	.131	CG1538M(B) ★ ♡	—	350	5	5.0
2	¾	.131	CG2038M(B) ★ ♡	35,000	260	5	5.0
2	⅝	.165	CG2063T(B) ★ ♡	—	160	5	5.0
3	1⅛	.218	CG3090N(B)* ★ ♡	9,000	60	5	5.0
Copperclad**							
1½	¾	.140	CC1538P(B) ★	—	300	5	4.8

*MOQ (Minimum Order Quantity)

**Due to volatility of copper market, please contact customer service for pricing.

★ Made in USA

♡ Harsh Environment Product

For 50lb keg packaging, contact customer service for quantities and availability.

BRIGHT WIRE DIAMOND POINT STAPLES • BOX PACK



- Pounds per box is approximate and can vary + or – 10% depending on variances in wire weights and tolerances of staples during manufacture.

A	B	C	Part #	MOQ	Pcs/Box	Boxes/ Carton	Approximate lbs/Box
Overall Length	Inside Spread	Wire Diameter					
1½	⅜	.148	DB1538K ★	15,000	100	10	1.28
1½	½	.148	DB1550K ★	15,000	100	10	1.30
1¾	⅜	.148	DB1738K ★	12,000	100	10	1.58
1¾	⅝	.162	DB1763Q ★	10,000	100	10	1.92
2	⅜	.120	DB2038E ★	—	100	10	1.29
2	½	.162	DB2050Q ★	—	100	10	2.13
2	⅝	.162	DB2063Q ★	10,000	100	10	2.22
2	⅝	.187	DB2063S ★	—	100	10	2.82
2	¾	.187	DB2075S ★	—	100	10	2.89
2½	¾	.187	DB2575S ★	—	100	10	3.64
2½	29/32	.187	DB2588S ★	—	100	10	3.77
2½	1¼	.187	DB2592S ★	—	100	10	3.90
3	¾	.187	DB3075S ★	—	100	5	4.50
3	1⅛	.250	DB3090W ★	—	100	5	7.52
3	1½	.250	DB3095W ★	—	100	5	7.84
3	1¾	.250	DB3097W ★	—	100	5	8.16
4	1¾	.250	DB4097W* ★	5,000	50	5	5.27

*MOQ (Minimum Order Quantity)

★ Made in USA

For 50lb keg packaging, contact customer service for quantities and availability.

BRIGHT WIRE DIAMOND POINT STAPLES • BULK PACK • 50LB KEG



- Pounds per box is approximate and can vary + or – 10% depending on variances in wire weights and tolerances of staples during manufacture.

A	B	C	Part #	MOQ	 Approximate Pcs/50 lb Keg	Approximate Pcs/lb
Overall Length	Inside Spread	Wire Diameter				
1½	¾	.148	DB1538K-B50 ★	200 lbs	3900	78
1½	½	.148	DB1550K-B50 ★	200 lbs	3850	77
1¾	¾	.148	DB1738K-B50 ★	200 lbs	3250	65
1¾	⅝	.162	DB1763Q-B50 ★	200 lbs	2600	52
2	¾	.120	DB2038E-B50 ★	—	4150	83
2	½	.162	DB2050Q-B50 ★	—	2350	47
2	⅝	.162	DB2063Q-B50 ★	200 lbs	2250	45
2	⅝	.187	DB2063S-B50 ★	—	1750	35
2	¾	.187	DB2075S-B50 ★	—	1750	35
2½	¾	.187	DB2575S-B50 ★	—	1400	28
2½	²⁹ / ₃₂	.187	DB2588S-B50 ★	—	1350	27
2½	1¼	.187	DB2592S-B50 ★	—	1250	25
3	¾	.187	DB3075S-B50 ★	—	1100	22
3	1⅙	.250	DB3090W-B50 ★	—	650	13
3	1½	.250	DB3095W-B50 ★	—	650	13
3	1¾	.250	DB3097W-B50 ★	—	600	12

*MOQ (Minimum Order Quantity)

★ Made in USA

ELECTRO-ZINC DIAMOND POINT STAPLES • BOX PACK



- Pounds per box is approximate and can vary + or – 10% depending on variances in wire weights and tolerances of staples during manufacture.

A	B	C	Part #	MOQ	Pcs/Box	Boxes/ Carton	Approximate lbs/Box
Overall Length	Inside Spread	Wire Diameter					
1¾	¾	.148	DZ1738K ★	—	100	10	1.55
2	⅝	.162	DZ2063Q ★	—	100	10	2.18
3	1⅙	.250	DZ3090W* ★	30,000	100	5	7.47

*MOQ (Minimum Order Quantity)

★ Made in USA

GALVANIZED DIAMOND POINT STAPLES • BOX PACK

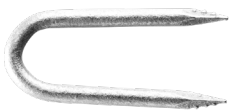

**Double Barbed
DG3090W(H)

• Pounds per box is approximate and can vary + or – 10% depending on variances in wire weights and tolerances of staples during manufacture.

A	B	C					
Overall Length	Inside Spread	Wire Diameter	Part #	MOQ	Pcs/Box	Boxes/ Carton	Approximate lbs/Box
1½	⅜	.148	DG1538K ★ ♡	—	100	10	1.38
1½	¾	.120	DG1575E ★ ♡	—	100	10	1.00
2	½	.162	DG2050Q ★ ♡	—	100	10	2.22
2	⅝	.162	DG2063Q ★ ♡	—	100	10	2.25
2	¾	.187	DG2075S ★ ♡	—	100	10	3.40
2	1⅓	.187	DG2090S* ★ ♡	30,000	100	10	3.50
2½	29/32	.187	DG2588S ★ ♡	—	100	10	3.85
2½	1⅓	.187	DG2590S* ★ ♡	15,000	100	10	3.85
3	1⅓	.250	DG3090W ★ ♡	—	100	5	7.96
3	1⅓	.250	DG3090W(H)** ★ ♡	—	100	5	7.69
3	1¾	.250	DG3097W* ★ ♡	7,000	100	5	8.50
3½	1¾	.250	DG3597W* ★ ♡	7,000	50	5	4.76

*MOQ (Minimum Order Quantity)

**Double barbed

★ Made in USA

♡ Harsh Environment Product

COPPERCLAD DIAMOND POINT STAPLES • BOX PACK



• Due to volatility of copper market, please contact customer service for pricing.

• Pounds per box is approximate and can vary + or – 10% depending on variances in wire weights and tolerances of staples during manufacture.

A	B	C					
Overall Length	Inside Spread	Wire Diameter	Part #	MOQ	Pcs/Box	Boxes/ Carton	Approximate lbs/Box
1	¼	.114	DC1025C ★	—	500	10	2.50
1¼	¼	.114	DC1225C ★	—	500	10	3.21
1½	⅙	.144	DC1531I ★	—	500	5	6.20
1¾	⅜	.144	DC1738I ★	—	500	5	7.46
2	½	.162	DC2050Q ★	—	100	10	2.17
2	⅝	.162	DC2063Q ★	—	100	10	2.22
2	⅝	.187	DC2063S ★	4,000	100	10	2.89

★ Made in USA

For 50lb keg packaging, contact customer service for quantities and availability.

DRIVE STOP® DIAMOND POINT STAPLES • BOX PACK



All Drive Stop® staples fitting #4 wire have a grey Drive Stop™.



All Drive Stop® staples fitting #6 wire have a black Drive Stop™.

- Pounds per box is approximate and can vary + or – 10% depending on variances in wire weights and tolerances of staples during manufacture.

★ Made in USA
 ⚡ Harsh Environment Product

A	B	C	Part #	Pcs/Box	Boxes/ Carton	Approximate lbs/Box
Overall Length	Inside Spread	Wire Diameter				
For #4 AWG Ground Wire						
2	5/8	.162	DG2063Q-#4 ★ ⚡	100	5	3.20
For #6 AWG Ground Wire						
2	5/8	.162	DG2063Q-#6 ★ ⚡	100	5	3.30

SERRATED ELECTRO-ZINC DIAMOND POINT STAPLES • BOX PACK



- Pounds per box is approximate and can vary + or – 10% depending on variances in wire weights and tolerances of staples during manufacture.

A	B	C	Part #	Pcs/Box	Boxes/ Carton	Approximate lbs/Box
Overall Length	Inside Spread	Wire Diameter				
2	5/8	.187	DZ2063S(S) ★	100	10	2.81

*MOQ (Minimum Order Quantity)

★ Made in USA

ELECTRO-ZINC FLAT TOP DIAMOND POINT STAPLE

A	B	C	Part #	Pcs/Box	Boxes/ Carton	Approximate lbs/Box
Overall Length	Inside Spread	Wire Diameter				
2	5/8	.162	DZ2063Q(F) ★	100	10	2.24
2	5/8	.162	DZ2063Q(F)-X2 ★	89	10	2.00

★ Made in USA

SERRATED GALVANIZED DIAMOND POINT STAPLES • BOX PACK



- Pounds per box is approximate and can vary + or – 10% depending on variances in wire weights and tolerances of staples during manufacture.

A	B	C	Part #	Pcs/Box	Boxes/ Carton	Approximate lbs/Box
Overall Length	Inside Spread	Wire Diameter				
1 1/4	3/8	.148	DG1738K(S) ★ ⚡	100	10	1.57

★ Made in USA

⚡ Harsh Environment Product

STAPLE MEASURING GUIDE

The following measurements correspond to those found at the top of the following pages:

Dimension A (Overall Length) – Measurement taken from top of staple to its tip.

Dimension B (Inside Spread) – Measurement taken towards top of staple as indicated.

Dimension C (Wire Diameter) – Diameter of wire used in forming the staple. (See Wire Guide Reference on page 268.)

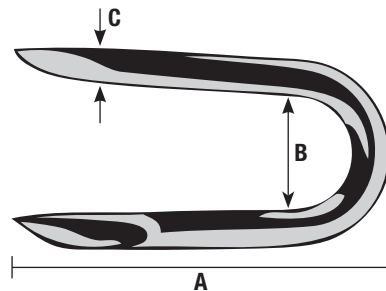
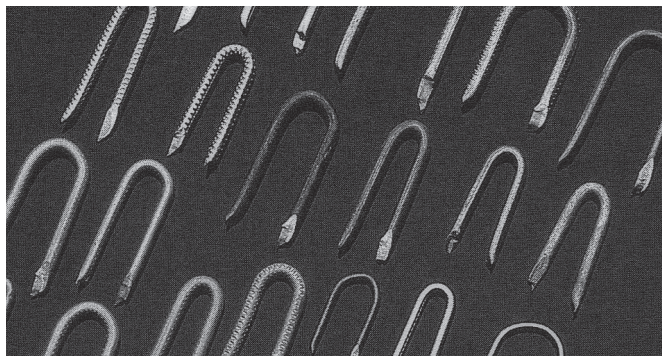

Cut (Slash) Point Staple

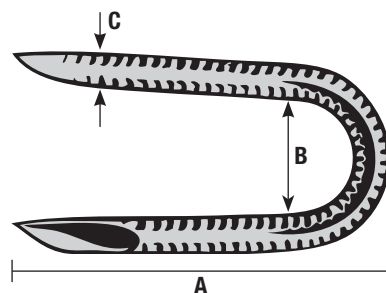

Serrated Cut (Slash) Point Staple

PRE-GALVANIZED CUT POINT STAPLES • BULK PACK • 50LB KEG



- Pounds per box is approximate and can vary + or – 10% depending on variances in wire weights and tolerances of staples during manufacture.

REDMORE

A	B	C	Part #	MOQ	Approximate Pcs/50 lb Keg	Approximate Pcs/lb
Overall Length	Inside Spread	Wire Diameter				
1¼	¼	.148	CP1225K ★	—	4675	94.00
1½	¼	.148	CP1525K ★	—	3750	75.00
1½	5/16	.148	CP1531K ★	—	3750	75.00
1½	½	.148	CP1550K ★	—	3750	75.00
1¾	¼	.148	CP1725K ★	—	3200	64.00
2	¼	.148	CP2025K* ★	450 lbs	2907	58.14
2¾	¾	.187	CP2775S* ★	500 lbs	1285	25.70

*MOQ (Minimum Order Quantity)

★ Made in USA

For 50lb keg packaging, contact customer service for quantities and availability.

GALVANIZED CUT POINT STAPLES • BULK PACK • 50LB KEG



- Pounds per box is approximate and can vary + or – 10% depending on variances in wire weights and tolerances of staples during manufacture.

A	B	C	Part #	MOQ		Approximate Pcs/50 lb Keg	Approximate Pcs/lb
Overall Length	Inside Spread	Wire Diameter					
1½	¼	.148	CG1525K ★ ♡	—		3500	70.00
1½	⅜	.148	CG1538K* ★ ♡	600 lbs		3600	72.00
1¾	⅜	.148	CG1738K* ★ ♡	600 lbs		3125	62.50
2	½	.162	CG2050Q ★ ♡	—		2235	44.70

*MOQ (Minimum Order Quantity)

★ Made in USA

♡ Harsh Environment Product

COPPERCLAD CUT POINT STAPLES • BULK PACK • 50LB KEG



- Due to volatility of copper market, please contact customer service for pricing.
- Pounds per box is approximate and can vary + or – 10% depending on variances in wire weights and tolerances of staples during manufacture.

A	B	C	Part #	MOQ		Approximate Pcs/50 lb Keg	Approximate Pcs/lb
Overall Length	Inside Spread	Wire Diameter					
1½	⅜	.162	CC1538Q ★	—		3075	61.50
1¾	⅜	.144	CC1738I ★	150 lbs		3275	66.00
2	¼	.162	CC2025Q ★	—		2450	49.00
2	½	.162	CC2050Q ★	—		2275	46.00

*MOQ (Minimum Order Quantity)

★ Made in USA

COMMON NAILS SIZE GUIDE

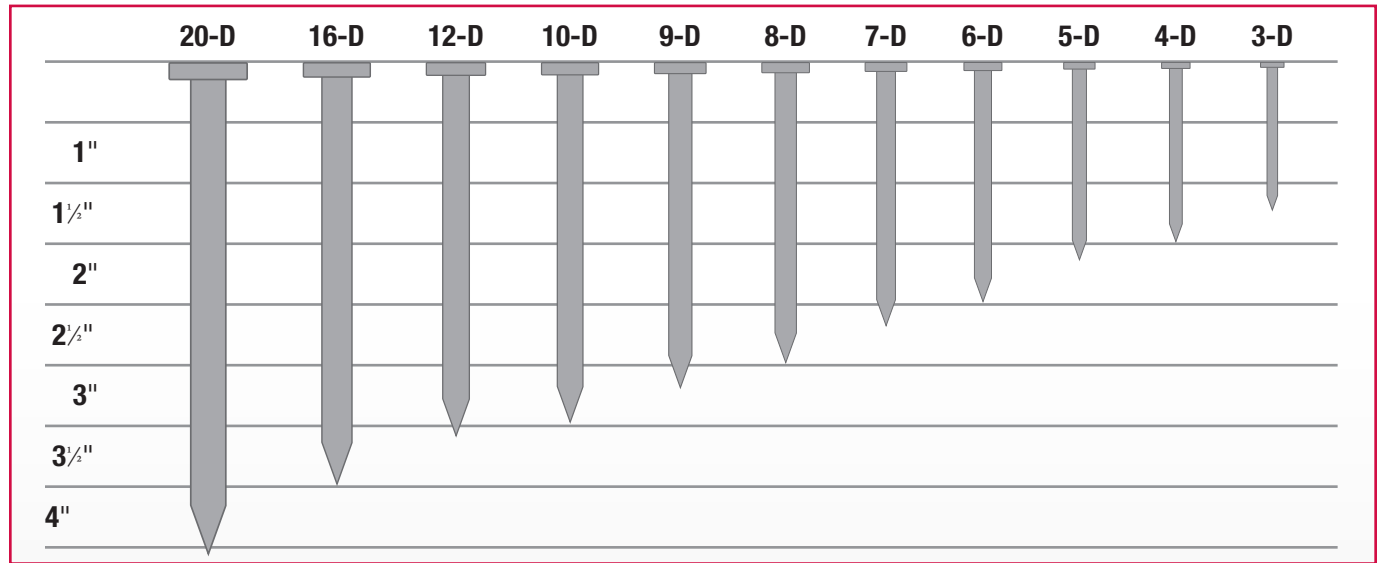

Note: See Wire Guide Reference on page 268.

COPPERCLAD COMMON NAILS • BULK PACK • 50 LB KEG



- Pounds per box is approximate and can vary + or – 10% depending on variances in wire weights and tolerances of staples during manufacture.
- Due to volatility of copper market, please contact customer service for pricing.

Size	Length (Inches)	Diameter (Inches)	Part #	MOQ	Approximate Pcs/50 lb Keg	Approximate Pcs/lb
6-D	2	.114	NC06* ★	100 lbs	7500	150
10-D	3	.144	NC10 ★	—	3450	69
16-D	3½	.162	NC16 ★	—	2350	47

*MOQ (Minimum Order Quantity)

★ Made in USA

GALVANIZED MARKING NAILS



- All marking nails are 2½ x 6 gauge with ½" heads and weigh approximately 2.3 lbs per 100 pieces + or – 10% depending on variances in wire weights and tolerances of nails during manufacture.

Data & Blank Dating					Data Dating			
Description	Part #	MOQ	Pcs/Box	lbs/Box	Description	Part #	MOQ	Approximate Pcs/50 lb Keg
2018 Dating	ND218* ★ ♡	30,000	100	2.2	2018 Dating	ND318* ★ ♡	650 lbs	2350
2019 Dating	ND219 ★ ♡	—	100	2.2	2019 Dating	ND319 ★ ♡	—	2350
2020 Dating	ND220 ★ ♡	—	100	2.2				
Blank Dating	ND1900 ★ ♡	—	100	2.2				

*MOQ (Minimum Order Quantity)

★ Made in USA

♡ Harsh Environment Product

American Steel and Wire Gauge					
Actual Size of Wire	Gauge	Gauge	Diameter	lbs/ft	ft/lb
		000	.3625	.3505	2.853
		00	.3310	.2922	3.422
		0	.3065	.2506	3.991
		1	.2830	.2136	4.681
		2	.2625	.1838	5.441
		3	.2437	.1584	6.313
		4	.2253	.1354	7.386
		5	.2070	.1143	8.750
		6	.1920	.09832	10.17
		7	.1770	.08356	11.97
		8	.1620	.07000	14.29
		9	.1483	.05866	17.05
		10	.1350	.04861	20.57
		11	.1205	.03873	25.82
		12	.1055	.02969	33.69
		13	.0915	.02233	44.78
		14	.0800	.01707	58.58
		15	.0720	.01383	72.32
		16	.0625	.01042	95.98
		17	.0540	.007778	128.6
		18	.0475	.006018	166.2

Fraction	Decimal
1/64	.015625
1/32	.03125
3/64	.046875
1/16	.0625
5/64	.078125
3/32	.09375
7/64	.109375
1/8	.125
9/64	.1450625
5/32	.15625
11/64	.171875
3/16	.1875
13/64	.203125
7/32	.21875
15/64	.234375
1/4	.25
17/64	.265625
9/32	.28125
19/64	.296875
5/16	.3125
21/64	.328125
11/32	.34375
23/64	.359375
3/8	.375
25/64	.390625
13/32	.40625
27/64	.421875
7/16	.4375
29/64	.453125
15/32	.46875
31/64	.484375
1/2	.5
33/64	.515625
17/32	.53125
35/64	.546875
9/16	.5625
37/64	.578125
19/32	.59375
39/64	.609375
5/8	.625
41/64	.640625
21/32	.65625
43/64	.671875
11/16	.6875
45/64	.703125
23/32	.71875
47/64	.734375
3/4	.75
49/64	.765625
25/32	.78125
31/64	.796875
13/16	.8125
53/64	.828125
27/32	.84375
55/64	.859375
7/8	.875
57/64	.890625
29/32	.90625
59/64	.921875
15/16	.9375
61/64	.953125
31/32	.96875
63/64	.984375
1	1

The Wire Gauge Chart shown above is used as a standard by practically all the steel manufacturers in the United States, on recommendation of the Bureau of Standards at Washington, D.C.

Gauges such as Brown & Sharpe and screw gauges do not apply.



MACHINE SCREWS
GROUND SCREWS



SHEET METAL SCREWS



TEX SCREWS



DRYWALL SCREWS
WOOD SCREWS

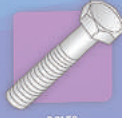

BOLTS
LAG SCREWS



NUTS
WASHERS



ANCHORS



FIXTURE
HANGING HARDWARE

PRODUCT DISPLAYS



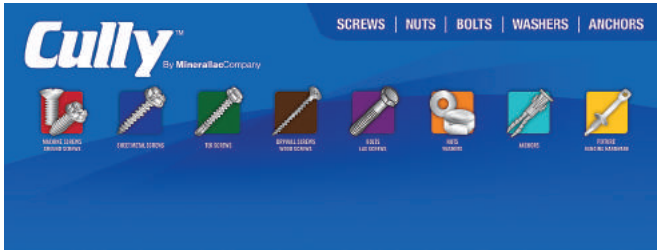

Gravity Feed Jar Rack Display

- Available in three and four foot displays to maximize showroom space.
- Heavy duty display with locking casters.
- Color coded headers.
- Stair stepped shelving to maximize product visibility.
- Wire dividers for product organization and space allocation.
- Magnetic shelf labels featuring product color code and UPC information.

Gravity Feed Jar Rack

Description	Part #	Qty
36" W x 75" H	94353	1
48" W x 75" H	94352	1

Gravity Feed Jar Rack Headers

Description	Part #	Qty
36" Header	00067	1
48" Header	00068	1





Gondola Display

Increase sales with our gravity feed gondola display and custom merchandising Plan-O-Gram program with qualifying order. Together we will design a custom merchandising Plan-O-Gram program to target your specific market needs. Contact a Minerallac Company representative for details.

- Available in three and four foot displays.
- Low maintenance gravity feed display to promote high impulse buying.
- Clean and organized display presentation.
- Suitable for a wall installation or freestanding set-up.

Gondola Display

Description	Part #	Qty
48" W x 54" H, Heavy Duty	94454	1
48" W X 66" H, Heavy Duty	94466	1
48" W x 10" D, Shelf	94410	1
48" W x 12" D, Shelf	94412	1
Caster Base for 48" Gondola	94456	1

Peg Hooks

Description	Part #	Qty
1/8" Gauge x 6" Long	94006	1
1/4" Gauge x 8" Long	94008	1

Gondola Headers

Description	Part #	Qty
48" Header w/ Bracket	00069	1



Displays

Accusharp® Knife Sharpener Display

Part #00037

- Attractive signage attached to a demo unit.
- No charge with qualifying order of 12 sharpeners.



Cully™ Screwdriver Counter Display

Part #37125

- Maximize your POP sales with this great looking counter display.
- See page 136-137 for a full list of parts.



Accusharp® Knife Sharpener Floor Display

Part #00046

- Free standing unit.
- Attention grabbing signage.
- No charge with qualifying order of 36 sharpeners.



Krylon®/Sprayon® Counter Display

Part #37700

- Holds 18 cans of paint, chemicals or caulk.
- Attention grabbing header sign.
- Free with qualifying order of 72 cans/tubes.



Counter Glove Display

Part #67585

- Free with first time order of 24 pairs of work gloves.
- See pages 168-170 for our glove section.



Morse® Reciprocating Saw Blade Wall Mount Display

Part #95328

- No charge with qualifying order over \$300 of any reciprocating blade.



Morse® Hole Saw Wall Mount Display

Part #86553

- No charge with qualifying order.



CrossFire® Display

Part #19119

- No charge counter display with qualifying order.



Shovel Hooks

Part #00042

- Wall mounted peg hooks are designed to hold shovels in smaller spaces.
- Free with qualifying order of 12.

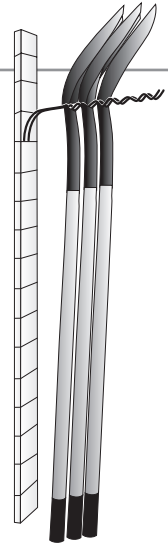

Symbols

3-Piece Knock-Out Seals	175
6-in-1 Economy Screwdriver	124
10 Person First Aid Kit	167
13-in-1 Ratcheting Screwdriver	124
14-in-1 HVAC Screwdriver	124
15-in-1 MEGAPRO Screwdriver, Stainless Steel	122
15-in-1 Shaftlock 2 Screwdriver	125
15-in-1 Tamperproof 2 Screwdriver	124
16-in-1 MEGAPRO Screwdriver	123
25 Person First Aid Kit	167
118° Point	
High Speed Jobber Drills	135
135° Point	
High Speed Jobber Drills	136
Trinado Heavy-Duty Drills	137

A

Accusharp® Knife Sharpener ..	149
Acoustical	
Eye Lags	47
Eye TekS.....	47
Lighting	
Support Assembly	337
Troffer Fastener.....	338
T-Bar	
Box to T-Bar Fastener.....	337
Drop Wire Clip	207
Fasteners.....	340-341
Hanger, Two Piece.....	207
Scissor Clips, Two Piece.....	207
Twist on T-Bar Hanger.....	338
Wedge Anchors	75
Acrylic Enamel Paint	
Krylon Industrial Tough Coat..	101
Adhesive	
Firestop	116-117
Industrial	113
Roof Cement.....	113
Silicon Sealant.....	112
Splice Kits.....	150
All Purpose Rags & Scrubs	115
Scrubs-In-A-Bucket.....	115
All Thread Rod (ATR)	
Threaded Rod.....	94, 256
Size Reference Charts ...	343-344
Anchor Kits	
Concrete Screw	36-37
Double Drywall	78
Expander Anchor	88
EZ Ancor.....	67-69
EZ Toggle	80
Green Plug	84

Rod Hangers.....	93-94
Red Plastic Conical.....	85-86
SnapSkru	73
Toggler Alligator Solid Wall.....	74
Yellow Winged	87
Anchors	
Acoustical Wedge	76
Alligator Solid Wall	
Plastic Toggler	73
Concrete	
Flat Head Phillips	37
Hex Washer Head Slotted	37
Double Drywall	78
Flat Head Split Bolt.....	79
Green Plug	84
Hollow Wall	
Phillips/Slotted	72
Phillips/Slotted with Drive Point	72
Lag Screw Shield	81
Lead, Machine Screw	83
Lead, Sheet Metal or Wood Screw	81
Nail-In	
Zamac "Hammer Drive"	78
Plastic Anchors	
Expander.....	88
Red Conical.....	85-86
Yellow Winged	87
Self-Drilling	
EZ Ancors	
#6 Plastic Lite	69
#6-8 Zinc Alloy.....	68
#8 Plastic.....	69
#8 Zinc Alloy	67
Triple Pack	68
Sleeve Anchor	76
SnapSkru SP Toggler	73
Steel Drop-In.....	82
Strike Set	77
Toggle Bolt	
EZ Toggle	80
Plastic Toggler.....	73
Toggler Snaptoggle	70
with Wings	
Truss Head	
Slotted/Square	71
Truss Head	
Phillips/Slotted	71
Round Head Slotted	71
Toggle Bolt Wings	72
Wall Dog.....	84
Wedge Anchor	75
Stainless Steel	241
Angle Fittings	
Corner Angles.....	273-279
Angle Braces	280
Anti-Short Bushings	155
Auger Bits	

8" Ship	141
17" Ship.....	141
Extensions.....	141
Sharpening File	141

B

Bar Joist Washers	215
Barricade Tape	158
Beam Clamp	
Malleable	202
Spring Steel.....	326
Stainless Steel.....	219
Universal	202
Strut Fittings.....	281-287
Beam Clamp Assemblies	
Cable Support J Hook.....	216
Cable Tie Fastener	172
Conduit	
Conduit & Box Support	332
Spring Steel	
Hammer On ...	230-231, 237
Steel	332
Rod/Wire Hanger	324
Strap Hangers	325
Threaded Rod.....	324
Belleville Washers	67
Bell Hanger Bits, Wood	140
Bell & Thermostat Staples	350
Belts	121
Bits (see Drill Bits & Driver Bits)	
Blister Pack Bits	126-129
Double Ended Power Bits	127
Hex Bolt Driver	128
Hex Power Bits	126-127
Phillips	127
Slotted	127
Square	126
Hex Tek	128
Bits	128
Driver.....	128
Jobber Drills/Split Points.....	129
Spanner	126
Star	129
Socket Pin.....	129
Blow Twine, Polypropylene	153
Bolts	
Anchors.....	67-88
Cap Screws, Hex Head	
Grade 2	51-52
Grade 5.....	53
Silicon Bronze	54
Stainless Steel	230-233
Carriage Bolts.....	50
Eye Bolts with Hex Nuts.....	48
Hex Head Lag Screws.....	49
Stove Bolts	31
U-Bolts	48
Box Support	
Bar	342

Beam	332
Conduit & Box	332
Far Side.....	336
Flange.....	203
Screwless	205
Stud	
Stabilizer.....	205
Mounting Bracket.....	204, 337
Box to Bar	337
Fastener.....	334
T-Bar	337
Brackets	215
Strut Fittings.....	288-293
Bridle Rings	209-210
Cable Support.....	209-210
Stainless.....	258
Bushings	
Anti-Short.....	155
Knock-Out.....	155
Steel Stud	155

C

Cable Clip	
Flexible Conduit/Cable	
Flange	203
Flexible Conduit/Cable Stud...	333
Cable Connectors	154
Cable Protection	
Nail Plates	211
Stud Grommets	155, 210
Cable Support	
Bridle Rings.....	209-210
D-Rings.....	212
J-Hooks	208
Service Entrance	
One-Hole Straps.....	198
Two-Hole Straps.....	199
Staples	350
Ties.....	172-173
Tie Fasteners	172-173
Cable Ties	172-173
Fastener	172
Kits.....	173
Mounting Bases.....	173
Mounting Ties.....	179
Tensioning Tool.....	173
Cap Screws, Hex Head	
Grade 2	51-52
Grade 5	53
Silicon Bronze	54
Stainless Steel.....	230-233
Cap Nuts, Specialty	58
Carbide Drill Bits	
Percussion	139
SDS Rotary/Hammer	139
Straight Shank, Rotary Only...	139
Carbide Grit Hole Saws	145
Carbide-Tipped Masonry Drill Bits	130

Carbon Steel & Hex Shank Taps

Carbon Steel Taps.....	146
Wrenches.....	146
Drill Set.....	146
Carded Bits	126-129
Double Ended Power Bits.....	127
Hex Bolt Driver.....	128
Hex Power Bits.....	126-127
Phillips.....	127
Slotted.....	127
Square.....	126
Hex Tek.....	128
Bits.....	128
Driver.....	128
Jobber Drills/Split Points.....	129
Spanner.....	126
Star.....	129
Socket Pin.....	129

Carriage Bolts.....

50

Carton Sealing Tape.....

157

Caulk

Firestop..... 117

Gun..... 112, 117

Silicone..... 112

Caution Tape.....

158

Ceiling Cover Plate.....

175

Chain

Double Loop Tenso..... 97

Jack..... 97

Stainless..... 257

S-Hooks..... 98

Channel Nuts.....

260-261

Spring Nut..... 260

Short Spring..... 260

No Spring Channel Nut..... 261

Long Spring Nut..... 261

Top Spring Nut..... 261

Cleaners

Contact..... 104

Electronic..... 105

General Purpose..... 108

Glass..... 120

Rags..... 115

Scrubs..... 115

Selection Guide..... 102-103

Closed Clip.....

197

Coarse Thread Screws

Drywall, Phillips..... 44

Common Nails.....

360

Galvanized..... 360

Copperclad..... 360

Size Guide..... 360

Concrete/Masonry Anchors

Acoustical Wedge..... 76

Concrete Screws..... 36-37

Flat Head Split Bolt,
Zinc-Plated Steel..... 79

Lag Screw Shields..... 81

Lead Machine Screw..... 83

Lead Screw..... 81

Nail-In

Light Duty..... 79

Zamac "Hammer" Drive..... 78

Sleeve, Medium Duty..... 76

Steel Drop-In..... 82

Strike Set, Solid Concrete..... 77

Wedge..... 75

Stainless Steel..... 241

Condrive Installation Tool

Kits..... 36

Conduit

Beam Clamp

Assembly..... 203, 320, 327

Clip..... 314, 316

Conduit & Box

Support..... 321-322, 332

Conduit to Conduit, Trapeze... 315

Conduit to Stud..... 334

Conduit Support w/Bracket... 333

Conduit to T-Bar..... 339-341

Flange Mount Assembly..... 331

Flexible (see Flexible Conduit)

Foam Pistons..... 162

Hangers

Spring Steel..... 314

Stainless Steel..... 217

Steel..... 189-190

Hubs..... 66

Measuring Tape..... 161

Multi-Function

Clip Assembly..... 317

Nail Straps..... 200-201

One-Hole Straps..... 191-195

Stainless Steel..... 218

Perforated Strapping..... 98, 214

Reducing Washers &
Bushings..... 180

Roof Jacks, Flashing..... 177

Service Entrance Caps..... 177

Size Reference Charts..... 343-344

Sleepers, Pre-Kuts Plastic..... 177

Strut Clamps..... 263-268

Two-Hole Straps

Plastic..... 197

Stainless Steel..... 218

Z Purlin Assembly..... 329

Contact Cleaner.....

102-104

Copper Tubing Conduit Strut

Clamps..... 264

Corrosion Compatibility.....

343

Corrosion Inhibitors.....

107

Crayons, Lumber

Crossfire Safety

Glasses..... 159-162

Cut Point Staples.....

358-359

Cutting Oil.....

106, 114

D

Damaged Screw

Removal Set..... 147

Degreaser

Contact..... 104

Electronic..... 105

General Purpose..... 108

Selection Guide..... 102-103

Deep Thread

Particle Board..... 41-42

Dial-A-Bit Kit.....

131

Diamond

Point Staples..... 353-357

Displays

Accusharp® Knife Sharpener... 365

Cully™ Screwdriver..... 365

CrossFire®..... 366

Glove..... 365

Gondola Header & Display..... 364

Gravity Feed Jar

Header & Display..... 363

Hole Saw, Morse®..... 366

Krylon®/Sprayon®..... 365

Reciprocating Saw Blade,
Morse®..... 366

Shovel Hooks..... 366

Drill Bits

Bell Hanger..... 140

Carbide

Percussion..... 139

SDS Rotary/Hammer..... 139

Straight Shank Rotary..... 139

Tipped..... 130

Electrician's Power Bits..... 140

Flex Shank (Fish)..... 140

Hex 135° Split Point Set..... 138

Jobber High Speed

118° Point..... 135

135° Point..... 136

Sawtooth..... 142

Special Set, Cobolt &
Titanium..... 138

Speedbor 2000..... 142

Trinado

135° Point Heavy Duty..... 137

Metal Index Set

Heavy Duty..... 137

Wood, Auger

8" Ship..... 141

17" Ship..... 141

Extension &
Sharpening File..... 141

D-Rings.....

212

Driver Bit.....

131

Accessories..... 131

Dial-A-Bit Kit..... 131

Drill Adaptor..... 131

Phillips

Hex Power..... 132

Screwdriver..... 122-125

Pozi Drive..... 130

Slotted

Hex Power..... 133

Screwdriver..... 122-125

Socket Pin

Insert..... 130, 134

Screwdriver..... 122-125

Spanner

Insert..... 130, 134

Screwdriver..... 122-125

Square

Hex Power..... 132

Screwdriver..... 122-125

Star Pin

Insert..... 130, 134

Screwdriver..... 135

Tamperproof Insert..... 142

Tri-Wing..... 138, 142

Drive Stop® Diamond

Point Staples..... 357

Drywall

Anchors..... 78

Hole Saws..... 144-145

Jab Saw..... 147

Screws..... 43-44

Duct Seal Compound.....

114

Duct Tape.....

157

Duplex Jiffy Clip.....

195

Dust Mask.....

165

E

Ear Plugs.....

165

Electronic

Cleaners..... 105

Degreasers..... 105

EMT Conduit Strut Clamps.....

264

Expander Anchors.....

88

Eye Bolts with Hex Nuts.....

48

Eye Lags.....

47

EZ Ancors™.....

67-69

EZ Toggle™ Ancors.....

80

F

Far Side Box Support.....

336

Fender Washers.....

61

Stainless Steel..... 228

Fiberglass

Handled Tools..... 118-119

Fine Thread

Drywall, Phillips..... 43

Finish Cup Washers

Brass..... 64

Stainless Steel..... 229

Fittings.....

269-272

Flat..... 269-272

Angle..... 273-280

Firestop Products

Caulk.....	117
Gaskets.....	116
Lectra-Stop™.....	116
Pillows.....	117
Putty Pad.....	116
Putty Sticks.....	117

First Aid Kits

10 Person.....	167
25 Person.....	167

Fixture Hanging Hardware

Brackets.....	223
Chain.....	97
Hangerbolts.....	95
Lighting Support Assembly ...	337
Plumber's Tape, Perforated Strap.....	98, 214
S-Hooks.....	98
Stud Clip Adaptor.....	214
T-Bar	

Drop Wire Clip.....	207
Hanger, Two-Piece.....	207
Fasteners.....	340-341
Scissor Clip.....	207
Twist-On.....	338

Tie Wire.....	108
---------------	-----

Threaded Rod.....	94, 256
-------------------	---------

Bracket Supports.....	323
Beam Assembly.....	324
Flange Hanger.....	331
Rod Hangers.....	93-94, 325
Hex Rod & Reduced Couplings.....	96

Sammys®.....	89-92
Z Purlin.....	329

Troffer Fastener.....	338
V-Hooks.....	98

Flange

Cable/Conduit Clips.....	319-321
Clamps, Beam.....	328
Clip, Two-Piece.....	203
Hanger.....	331
Multi-Function Clip.....	317

Flat Cut Washers

Zinc-plated.....	59
Brass.....	60
Silicon Bronze.....	60
Stainless Steel.....	226

Flat Fittings

Square Washer.....	269
Square Washer - Notched.....	269
Cross Plates.....	269
Splice Plates.....	270
Swivel Plates.....	271
Corner Plates.....	271-272
Tee Plates.....	272

Flat Head Screws

Machine Brass.....	45
-----------------------	----

Phillips.....	34
Slotted.....	33-34
Square.....	32
Stainless Steel.....	245
Wood, Square.....	39-40

Sheet Metal Square.....	20
Spanner.....	253
Stainless Steel.....	249-254

Flat Head Split Bolt Anchors ...	79
---	----

Flexible Conduit/Cable Clip

Anti-Short Bushings.....	163
Cable Clip.....	316
Cable Ties.....	172-173
Connectors.....	154
Hanger.....	314
Grommets.....	155, 210
Knock-Out Bushings.....	163
Nail Plates.....	211

Straps

One-Hole.....	191-195
Two-Hole.....	196-197
Stud Fastener.....	336
Support	

Bridle Rings.....	209-210
D-Rings.....	212

Flex Shank Drill Bits (Fish Bits)
--

Wood, Self-Feed Screw Point.....	140
-------------------------------------	-----

Foam Conduit Pistons	154
-----------------------------------	-----

Framing Screws	22
-----------------------------	----

Friction Tape	156
----------------------------	-----

G

Galvanic Corrosion	343
---------------------------------	-----

Gaskets, Firestop	116
--------------------------------	-----

Glass Cleaner	108
----------------------------	-----

Gloves

1927® Cold Weather Grain Pigskin.....	168
Frostbreaker® Thermal Latex Gripping.....	169
Grain Leather Drivers.....	168
Kevlar® Lined.....	169
Latex Coated Knit.....	168
Lined Brown Jersey.....	168
Nitrile Palm Coated.....	169

Pro-Grip Full Finger.....	170
Half Finger.....	170
Mechanic's Plus.....	170
Mesh Utility.....	170
Winter Plus.....	170
PVC Dipped.....	169

Split Leather Drivers.....	168
Split Leather Work.....	168
Unlined Brown Jersey.....	168
Deerskin Drivers.....	168

Grain Pigskin Drivers.....	168
Warm Grip Latex Work.....	169

White Canvas.....	169
String Knit.....	169

Grade 2	51-52
----------------------	-------

Grade 5 Bolts.....	51
Nuts.....	57

Grommets, Steel Stud ..	155, 210
--------------------------------	----------

Green Plug Anchors	84
---------------------------------	----

Grounding

Clamps.....	66
Clips.....	65
Drive Stop® Staple.....	357
Hubs.....	66
Pigtails.....	65
Screws.....	65

H

Hacksaw	145
----------------------	-----

Hangerbolts	95
--------------------------	----

Hangerbolt Drivers	95
---------------------------------	----

Hangers	189-190, 217
----------------------	--------------

Beam Clamp.....

Bridle Rings.....	209-210
-------------------	---------

Chain, Jack & Tenso.....	97
--------------------------	----

Conduit.....	189-190, 217
--------------	--------------

Beam Assembly.....	324
--------------------	-----

Hammer On.....	319-320
----------------	---------

Z Purlin.....	328-330
---------------	---------

Eye Bolts.....	48
----------------	----

Eye Lags.....	47
---------------	----

Eye Tek.....	47
--------------	----

Flange.....	247
-------------	-----

Vertical.....	239-240
---------------	---------

J-Hooks.....	208
--------------	-----

Perforated Strap.....	98, 214
-----------------------	---------

Strap Hangers.....	234
--------------------	-----

Threaded Rod.....	94, 256
-------------------	---------

Beam Assembly.....	324
--------------------	-----

Bracket Assembly.....	323
-----------------------	-----

Rod Hangers.....	93-94, 325
------------------	------------

Sammys®.....	89-92
--------------	-------

Vertical Flange.....	331
----------------------	-----

Z Purlin.....	328-330
---------------	---------

Hard Hats	166
------------------------	-----

Charger™ Safety Cap.....	166
--------------------------	-----

Liners.....	166
-------------	-----

Hardware/Accessories	221-223
-----------------------------------	---------

Hex Drill Set	138
----------------------------	-----

Hex Driver Bits	133
------------------------------	-----

Hex Head

Bolts, Cap Screws.....	51-54,
------------------------	--------

Grade 2.....	51-52
--------------	-------

Grade 5.....	53
--------------	----

Silicon Bronze.....	54
---------------------	----

Stainless Steel.....	230-237
----------------------	---------

Lag Screws.....	49, 238
-----------------	---------

Hex Nuts	55-57
-----------------------	-------

Brass.....	56
------------	----

Flange Whiz.....	57
------------------	----

Grade 5.....	57
--------------	----

Nylock.....	57
-------------	----

Stainless Steel.....	224-225
----------------------	---------

Silicon Bronze.....	56
---------------------	----

Hex Power Bits

Phillips.....	132
---------------	-----

Slotted.....	133
--------------	-----

Square.....	132
-------------	-----

Hex Rod Coupling	96
-------------------------------	----

Hex Shank Taps	146
-----------------------------	-----

Hex Washer Head

Sheet Metal Screw.....	17-18
------------------------	-------

Sharp Points.....	21
-------------------	----

Tek Self-Drilling.....	25-26
------------------------	-------

High Speed Jobber Drills

118° Point.....	135
-----------------	-----

135° Point.....	136
-----------------	-----

Hole Saws

Arbors & Pilot Drills.....	143
----------------------------	-----

Carbide Grit.....	145
-------------------	-----

Kits.....	144-145
-----------	---------

Electrician's Hole Saw.....	144
-----------------------------	-----

Maintenance.....	145
------------------	-----

Master Electrician's.....	146
---------------------------	-----

Variable Pitch, Bi-Metal.....	144
-------------------------------	-----

Hollow Wall Anchors	67-74
----------------------------------	-------

Combo Phillips/Slotted.....	72
-----------------------------	----

Drive Point.....	72
------------------	----

Expander.....	88
---------------	----

EZ Ancor®.....	67-69
----------------	-------

Green Plug.....	84
-----------------	----

Red Conical.....	85-86
------------------	-------

SnapSkru™.....	73
----------------	----

Toggle Bolt & Wings.....	71-72
--------------------------	-------

Toggle® Alligator®.....	74
-------------------------	----

Toggle® Plastic.....	73
----------------------	----

Toggle® Snaptoggle®.....	70
--------------------------	----

Wall Dog.....	84
---------------	----

Yellow Winged.....	87
--------------------	----

I

Insulated Metal Staples

Plastic Insulator Cable.....	348
------------------------------	-----

PVC Dipped Cable.....	348
-----------------------	-----

Insulated Plastic Staples

Bell & Thermostat.....	358
------------------------	-----

Non-Metallic Sheathed Cable.....	350
-------------------------------------	-----

Plastic Cable.....	349
--------------------	-----

Service Entrance.....	350
-----------------------	-----

Inverted Marking Paint

Krylon® Industrial Quik-Mark™.....	99
------------------------------------	----

Paint Accessories.....	100
------------------------	-----

Paint Color Selection Guide... 100

J

Jab Saw 147
Jack Chain 97
 Stainless Steel..... 257
J-Hooks..... 208
Jiffy Clip®
 One-Hole Duplex 199
 One-Hole Strap
 Heavy Duty 198
 K-Series..... 195
 Medium Series..... 197
 Min-E® Series 197
 Standard Series 196
 Slotted Duplex..... 199
Jobber Drill 135-136

K

Knife
 Sharpener, Accusharp® 149
 Utility
 Quickblade..... 149
 Titan, Folding 149
Knock-Out Bushings..... 155
Krylon®..... 99-101

L

Lag Screw 49
Lag Screw Shields..... 81
Lead Screw Anchors..... 81
Lead Machine Screw Anchors..... 83
Lectra-Stop™, Firestop Product 116
Lighting
 Support Assembly..... 337
 Troffer Fastener, Acoustical... 338
Line Packages..... 153
Lock Washers
 Octagonal..... 63
 Sealing..... 63
 Split 62
 Silicon Bronze 62
 Stainless Steel 227
 Toothed Lock Washers
 External 63, 227
 Internal 63
Long Spring Nut..... 261
Low Voltage Mounting Bracket..... 212
Lubricants..... 105-106, 112
Lumber Crayons..... 111

M

Machine Screws
 Flat Head

Brass 45
 Phillips 36
 Slotted 33-34
 Square 32
 Stainless Steel 36
Hex Head
 Grade 2 51-52
 Grade 5 53
 Silicon Bronze 54
 Stainless Steel 230-238
Round Head
 Phillips/Slotted Combo ... 27-28
 Square/Slotted 29-30
 Stainless Steel 242-243
Socket Pin 248
Spanner 247
Star Pin 248
Truss Head
 Phillips/Slotted 35
 Square/Slotted 35
Wall Plate 38
Malleable, Beam Clamps 202
Marker Books 178-179
Markers
 Dura-Ink® 15 Black 111
 Lumber Crayon..... 111

MEGAPRO® Screwdrivers

15-in-1..... 122
 16-in-1..... 123
 Quick Change..... 123

Metal Piercing Stud Screws

Metal Stud
 Box Mounting Bracket..... 337
 Box Stabilizer Support.... 203-204
 Box to Bar Fastener 337
 Box to Stud Fastener 334
 Box to Stud Support..... 335
 Bushings 155
 Conduit/Cable Support..... 333
 Conduit to Stud Fastener 336
 Conduit to Stud Support 334
 Far Side Box Support..... 336
 Flexible Conduit/Cable
 Fasteners..... 333

Mule Tape

..... 152

Multi-Function Clip

Assemblies..... 317

Multi-Purpose Closed Clip

..... 197

N

Nail Plates (Safety Plates)

..... 211

Nails

Common Nails Size Guide..... 360
 Copperclad Common 360
 Galvanized Common..... 360
 Galvanized Marking 360
 Galvanized Roofing..... 360

Nail Straps

Combo EMT/Rigid..... 200
 Round Nail Straps..... 201

No Spring Channel Nut

..... 261

Non-Insulated Metal Staples

Cable..... 347
 Service Entrance 347

Non-Metallic Sheathed

Cable Connectors

..... 154

Non-Metallic Sheathed Cable Staples

..... 350

Nuts

..... 55-58
 Cap 58
 Flange Whiz..... 57
 Hex 55
 Brass 56
 Grade 5..... 57
 Nylock..... 57
 Stainless Steel 225
 Silicon Bronze 56
 Stainless Steel 224-225
 Wing 58

O

O.D. Conduit Strut Clamps

..... 265-256

Octagonal, Washers

..... 63

One Piece Strut Clamp

..... 264

One-Hole Duplex

..... 195

One-Hole Strap

..... 191-195
 Heavy Duty Series 192
 K-Series 191
 Medium Series 194
 Min-E® Series..... 194
 Service Entrance 198-199
 Standard Series..... 193

Outlet Retainer

..... 204

P

Paint & Chemicals

..... 99-117
 All Purpose Rags 115
 Chemicals
 Adhesive 112-113
 Industrial E-6000® 113
 Cleaners
 Contact 104
 Electronic..... 105
 General Purpose..... 108
 Glass 108
 Selection Guide..... 102-103
 Cutting Oil, Dark..... 114
 Corrosion Inhibitors 107
 Degreaser
 Contact 104
 Electronic..... 105
 General Purpose..... 108
 Selection Guide..... 102-103

Firestop Products

Caulk 117
 Caulking Gun 117
 Gaskets..... 116
 Lectra-Stop™ 116
 Pillow..... 117
 Putty Pads..... 116
 Putty Sticks..... 117
 Insect Repellents..... 109
 Insulating Varnishes 107
 Lubricants
 Sprayon® 106
 Tri-Flow® 112

Sealants

Duct Seal 114
 Roof Cement..... 113
 Silicone Caulk 112
 Sparyon® Silicone 112
 Stop Gap!™ 113

Lumber Crayons

..... 111

Markers

..... 111

Paint

Accessories..... 100
 Acrylic Enamel 101
 Color Selection Guide..... 100
 Inverted Marking..... 99
 Scrubs-In-A-Bucket..... 115
 Technical Glossary..... 110

Pan Head

Framing Screws
 Sharp Point 22
 Tek..... 22
 Machine Screw, Spanner 48
 Sheet Metal Screw
 Phillip/Slotted Combo 16
 Phillips, Stainless 249
 Spanner 46
 Square 14-15
 Stainless Steel 250
 Tek Sheet Metal Screws

Phillips 24

Square 23

Wall Dog..... 84

Particle Board Screws

..... 41-42

Perforated Strapping

..... 98, 214

Phillips Hex Power Bits

..... 132

Phillips Screw

Drywall

Coarse 44

Fine 43

Machine

Flat Head 34

Round Head Stainless 242

Sharp Point

Framing 22

Wafer Head..... 21

Sheet Metal, Stainless

..... 249

Tek, Self-Drilling

Framing 22

Pan Head 24

Wafer Head, Lath 21

Phillips/Slotted Screws

Machine

Round Head 27-28

Truss Head 35

Truss Head Toggle Bolt 71

Sheet Metal

Hex Washer Head 17

Pan Head 16

Machine Screw w/ Nuts 31

Pick Mattock 118-119

Pillow, Firestop 117

Pipe Wrap 157

Plastic Cable Staples 349

Plumber's Tape

(Perforated Strap) 98, 214

Polyester Tape

Conduit Measuring 153

Pulling 152

Polypropylene

Blow Twine 153

Yellow Pull Rope 152

Post Hole Digger 118-119

Pouches & Bags 120-121

Pre-Kuts Plastic Sleepers 171

Purlin Hangers 328-330

Putty, Firestop

Pad 116

Sticks 117

PVC Electrical Tape 156

Q

Quickblade™, Utility Knife 149

Quick Change 139

Drill Adapter 131

Screwdrivers, MEGAPRO® 123

Quickie Tie-Down 151

R

Rakes 118-119

Receptacle Shim 154

Reciprocating Saw Blades 148

Red Plastic

Conical Anchors 85-86

Reducing Bushings 174

Reducing Washers 174

Repellents, Insect 109

Rod Clips 316-317

Rod Couplings 96

Rod Hangers 325

Rod to Flange Hanger 331

Rod/Wire, Hangers

Beam Assemblies 324

Bracket Support 323

Roof Cement 113

Roof Jacks (Flashings) 171

Rotary Carbide Drill Bits 139

Round

Head Machine Screw

Brass 45

Phillips/Slotted 27-28

Square/Slotted 29-30

Stainless Steel 242-243

w/ Hex Nuts 31

Head Toggle Bolts, Slotted 71

Nail Straps, Combo

EMT/Rigid 201

Washer Head, Sheet Metal

Screw, Square 19

Rubber Tape 156

S

Safety

Barricade & Caution Tape 158

Dust Masks 165

First Aid Kits 167

Glasses

Crossfire® 159-162

Cobra 162

Core 160, 162

ES4 159, 161

ES5 159, 161

Infinity 159-160

KP6 162

RPG 160, 162

Sniper 159-160

HellRaiser™ 164

Nemesis™ 163

RX™ 163

VI™ 163

OTG (Over the Glasses) 164

Smith & Wesson® 164

Gloves 174-176

Hard Hats 172

Hearing Protection 171

Vests 171

Sammy's® Anchoring System

for Concrete

Horizontal Mounting 91

Vertical Mounting 91

for Steel

Horizontal Mounting 90

Vertical Mounting 90

for Wood

Horizontal Mounting 89

Vertical Mounting 89

Sammy® X-Press 92

Saw

Hacksaw 148

Hole Saw 143-145

Jab Saw 147

PVC Cable Saw 148

Reciprocating Saw Blades 148

Sawtooth Self-Feeding Bits 142

Screwdrivers 122-125

6-in-1 Economy 124

13-in-1 Ratcheting 124

14-in-1 HVAC 124

15-in-1 122

15-in-1 Shaftlock 125

15-in-1 Tamperproof 2 124

16-in-1 Tamperproof 123

Spanner 125

Un-Do-It 125

Screws

Acoustical Eye

Lags & Tek's 47

Drywall 43-44

Cap Screws, Hex Head 51-54

Silicon Bronze 54

Stainless Steel 230-233

Extractions

Damaged Screw

Removal Set 147

Screw Extractor & Drill Bit 147

Eyes Lags 47

Framing Sharp & Tek 22

Green Grounding 65

Grounding 65

Hooks 46

Machine

Brass 45

Flat Head 32-34

Stainless Steel 245

Round Head 27-28, 31

Stainless Steel 242-243

Truss Head 35

Socket Pin 248

Spanner 247

Star Pin 248

Lag, Hex Head 49

Particle Board 41-42

Sharp Points

Hex Head 21

Wafer Head 21

Sheet Metal

Flat Head, Square 20

Stainless Steel 251

Hex Washer Head

Phillips/Slotted Combo 17

Slotted 18, 252

Oval, Square Stainless 251

Pan Head 14-24

Phillips/Slotted Combo 17

Phillips, Stainless 249

Square Drive 14-15

Stainless 249-250

Socket Pin 254

Spanner Head 253

Star Pin 254

Tamperproof 253-254

Tek Self-Drilling 23-24

Hex Washer Head 25-26

Stainless Steel 252

Pan Head 23-24

Wafer Head Lath 21

Wall Plate 174

Wood

Flat Head 39-40

Trim Head 41

Scrubs-In-A-Bucket® 115

SDS Rotary/Hammer

Carbide Drill Bits 139

Sealants

Duct Seal 114

E-6000® Industrial Adhesive 113

Sprayon® Clear Silicon 112

Wet Patch Roof Cement 113

White Lightening® Silicon 112

White Lighting® Stop Gap!™ 113

Sealing Washers 63

Service Entrance

Caps 171

Staples 347, 350

Straps

One-Hole 198

Two-Hole 199

Setting Tool 82-83

Steel Drop-In Anchors 82

Sharpener, Knife 149

Sheet Metal Screws

Flat Head, Square 20

Stainless Steel 22

Hex Washer Head

Phillips/Slotted Combo 17

Slotted 18

Oval, Square Stainless 251

Pan Head 14-16

Phillips/Slotted Combo 16

Phillips, Stainless 249

Square 14-15

Round Washer Head, Square 19

S-Hooks 98

Shim Receptacle 154

Short Spring 260

Shovels, Fiberglass

Handled 118-119

Sledge Hammers,

Fiberglass Handled 118-119

Sleeve Anchors,

Concrete/Masonry 76

Slotted

Duplex Jiffy Clip® 195

Hex Power Bits 133

Screwdriver & Insulated 131

Screws, Machine

Brass 45

Flat Head 33-34

Spanner Head 45

Round Head 33-34

Stainless Steel 245

Round Head, Stainless 243

Toggle w/ Wing 71

Wall Plate.....	38
Small-Head Shovel	118-119
Snap-In Knock Out-Seals	175
Socket Pin	
Insert Bits.....	134
Machine Screws.....	248
Sheet Metal Screws.....	253
Spanner	
Drive & Un-Do It Tool.....	125
Machine Screws.....	247
Insert Bits.....	142
Sheet Metal Screws.....	253
“Spark Plugs” Hearing Protection	165
Speedbor 2000™ Wood Bits ...	142
Split Lock Washers	62
Silicon Bronze.....	62
Stainless Steel.....	227
Sprayon®	
Blast ‘Em Wasp & Hornet.....	109
Contact Cleaner	
Selection Guide.....	102-103
Clear Silicone.....	112
Cutting Oil.....	106
Electric Motor Degreaser.....	105
Electrical Cleaner & Lubricating.....	117
Electrical Degreaser, Non-Chlorinated.....	105
Electronic Contact Cleaner.....	104
Environmental	
Contact Cleaner.....	104
and Degreaser.....	105
Flash Free Safety Solvent & Degreaser.....	104-105
General Purpose Cleaner.....	108
Heavy Duty Foaming Degreaser, Neutra-Force®.....	108
Heavy Duty Glass Cleaner.....	108
Heavy Duty Open	
Gear/Wire Rope Lube.....	106
Insect Repellents.....	109
Insulating Varnish.....	107
Long Term Indoor	
Protectant & Lube.....	107
Lubricant, 711® Protector™...	106
Plastics Contact Cleaner.....	104
Rust Breaker™, Penetrant.....	106
Silicone Lube, Premium.....	106
Zinc Rich Cold	
Galvanizing Compound.....	107
Spring Nuts	260
Spring Steel Washers, Belleville	64
Square Drive	
Hex Power Bits.....	132
Machine Screw, Flat Head.....	32
Screwdrivers.....	125
Sheet Metal Screw	
Flat Head.....	20
Stainless Steel.....	251
Oval Head, Stainless.....	251
Pan Head.....	14-15
Stainless Steel.....	250
Round Washer Head.....	19
Tek Self-Drilling Screw.....	23
Wood Screw	
Deep Thread,	
Particle Board.....	41-42
Flat Head.....	39-40
Trim Head.....	41
Square/Slotted Machine Screws	
Round Head.....	29-30
Truss Head.....	35
Staples	
Residential	
Insulated.....	348-350
Bell & Thermostat.....	350
Non-Metallic Sheathed	
Cable.....	350
PVC Dipped Cable.....	348
Plastic Insulator Cable.....	348
Plastic Cable.....	349
Service Entrance	
SER.....	350
SEU.....	350
Non-Insulated	
Cable.....	347
Service Entrance.....	347
Utility	
Cut Point.....	353, 358-359
Copperclad.....	359-360
Galvanized.....	359-360
Pre-Galvanized.....	358
Square Wire Barbed.....	353
Diamond Point.....	353-357
Bright Wire.....	354-355
Copperclad.....	359-360
Drive Stop®.....	357
Electo-Zinc.....	357
Flat Top.....	357
Serrated.....	356
Galvanized.....	356
Double Barbed.....	356
Serrated.....	357
Star Pin	
Insert Bits.....	134
Machine Screws.....	248
Sheet Metal Screws.....	254
Steel Drop-In Anchors	82
Steel Stud	
Box Mounting Brackets..	204, 337
Box Stabilizer Support.....	321
Box to Bar Fastener.....	337
Box to Stud Fastener.....	334
Box to Stud Support.....	335
Bushings.....	155
Conduit/Cable Support.....	333
Conduit to Stud Fastener.....	336
Conduit to Stud Support.....	334

Far Side Box Support.....	336
Flexible Conduit/Cable	
Fasteners.....	333
Step Drills, 2-Flute Split Tip	143
Stove Bolts	
Slotted/Phillips	
with Hex Nuts.....	31
Stainless Steel w/ Nut.....	246
Straight Shank Carbide Drill Bits	139
Strap Hangers	325
Strapping Tape	157
Strike Set Anchors, Concrete ...	77
Strut Clamps	
Rigid Conduit.....	263
Universal Conduit Strut.....	263
EMT Conduit Strut Clamps.....	264
One Piece Strut Clamp with Saddle.....	264
Copper Tubing Conduit.....	263
O.D. Conduit Strut Clamps.....	265-266
Tubing Cushion.....	267
Pipe Cushion.....	268
Clutch Clamps.....	268
Strut Fittings	
Channel Nuts.....	260-261
Swivels.....	262
Strut Clamps.....	263-268
Flat Fittings.....	269-272
Angle Fittings.....	273-280
Beam Clamps.....	281-287
Brackets.....	288-293
End Caps.....	294
Electrical.....	295-297
Post Bases.....	298-300
Rollers.....	294
U-Fittings.....	303-306
Wing Fittings.....	306-309
Z-Fittings.....	310-312
Stud Clip Adapter	214
Suspenders	120
Swivels	262
Female.....	262
Male.....	262
Female-Female.....	262
Male-Female.....	262
Square Washer	269
Notched.....	269

T

Tamperproof	
16-in-1 Screwdriver.....	123
15-in-1 Screwdriver.....	124
29-in-1 Driver Kit.....	130
Driver Bits.....	130
Insert Bits.....	134
Machine Screws.....	247-248
Sheet Metal Screws.....	253-254

Tape	
Barricade & Caution	
Caution-Caution-Caution....	158
Caution High Voltage.....	158
Gas Line Below.....	158
Black PVC Electrical.....	156
Carton Sealing.....	157
Color-Coded PVC Electrical....	156
Conduit Measuring.....	153
Duct.....	157
Friction.....	156
Mule/Pulling.....	152
Plumbers Perforated	
Strap.....	98, 214
Pipe Wrap.....	157
Rubber.....	156
Strapping.....	157
Underground	
Burial.....	158
Detectable.....	158
Tape Measure	151
T-Bar	
Box Hanger Assembly.....	337
Drop Wire Clip.....	207
Fasteners.....	340-341
Flange Clip.....	203
Hanger, Two-Piece.....	207
Lighting Support	
Assembly.....	337
Scissor Clip.....	207
Twist-On Hanger.....	338
Tek Self-Drilling Screws	
Framing.....	22
Hex Washer Head.....	25-26
Pan Head Tek.....	23-24
Stainless Steel.....	255
Threaded Rod	94, 256
Bracket Support.....	323
Coupling.....	96
Hangers.....	325
to Beam Assembly.....	324
to Vertical Flange Assembly....	331
to Z Purlin Assembly.....	329
Tie Wire	96
Toggle Bolts	
EZ Toggle™ Ancors.....	80
Truss Head.....	71
Round Head.....	71
Wings.....	72
Toggle®	
Alligator® Wall Anchors.....	74
Plastic Toggle.....	73
SnapSkru™ Anchor.....	73
Snaptoggle® Toggle Bolt.....	70
Tool Bags & Accessories	120-121
Tool Kits	
Carbon Steel Taps.....	146
Hex Shank Taps.....	146
Hole Saws	

Electrician's Hole Saw Kit.....	144
Maintenance Kit.....	145
Master Electrician's Kit.....	145
Screw Extractors.....	147
Tamperproof.....	130
Condrive Installation.....	36
Urseal Splice Kits.....	150
Tools	
Anchor Setting.....	82-83
All Purpose Bar	
w/Tamper.....	118-119
Bags & Accessories.....	120-121
Blow Twine.....	153
Cable Management.....	162-163
Caulk Gun.....	124
Condrive Installation.....	87
Conduit Measuring Tape.....	153
Drill Bits . 130, 138-143, 126-129	
Driver Bits.....	130-133
Dust Masks.....	165
Ear Plugs.....	165
Firestop Caulking Gun.....	117
Foam Conduit Pistons.....	154
Gloves.....	168-170
Hangerbolt Driver.....	95
Hard Hats.....	166
Hole Saws.....	143-145
Knives & Accessories.....	149
Line Packages.....	153
Marking Wand.....	100
Picking Mattock.....	118-119
Post Hole Digger.....	118-119
Pull Rope.....	152
Pulling Tape.....	152
Rakes.....	118-119
Safety Glasses.....	159-164
Safety Vest.....	165
Sammys® Nut Driver.....	89-91
Sammys® Universal X-Press..	105
Saws.....	155-156
Screwdrivers.....	122-125
Shovels.....	118-119
Sledge Hammer.....	118-119
Splice Kits.....	150
Tape.....	164-166
Tape Measure.....	151
Tie Down Straps.....	151
Utility Probe.....	118-119
Toothed Lock Washers	
External.....	63
Internal.....	63
Top Spring Nut	261
Tri-Flow Lubricants	
with PTFE	112
Trim Head Wood Screws	41
Trinado Heavy-Duty Drills	137
Truss Head Machine Screws	
Phillips/Slotted.....	35
Square/Slotted.....	35
Truss Head SMS,	
Square Screws	19
Twist on T-Bar Hanger	338
Two-Hole Metal Conduit Strap	
Heavy-Duty.....	197
Metal.....	196-197
Plastic.....	197
Service Entrance.....	199
67	

U

U-Bolts	48
Underground	
Burial Tape.....	158
Detectable Tape.....	158
Grounding Clamps.....	66
Splice Kits.....	150
Universal Clamps	
Beam.....	202
Urseal Splice Kits	150
Utility Knives	149
Utility Probe	
Fiberglass Handled.....	119-120

V

Variable Pitch Hole Saws	144
V-Hooks	98
Voice/Data & Low Voltage	
Cable Protection	
Nail Plates.....	211
Cable Support	
Bridle Rings.....	209-210
D-Rings.....	212
J-Hooks.....	208
Low Voltage	
Mounting Bracket.....	212
Metal Stud Grommet.....	210
Wing Nut Washer.....	213

W

Wafer Head Screws	
Tek, Lath.....	28
Sharp Point.....	26
Wall Plate	
Insulating Gasket.....	174
Mounting Bracket.....	212
Screws.....	38
Washers	
Belleville	
Spring Steel.....	64
Stainless Steel.....	229
Fender.....	61
Stainless Steel.....	228
Finish Cup	
Brass.....	64
Stainless Steel.....	229
Flat Cut.....	59-60

SAE Flat Cut.....	59
Brass.....	60
Silicon Bronze.....	60
Stainless Steel.....	226
Octagonal.....	63
Sealing.....	63
Split Lock Washers.....	62
Silicon Bronze.....	62
Stainless Steel.....	227
Toothed Lock Washers.....	63
Wedge Anchors	75-76
Stainless Steel.....	241
Wet Patch Roof Cement	113
White Lighting®	
Silicone Sealant	112
White Lightning® Stop Gap!™ ..	113
Wing Nut	58
Wing Nut Washer	213
Wire & Cable	
Marker Books	176-177
Wood Drill Bits	
Auger	
8" Ship.....	141
17" Ship.....	141
Bit Extensions.....	141
Sharpening File.....	141
Bell Hanger.....	140
Self-Feed Screw Point	
Electrician's Power.....	140
Flex Shank Drill (Fish Bits)....	140
Sawtooth Self-Feeding.....	142
Sharpening File.....	141
Speedbor 2000™ Wood.....	142
Wood Hole Saws	143-145
Wood Screws	
Deep Thread	
Particle Board.....	41-42
Flat Head.....	39-40
Trim Head.....	41

Y

Yellow Polypropylene Rope	152
Yellow Winged Anchors	87

Z

Zamac Nail-In Anchors	78
Z Purlin	
Flange Hanger.....	330
Hanger.....	328
Assemblies.....	329-330

Numerical Index

0

0	189
OB	189
OR	204
OS	217
OSB	217
00037	365
00042	366
00046	365
00067	363
00068	363
00069	364
09382	141

1

1	189
1B	189
1S	217
1SB	217
10	189
10030	111
102	193
102E	193
103	193
103E	193
10406J	14
10408J	14
10410J	14
10412J	14
105	193
105E	193
105SC	192
10604J	14
10606J	14
10606TPJ	253
10608J	14
10608TPJ	253
10610J	14
10610TPJ	253
10612J	14
10612TPJ	253
10616J	14
10616TPJ	253
10620J	14
10620TPJ	253
10624J	14
10624TPJ	253
10628J	14
10632J	14
10632TPJ	253
10707-6	22
10707J	22
10708-6	22
10708J	22
10806J	14
10806TPJ	253
10808J	14
10808TPJ	253
10808XPJ	254
10810J	14
10812-6	14
10812J	14
10812SPJ	254
10812TPJ	253
10812XPJ	254
10816-6	14
10816J	14
10816SPJ	254
10816TPJ	253
10816XPJ	254
10820-6	14
10820J	14
10820TPJ	253
10820XPJ	254
10824-6	14
10824J	14
10824TPJ	253
10828J	14
10832J	14
10832TPJ	253

10840J	14
10848J	14
10B	189
110	193
11008-6	14
11008J	14
11008SPJ	254
11008TPJ	253
11008XPJ	254
11010J	14
11010TPJ	253
11012-6	14
11012J	14
11012SPJ	254
11012TPJ	253
11012XPJ	254
11016-6	14
11016J	14
11016SPJ	254
11016TPJ	253
11016XPJ	254
11020-6	14
11020J	14
11020TPJ	253
11020XPJ	254
11024-6	14
11024J	14
11024TPJ	253
11024XPJ	254
11028J	14
11032-6	14
11032J	14
11032TPJ	253
11040J	14
11048J	14
1105	197
110E	193
11208J	14
11208TPJ	253
11210J	14
11212J	14
11212TPJ	253
11216J	14
11216TPJ	253
11220J	14
11220TPJ	253
11224J	14
11224TPJ	253
11228J	14
11232J	14
11232TPJ	253
11240J	14
11248J	14
11408J	15
11408TPJ	253
11410J	15
11412J	15
11412TPJ	253
11416J	15
11416TPJ	253
11420J	15
11420TPJ	253
11424J	15
11428J	15
11432J	15
11440J	15
11448J	15
115	193
115E	193
115SC	192
120	193
121	193, 198
12406J	39
12408J	39
12412J	39
12416J	39
125	193, 198
125E	193
12606J	20
12606TPJ	253
12608J	20, 39
12608TPJ	253

12610J	20, 39
12610TPJ	253
12612J	20
12612TPJ	253
12616J	20, 39
12616TPJ	253
12620J	39
12620TPJ	253
12621J	20
12624J	39
12624TPJ	253
12625J	20
12628J	39
12632J	39
12632TPJ	253
12806TPJ	253
12808J	20
12808J	39
12808TPJ	253
12810J	20, 39
12812J	20, 39
12812TPJ	253
12812XPJ	254
12816J	20, 39
12816TPJ	253
12816XPJ	254
12820J	39
12820TPJ	253
12820XPJ	254
12821J	20
12824J	39
12824TPJ	253
12825J	20
12828J	39
12832J	39
12832TPJ	253
12833J	20
12840J	39
12848J	39
12856J	39
12864J	39
130	193, 198
13008J	20, 39
13008TPJ	253
13010TPJ	253
13012J	20, 39
13012TPJ	253
13012XPJ	254
13016J	20, 39
13016TPJ	253
13016XPJ	254
13020J	39
13020TPJ	253
13020XPJ	254
13021	20
13021J	20
13024J	39
13024TPJ	253
13025J	20
13028J	39
13032J	39
13032TPJ	253
13033J	20
13036J	39
13040J	39
13048J	39
13056J	39
13064J	39
13208TPJ	253
13212J	20, 40
13212TPJ	253
13216J	20, 40
13216TPJ	253
13220J	40
13220TPJ	253
13221J	20
13224J	40
13224TPJ	253
13225J	20
13232J	40
13232TPJ	253

13240J	40
13248J	40
13256J	40
13264J	40
13408TPJ	253
13412J	40
13412TPJ	253
13416J	40
13416TPJ	253
13420J	40
13420TPJ	253
13424J	40
13432J	40
13440J	40
13456J	40
13464J	40
135	193
13616J	42
13624J	42
13632J	42
13716J	41
137161lb	41
137261lb	41
13726J	41
137361lb	41
13736J	41
137481lb	41
13748J	41
13812J	42
13816J	42
13820J	42
13822J	41
13824J	42
13826J	42
13828J	42
13830J	41
13832J	42
13834J	41
13836J	42
13838J	41
13840J	43
13842J	41
13848J	42
13850J	41
140	193, 198
14016J	42
14020J	42
14022J	41
14024J	42
14026J	41
14028J	42
14030J	41
14032J	42
14036J	42
14038J	41
14040J	42
14048J	42
14300	114
14305	114
145	193, 198
14608TPJ	253
14612TPJ	253
14616TPJ	253
14620TPJ	253
14624TPJ	253
14808J	19
14808TPJ	253
14809-6	21
14809J	21
14810J	19
14811-6	21
14811J	21
14812-6	19
14812J	19
14812TPJ	253
14813-6	21
14813J	21
14816-6	19
14816J	19
14816TPJ	253

14817-6	21
14817J	21
14820-6	19
14820J	19
14820TPJ	253
14821-6	21
14821J	21
14824J	19
14824TPJ	253
14828J	19
14832J	19
14840J	19
14849J	19
14WNNW	213
150	193, 198
15008-6	19
15008J	19
15008TPJ	253
15010TPJ	253
15012-6	19
15012J	19
15012TPJ	253
15016-6	19
15016J	19
15016TPJ	253
15020-6	19
15020J	19
15020TPJ	253
15024-6	19
15024J	19
15024TPJ	253
15032-6	19
15032J	19
15049J	19
15212J	19
15216J	19
155	193, 198
160	193, 198
165	193
170	193
18609J	16
18613J	16
18617J	16
18621J	16
18625J	16
18809J	16
18813-6	16
18813J	16
18817-6	16
18817J	16
18821-6	16
18821J	16
18825J	16
18833J	16
19009-6	16
19009J	16
19013-6	16
19013J	16
19017-6	16
19017J	16
19021-6	16
19021J	16
19025-6	16
19025J	16
19033-6	16
19033J	16
19041J	16
19049J	16
19100	159
19101	159
19102	159
19103	159
19104	160
19105	159
19106	159
19107	160
19110	162
19115	162
19116	160
19119	366
19120	162
19121	160

Numerical Index

19125.....	159	20524TPJ.....	247	22208.....	172	22632TPJ.....	247	25524.....	213
19126.....	159	20532J.....	32	22210.....	172	22704SPJ.....	248	25524J.....	31
19127.....	159	20532TPJ.....	247	22212.....	172	22706SPJ.....	248	25524SSJ.....	213
19128.....	161	20606SPJ.....	248	22214.....	172	22708J.....	29	25524SSJ.....	246
19130.....	162	20606TPJ.....	247	22216.....	172	22708SPJ.....	248	25532J.....	31
19131.....	162	20606XPJ.....	248	22218.....	172	22708TPJ.....	247	25540J.....	31
19132.....	162	20608J.....	32	22220.....	172	22710TPJ.....	247	25548J.....	31
19134.....	161	20608SPJ.....	248	22222.....	172	22712J.....	29	25606TPJ.....	247
19135.....	159	20608TPJ.....	247	22224.....	172	22712SPJ.....	248	25608TPJ.....	247
19136.....	159	20608XPJ.....	248	22226.....	172	22712TPJ.....	247	25612TPJ.....	247
19137.....	159	20612J.....	32	22228.....	172	22716J.....	29	25616TPJ.....	247
19138.....	161	20612SPJ.....	248	22230.....	172	22716SPJ.....	248	25620TPJ.....	247
19209J.....	16	20612TPJ.....	247	22240.....	173	22716TPJ.....	247	25624TPJ.....	247
19213J.....	16	20612XPJ.....	248	22244.....	173	22720TPJ.....	247	25716J.....	31
19217J.....	16	20616J.....	32	22254.....	173	22724J.....	29	25720J.....	31
19221J.....	16	20616SPJ.....	248	22256.....	173	22724SPJ.....	248	25724J.....	31
19225J.....	16	20616TPJ.....	247	22258.....	173	22724TPJ.....	247	25732J.....	31
19233J.....	16	20616XPJ.....	248	22260.....	173	22732J.....	29	25808TPJ.....	247
19241J.....	16	20620J.....	32	22262.....	173	22732TPJ.....	247	25812TPJ.....	247
19249J.....	16	20620TPJ.....	247	22264.....	173	22740J.....	29	25816TPJ.....	247
19413J.....	16	20624J.....	32	22280.....	172	22748J.....	29	25820TPJ.....	247
19417J.....	16	20624TPJ.....	247	22282.....	172	228.....	196, 199	25824TPJ.....	247
19421J.....	16	20632J.....	32	22284.....	172	22804SPJ.....	248	260.....	196, 199
19425J.....	16	20632TPJ.....	247	22286.....	172	22806SPJ.....	248	26008TPJ.....	247
19433J.....	16	20706SPJ.....	248	22290.....	173	22808J.....	30	26010TPJ.....	247
19602.....	165	20708J.....	32	22292.....	173	22808SPJ.....	248	26012TPJ.....	247
19604.....	165	20708SPJ.....	248	22294.....	173	22808TPJ.....	247	26016TPJ.....	247
19608.....	165	20708TPJ.....	247	22296.....	173	22812J.....	30	26020TPJ.....	247
19610.....	165	20708XPJ.....	248	22298.....	173	22812SPJ.....	248	26024TPJ.....	247
19612.....	165	20710TPJ.....	247	223.....	199	22812TPJ.....	247	26208TPJ.....	247
19804.....	163	20712J.....	32	22329.....	166	22816J.....	30	26212TPJ.....	247
19805.....	163	20712SPJ.....	248	22337.....	166	22816SPJ.....	248	26216TPJ.....	247
19806.....	163	20712TPJ.....	247	225.....	196, 199	22816TPJ.....	247	265.....	196
19807.....	163	20712XPJ.....	248	22504J.....	29	22820J.....	30	26606J.....	23
19808.....	163	20716J.....	32	22504SPJ.....	248	22820SPJ.....	248	26808-6.....	23
19809.....	163	20716SPJ.....	248	22504XPJ.....	248	22824J.....	30	26808J.....	23
19810.....	163	20716TPJ.....	247	22506J.....	29	22824SPJ.....	248	26809-6.....	26
19811.....	163	20720J.....	32	22506SPJ.....	248	22832J.....	30	26809J.....	26
19812.....	163	20720TPJ.....	247	22506TPJ.....	247	22832SPJ.....	248	26810J.....	23
19814.....	163	20724J.....	32	22506XPJ.....	248	230.....	196, 199	26811-6.....	26
19831.....	163	20724SPJ.....	248	22508J.....	29	23006J.....	30	26811J.....	26
19832.....	163	20724TPJ.....	247	22508SPJ.....	248	23008J.....	30	26812-6.....	23
19840.....	163	20732J.....	32	22508TPJ.....	247	23012J.....	30	26812J.....	23
19843.....	163	20732TPJ.....	247	22508XPJ.....	248	23016J.....	30	26813-6.....	26
19844.....	163	20740J.....	32	22512J.....	29	23020J.....	30	26813J.....	23
19850.....	164	20748J.....	32	22512SPJ.....	248	23024J.....	30	26816-6.....	26
19852.....	164	20808J.....	32	22512TPJ.....	247	23032J.....	30	26816J.....	23
19860.....	164	20808SPJ.....	248	22512XPJ.....	248	23040J.....	30	26817-6.....	26
19862.....	164	20808TPJ.....	247	22516J.....	29	230SS.....	196	26817J.....	26
19870.....	164	20812J.....	32	22516SPJ.....	248	230SS.....	218	26820J.....	23
19872.....	164	20812SPJ.....	248	22516TPJ.....	247	23298.....	167	26821-6.....	26
19874.....	164	20812TPJ.....	247	22516XPJ.....	248	23300.....	167	26821J.....	26
19880.....	163	20816J.....	32	22520J.....	29	240.....	196, 199	270.....	196
		20816SPJ.....	248	22520TPJ.....	247	2403.....	199	27008-6.....	23
		20816TPJ.....	247	22524J.....	29	240SS.....	196	27008J.....	23
		20820J.....	32	22524TPJ.....	247	240SS.....	218	27010J.....	23
		20824SPJ.....	248	22532J.....	29	24433J.....	35	27012-6.....	23
		21/2.....	189	22532TPJ.....	247	24449J.....	35	27012J.....	23
		21/2S.....	217	22604XPJ.....	248	24465J.....	35	27016-6.....	23
		21/2SB.....	217	22606J.....	29	245.....	196, 199	27016J.....	23
		21008J.....	32	22606SPJ.....	248	245SS.....	196	27020-6.....	23
		21008SPJ.....	248	22606TPJ.....	247	245SS.....	218	27020J.....	23
		21012J.....	32	22606XPJ.....	248	24608J.....	35	27024-6.....	23
		21012SPJ.....	248	22608J.....	29	24733J.....	35	27024J.....	23
		21016J.....	32	22608SPJ.....	248	24749J.....	35	27032-6.....	23
		21016SPJ.....	248	22608TPJ.....	247	24765J.....	35	27032J.....	23
		21020J.....	32	22608XPJ.....	248	250.....	196, 199	27212J.....	23
		21020SP.....	248	22610J.....	29	25049J.....	35	27216J.....	23
		21020SPJ.....	248	22612J.....	29	25065J.....	35	27220J.....	23
		21024J.....	32	22612SPJ.....	248	250SS.....	196	275.....	196
		21024SPJ.....	248	22612TPJ.....	247	250SS.....	218	280.....	196
		21032J.....	32	22612XPJ.....	248	255.....	196, 199	285.....	196
		21032SPJ.....	248	22616J.....	29	25508J.....	31	290.....	196
		21040J.....	32	22616SPJ.....	248	25512J.....	31	292.....	196
		21048J.....	32	22616TPJ.....	247	25516.....	213	294.....	196
		212.....	199	22616XPJ.....	248	25516J.....	31	29430.....	166
		2203.....	199	22620J.....	29	25516SSJ.....	213	29432.....	166
		221.....	199	22620TPJ.....	247	25516SSJ.....	246	29434.....	166
		22200.....	172	22624J.....	29	25520.....	213	29436.....	166
		22202.....	172	22624SPJ.....	248	25520J.....	31	29438.....	166
		22204.....	172	22624TPJ.....	247	25520SSJ.....	213	29440.....	166
		22206.....	172	22632J.....	29	25520SSJ.....	246	29442.....	166

2

2.....	189
2 1/2.....	189
2 1/2B.....	189
2B.....	189
2S.....	217
2SB.....	217
2SC4.....	203
20504J.....	32
20506SPJ.....	248
20506TPJ.....	247
20506XPJ.....	248
20508J.....	32
20508SPJ.....	248
20508TPJ.....	247
20508XPJ.....	248
20512J.....	32
20512SPJ.....	248
20512TPJ.....	247
20512XPJ.....	248
20516J.....	32
20516SPJ.....	248
20516TPJ.....	247
20516XPJ.....	248
20520J.....	32
20520TPJ.....	247
20524J.....	32

Numerical Index

29444..... 166

3

3..... 189
 3B..... 189
 3S..... 217
 3SB..... 217
 300..... 195
 30002..... 125
 30003..... 125
 30006TP..... 125
 30008TP..... 125
 30010TP..... 125
 30012TP..... 125
 30014TP..... 125
 300A..... 195
 300E..... 195
 300SC..... 195
 301..... 195
 301SC..... 195
 305..... 195
 31000..... 125
 31106..... 130, 134
 31106D..... 126
 31108..... 130, 134
 31108D..... 126
 31110..... 130, 134
 31112..... 134
 31114..... 134
 31206..... 125
 31210..... 125
 31214..... 125
 32065..... 165
 32066..... 165
 32067..... 165
 32068..... 165
 33304..... 137
 33305..... 137
 33306..... 137
 33307..... 137
 33308..... 137
 33309..... 137
 33310..... 137
 33311..... 137
 33312..... 137
 33313..... 137
 33314..... 137
 33315..... 137
 33316..... 137
 33317..... 137
 33318..... 137
 33319..... 137
 33320..... 137
 33321..... 137
 33322..... 137
 33323..... 137
 33324..... 137
 33325..... 137
 33326..... 137
 33333..... 137
 33335..... 137
 33336..... 137
 33400..... 174
 33402..... 174
 33404..... 174
 33406..... 174
 33408..... 174
 33410..... 174
 33412..... 174
 33414..... 174
 33416..... 174
 33418..... 174
 33420..... 174
 33422..... 174
 33424..... 174
 33426..... 174
 33428..... 174
 33430..... 174
 33432..... 174
 33434..... 174
 33436..... 174

33438..... 174
 33439..... 174
 33440..... 174
 33441..... 174
 33442..... 174
 33443..... 174
 33444..... 174
 33446..... 174
 33448..... 174
 33450..... 174
 33452..... 174
 33454..... 174
 33456..... 174
 34001..... 125
 34002..... 125
 34003..... 125
 35001..... 125
 35002..... 125
 35003..... 125
 37009..... 130
 37011..... 123
 37014..... 124
 37016..... 124
 37020..... 124
 37021..... 124
 37022..... 124
 37023..... 125
 37125..... 365
 37150..... 123
 37160..... 118, 119
 37161..... 118, 119
 37162..... 118, 119
 37163..... 118, 119
 37164..... 118, 119
 37165..... 118, 119
 37166..... 118, 119
 37167..... 118, 119
 37200..... 122
 37204..... 151
 37205..... 151
 37206..... 151
 37207..... 151
 37208..... 151
 37209..... 151
 37216..... 151
 37218..... 151
 37250..... 118, 119
 37251..... 118, 119
 37253..... 118, 119
 37256..... 118, 119
 37257..... 118, 119
 37259..... 118, 119
 37262..... 118, 119
 37263..... 118, 119
 37265..... 118, 119
 37267..... 118, 119
 37269..... 118, 119
 37271..... 118, 119
 37273..... 118, 119
 37275..... 118, 119
 37277..... 118, 119
 37279..... 118, 119
 37285..... 122
 37285..... 258
 37400..... 149
 37400C..... 149
 37440..... 115
 37450..... 147
 37455..... 99, 100
 37456..... 100
 37457..... 100
 37458..... 100
 37459..... 99, 100
 37460..... 99, 100
 37461..... 99, 100
 37462..... 99, 100
 37463..... 99, 100
 37465..... 99, 100
 37466..... 99, 100
 37467..... 99, 100
 37468..... 99, 100
 37469..... 99, 100

37470..... 99, 100
 37471..... 99, 100
 37472..... 99, 100
 37473..... 101
 37474..... 101
 37475..... 101
 37476..... 101
 37477..... 101
 37478..... 101
 37479..... 101
 37480..... 101
 37481..... 101
 37482..... 99, 100
 37485..... 101
 37486..... 101
 37487..... 101
 37488..... 101
 37489..... 101
 37490..... 101
 37491..... 101
 37492..... 101
 37495..... 108
 37497..... 103, 105
 37498..... 103, 104, 105
 37499..... 103, 105
 37501..... 102, 103, 105
 37502..... 103, 105
 37504..... 102, 104
 37505..... 102, 104
 37506..... 104
 37508..... 106
 37509..... 106
 37510..... 106
 37511..... 106
 37513..... 106
 37514..... 112
 37515..... 112
 37516..... 112
 37518..... 107
 37520..... 107
 37521..... 107
 37522..... 109
 37523..... 109
 37524..... 108
 37525..... 108
 37528..... 107
 37529..... 107
 37530..... 112
 37531..... 112
 37580..... 115
 37582..... 115
 37584..... 115
 37586..... 115
 37587..... 115
 37588..... 115
 37590..... 115
 37591..... 115
 37647..... 99, 100
 37651..... 105
 37655..... 99, 100
 37659..... 99
 37669..... 99
 37676..... 99
 37680..... 102, 104
 37681..... 99, 100
 37692..... 99
 37693..... 99
 37700..... 365
 37725..... 109
 37975..... 149
 38001..... 132
 38002..... 132
 38003..... 132
 38101..... 131, 132
 38101D..... 126
 38102..... 132
 38102D..... 126
 38103..... 132
 38103D..... 126
 38104..... 132
 38104D..... 126
 38106..... 132

38200..... 132
 38201..... 132
 38201-5..... 132
 38201D..... 126
 38202..... 132
 38202-5..... 132
 38202D..... 126
 38203..... 132
 38203-5..... 132
 38203D..... 126
 38204..... 132
 38204D..... 126
 38206..... 132
 38206D..... 126
 38210..... 132
 38212..... 132
 38215..... 131
 38215D..... 127
 38220..... 132
 38222..... 131
 38301..... 132
 38301-5..... 132
 38301D..... 126
 38302..... 132
 38302-5..... 132
 38302D..... 126
 38303..... 132
 38303D..... 126
 38304..... 132
 38304D..... 126
 38306..... 132
 38306D..... 126
 38308..... 132
 38401..... 132
 38401D..... 127
 38402..... 132
 38402D..... 127
 38403..... 132
 38404..... 132
 38406..... 132
 38406D..... 127
 38500..... 132
 38501..... 132
 38501-5..... 132
 38501D..... 127
 38502..... 132
 38502-5..... 132
 38502D..... 127
 38503..... 132
 38503-5..... 132
 38503D..... 127
 38504..... 132
 38504D..... 127
 38506..... 132
 38506D..... 127
 38520..... 132
 38561..... 133
 38561D..... 133
 38562..... 133
 38562D..... 127
 38563..... 133
 38563D..... 127
 38564..... 133
 38601..... 132
 38601D..... 127
 38602..... 132
 38602-5..... 132
 38602D..... 127
 38603..... 132
 38603D..... 127
 38604..... 132
 38606..... 132
 38642..... 133
 38648..... 131
 38661..... 133
 38662..... 133
 38704..... 134
 38705..... 130, 134
 38983..... 130, 134
 38984..... 130, 134
 38985..... 130, 134
 38988..... 130, 134

38990..... 130, 134
 38992..... 130, 134
 38994..... 130, 134
 38996..... 130, 134
 38998..... 130, 134
 38999..... 134
 39004..... 133
 39004-5..... 133
 39004D..... 128
 39005..... 133
 39005-5..... 133
 39005D..... 128
 39006..... 133
 39006D..... 128
 39014..... 133
 39014-5..... 133
 39014D..... 128
 39015..... 133
 39015-5..... 133
 39015D..... 128
 39016..... 133
 39016D..... 128
 39018..... 131
 39018D..... 128
 39020..... 131
 39024..... 133
 39024D..... 128
 39025..... 133
 39025D..... 128
 39026..... 133
 39026D..... 128
 39034..... 133
 39034D..... 128
 39035..... 133
 39035D..... 128
 39036..... 133
 39036D..... 128
 39101..... 95
 39101D..... 128
 39103..... 95
 39103D..... 128
 39104..... 133
 39105..... 133
 39106..... 133
 39114..... 133
 39115..... 133
 39314..... 120
 39316..... 120
 39318..... 120, 121
 39319..... 120
 39320..... 120, 121
 39322..... 120, 121
 39324..... 120, 121
 39325..... 120
 39328..... 120, 121
 39335..... 120
 39336..... 120, 121
 39338..... 120, 121
 39340..... 120, 121
 39342..... 120
 39343..... 120
 39344..... 120
 39346..... 120, 121
 39348..... 120, 121
 39350..... 120
 39352..... 120
 39354..... 120, 121
 39356..... 120, 121
 39358..... 120, 121
 39360..... 120, 121
 39364..... 120
 39368..... 120, 121
 39370..... 120
 39373..... 120
 39411..... 74
 39412..... 74
 39414..... 74
 39415..... 74
 39417..... 74
 39418..... 74
 39420..... 74
 39421..... 74

Numerical Index

39422	74	39911	86	40137J	55	40745J	61	5	189
39505	23	39912	86	40140-6	55	40747J	61	5B	189
39507	24	39914	84	40140HJ	55	40750J	61	5S	217
39508	38	39915	67	40140J	55	40755J	61	5SB	217
39509	26	39915-6	67	40145J	55	40760J	63	500	326
39514	38	39915J	67	40150HJ	55	40762J	63	500100	327
39515	38	39916	67	40150J	55	40905J	64	500100B	327
39516	55	39916-6	67	40155J	55	40905SSJ	229	50050	327
39517	62	39916J	67	40225J	57	40910J	64	50050B	327
39518	59	39917	131	40230J	57	40910SSJ	229	50075	327
39519	61	39920	69	40235J	57	40915J	64	50075B	327
39525	28	39920-6	69	40240J	57	40915SSJ	229	500KC1	327
39526	28	39920J	69	40250J	57	40925J	64	500KC112	327
39527	30	39921	69	40305J	59	40925SSJ	229	500KC114	327
39532	28	39921-6	69	40310J	59	410C	214	500KC1234	327
39534	30	39921J	69	40315J	59	410C100	214	500KC1234B	327
39536	28	39922	69	40317J	59	41110J	56	500KC1B	327
39537	30	39922J	69	40325-6	59	41115J	56	500KC2	327
39538	28	39923	69	40325J	59	41120J	56	50105SSJ	245
39539	31	39923J	69	40326SAEJ	59	41122J	56	50108J	33
39540	31	39926	80	40330J	59	41125J	56	50109J	34
39541	34	39926J	80	40330SAEJ	59	41130J	56	50109SSJ	245
39546	35	39927	80	40335-6	59	41135J	56	50112J	33
39548	42	39927J	80	40335J	59	41140J	56	50113J	34
39551	15	39928	68	40336SAEJ	59	41145J	56	50113SSJ	245
39552	15	39928J	68	40340-6	59	41310J	58	50116J	33
39553	15	39929	68	40340J	59	41315J	58	50117J	34
39554	40	39929J	68	40340SAEJ	59	41320J	58	50117SSJ	245
39555	40	39930	68	40345J	59	41325J	58	50120J	33
39556	16	39931	68	40350J	59	41331J	58	50121J	34
39557	16	39932	68	40402J	57	41336J	58	50121SSJ	245
39558	21	39933	73	40405J	57	41341J	58	50124J	33
39561	18	39933J	73	40410J	63	41415J	58	50125J	34
39562	17	39940	67	40411J	57	41420J	58	50125SSJ	245
39563	44	39940J	67	40412J	63	41425J	58	50128J	33
39564	44	39940-6	67	40414J	63	41430J	58	50132J	33
39565	19			40416J	57	41435J	58	50133J	34
39566	19			40420J	57	42310J	60	50133SSJ	245
39708	85			40425J	57	42315J	60	50140J	33
39710	86			40430J	57	42325J	60	50141J	34
39710-6	86			40435J	57	42330J	60	50141SSJ	245
39711	86			40440J	57	42335J	60	50148J	33
39712	86			40480J	57	42340J	60	50149J	34
39717	87			40481J	57	42345J	60	50149SSJ	245
39718	87			40482J	57	42350J	60	50164J	33
39721	87			40483J	57	42505J	62	50306J	33
39722	87			40505J	62	42510J	62	50308J	33
39723	87			40510J	62	42515J	62	50312J	33
39723-6	87			40515J	62	42517J	62	50316J	33
39724	87			40517J	62	42525J	62	50320J	33
39727	88			40525J	62	42530J	62	50324J	33
39728	88			40530J	62	42535J	62	50325J	34
39747	87			40535J	62	42540J	62	50332J	33
39748	87			40540J	62	42545J	62	50340J	33
39751	87			40545J	62	42550J	62	50348J	33
39752	87			40605J	63	43105J	56	50508J	33
39753	87			40606J	63	43110J	56	50509SSJ	245
39753-6	87			40610J	63	43115J	56	50512J	33
39754	87			40611J	63	43120J	56	50513SSJ	245
39756	87			40615J	63	43122J	56	50516J	33
39757	88			40616J	63	43125J	56	50517SSJ	245
39758	88			40620J	63	43130J	56	50520J	33
39759	87			40621J	63	43135J	56	50524J	33
39761	87			40625J	63	43140J	56	50532J	33
39762	87			40626J	63	43305J	60	50540J	33
39763	87			40705J	61	43310J	60	50548J	33
39763-6	87			40709J	61	43315J	60	50708J	33
39764	87			40710J	61	43320J	60	50709SSJ	245
39767	88			40715J	61	43325J	60	50711SSJ	245
39768	88			40720-6	61	43330J	60	50712J	33
39816	85			40720J	61	43335J	60	50713SSJ	245
39816J	85			40725-6	61	43340J	60	50716J	33
39818	85			40725J	61	43345J	60	50717SSJ	245
39819J	85			40730-6	61	43350J	60	50720J	33
39820	86			40730J	61	43805J	64	50721SSJ	245
39820-6	86			40733J	61	43810J	64	50724J	33
39821	86			40735J	61	43815J	64	50725SSJ	245
39822	86			40740J	61	45432	138	50732J	33
39822J	86			40741J	61	478C	214	50733SSJ	245
39908	85			40743-6	61			50740J	33
39910	86			40743J	61			50748J	33
39910-6	86			40745-6	61			50749SSJ	245

4

5

Numerical Index

50908J	33	52208J	27	53012-6	28	55034	51	55448J	52
50909SSJ	245	52212J	27	53012J	28	55034J	51	55449J	53
50912J	33	52216J	27	53016-6	28	55035J	51	55449USJ	53
50913SSJ	245	52220J	27	53016J	28	55040J	52	55450J	51
50916J	33	52224J	27	53020J	28	55041J	53	55456J	52
50917SSJ	245	52232J	27	53024J	28	55041USJ	53	55464J	52
50920J	33	52240J	27	53032J	28	55048J	52	55512J	50
50924J	33	52248J	27	53040J	28	55049J	53	55516J	50
50925SSJ	245	52249J	35	53048J	28	55049USJ	53	55520J	50
50932J	33	52265J	35	53064J	28	55050	51	55524J	50
50933SSJ	245	52308SS316J	243	53112SS316J	243	55050J	51	55532J	50
50940J	33	52309SSJ	242	53116SS316J	243	55056J	52	55540J	50
50948J	33	52312SS316J	243	53124SS316J	243	55064J	52	55548J	50
50949SSJ	245	52313SSJ	242	53132SS316J	243	55112J	50	55556J	50
51017SSJ	245	52316SS316J	243	53212J	28	55116J	50	55564J	50
51103J	38	52324SS316J	243	53216J	28	55120J	50	55812J	52
51104J	38	52325SSJ	242	53220J	28	55124J	50	55813J	53
51105J	38	52332SS316J	243	53224J	28	55132J	50	55813USJ	53
51107J	38	52333SSJ	242	53232J	28	55140J	50	55816J	51, 52
51108J	38	52356J	27	53248J	28	55148J	50	55817J	53
51109J	38	52364J	27	53264J	28	55156J	50	55817USJ	53
51110J	38	52406-6	27	53608J	246	55164J	50	55820J	51, 52
51111J	38	52406J	27	53612J	246	55208J	52	55821J	53
51112J	38	52408-6	27	53616J	246	55209J	53	55821USJ	53
51113J	38	52408J	27	53708J	38	55209USJ	53	55824J	52
51114J	38	52412-6	27	53712J	38	55212J	52	55825J	53
51115J	38	52412J	27	53716J	38	55213J	53	55825USJ	53
51116J	38	52416-6	27	53808J	38	55213USJ	53	55826J	51
51117J	38	52416J	27	53812J	38	55216J	51, 52	55832J	52
51118J	38	52420-6	27	54108J	54	55217J	53	55833J	53
51208J	45	52420J	27	54110J	54	55217USJ	53	55833USJ	53
51212J	45	52424-6	27	54112J	54	55220J	52	55834J	51
51216J	45	52424J	27	54116J	54	55221J	53	55840J	52
51412J	45	52432-6	27	54120J	54	55221USJ	53	55841J	53
51416J	45	52432J	27	54124J	54	55224J	52	55841USJ	53
51420J	45	52440J	27	54132J	54	55225J	53	55842J	51
51424J	45	52448J	27	54208J	54	55225USJ	53	55848J	52
51432J	45	52508SS316J	243	54212J	54	55227J	51	55849USJ	53
51512J	45	52509SSJ	242	54216J	54	55232J	52	55850J	51
51516J	45	52512SS316J	243	54220J	54	55233J	53	55856J	52
51520J	45	52513SSJ	242	54224J	54	55233USJ	53	55864J	52
51524J	45	52516SS316J	243	54232J	54	55234J	51	56108J	45
51532J	45	52517SSJ	242	54408J	54	55240J	52	56112J	45
51706J	45	52520SS316J	243	54412J	54	55241J	53	56116J	45
51708J	45	52521SSJ	242	54416J	54	55241USJ	53	56312J	45
51712J	45	52528SS316J	243	54420J	54	55242J	51	56316J	45
51716J	45	52529SSJ	242	54424J	54	55248J	52	56320J	45
51720J	45	52606J	27	54432J	54	55256J	52	56324J	45
51724J	45	52608J	27	54440J	54	55264J	52	57016J	49
51806J	45	52612J	27	54448J	54	55312J	50	57020J	49
51808J	45	52616J	27	54456J	54	55316J	50	57024J	49
51812J	45	52620J	27	54464J	54	55320J	50	57032J	49
51816J	45	52624J	27	54812J	54	55324J	50	57040J	49
51820J	45	52632J	27	54816J	54	55332J	50	57048J	49
51824J	45	52648J	27	54820J	54	55340J	50	57056J	49
51832J	45	52708SS316J	243	54824J	54	55348J	50	57064J	49
52008J	35	52709SSJ	242	54828J	54	55356J	50	57216J	49
52012J	35	52712SS316J	243	54832J	54	55364J	50	57220J	49
52016-6	35	52713SSJ	242	54840J	54	55408J	52	57224J	49
52016J	35	52716SS316J	243	54848J	54	55409J	53	57232J	49
52020J	35	52717SSJ	242	54856J	54	55409USJ	53	57240J	49
52024-6	35	52724SS316J	243	54864J	54	55412J	52	57248J	49
52024J	35	52725SSJ	242	55008J	52	55413J	53	57256J	49
52032-6	35	52732SS316J	243	55009J	53	55413USJ	53	57264J	49
52032J	35	52733SSJ	242	55009USJ	53	55416J	52	57416J	49
52048J	35	52809-6	27	55012J	52	55417J	53	57420J	49
52064J	35	52809J	27	55013J	53	55417USJ	53	57424J	49
52108SS316J	243	52813J	27	55013USJ	53	55420J	52	57432J	49
52109SSJ	242	52817J	27	55016J	52	55421J	53	57440J	49
52112SS316J	243	52821J	27	55017J	53	55421USJ	53	57448J	49
52113SSJ	242	52825J	27	55017USJ	53	55422J	51	57456J	49
52116SS316J	243	52833J	27	55020J	52	55424J	52	57464J	49
52117SSJ	242	52908SS316J	243	55021J	53	55425J	53	57472J	49
52124SS316J	243	52912SS316J	243	55021USJ	53	55425USJ	53	57480J	49
52125SSJ	242	52916SS316J	243	55022J	51	55432J	52	57488	49
52132SS316J	243	52920SS316J	243	55024J	52	55433J	53	57496	49
52133J	35	52924SS316J	243	55025J	53	55433USJ	53	57824J	49
52133SSJ	242	52932SS316J	243	55025USJ	53	55434J	51	57832J	49
52149J	35	53006-6	28	55026J	51	55440J	52	57840J	49
52165J	35	53006J	28	55032J	52	55441J	53	57848J	49
52206J	27	53008-6	28	55033J	53	55441USJ	53	57856J	49
52208-6	27	53008J	28	55033USJ	53	55442J	51	57864J	49

Numerical Index

57872	49	59510J	67	600	202	60528NDJ	36	61201	92
57880	49	59512J	68	60002J	72	60528J	37	61202J	92
57888	49	59515J	69	60004J	72	60536NDJ	36	61203J	92
57896	49	59520J	80	60006J	72	60536J	37	61204J	92
58031J	72	59521J	80	60008J	72	60544NDJ	36	61218J	79
58132J	71	59522J	69	60010	202	60544J	37	61226J	79
58133J	71	59604J	96	60011J	72	60552NDJ	36	61232J	79
58148J	71	59604SSJ	256	60012J	72	60552J	37	61413J	76
58149J	71	59605J	96	60014J	72	60560NDJ	36	61413SSJ	239
58164J	71	59605SSJ	256	60016J	72	60560J	37	61421SSJ	239
58165J	71	59606J	96	60018J	72	60564J	37	61422J	76
58231J	72	59606SSJ	256	60020J	72	60602J	81	61422SSJ	239
58332J	71	59608J	96	60026J	72	60604J	81	61431SSJ	239
58333J	71	59608SSJ	256	60028J	72	60606J	81	61513SSJ	239
58348J	71	59610SS	256	60030J	72	60610J	81	61522SSJ	239
58349J	71	59625J	96	600SS316	219	60612J	81	61617J	76
58364J	71	59626J	96	60112SSJ	245	60614	81	61617SSJ	239
58365J	71	59643	93	60116SSJ	245	60616	81	61630J	76
58396J	71	59645	93	60120J	37	60618J	81	61630SSJ	239
58431J	72	59670J	93	60120NDJ	36	60618	81	61631SSJ	239
58496J	71	59671J	93	60124SSJ	245	60720NDJ	36	61640J	76
58531J	72	59672J	93	60128J	37	60728NDJ	36	61640SSJ	239
58548J	71	59673J	93	60128NDJ	36	60728J	37	61641SSJ	239
58549J	71	59674J	94	60132SSJ	245	60736NDJ	36	61651SSJ	239
58564J	71	59675J	94	60136NDJ	36	60736J	37	61661SS	239
58565J	71	59677J	93	60144NDJ	36	60744J	37	61822J	76
58631J	72	59678J	93	60144J	37	60752NDJ	36	61822SSJ	239
58647J	71	59679	94	60152NDJ	36	60752J	37	61830J	76
58648J	71	59680	94	60152J	37	60760NDJ	36	61830SSJ	239
58664J	71	59681	94	60160NDJ	36	60764NDJ	36	61840J	76
58680J	71	59702	94	60160J	37	60764J	37	61840SSJ	239
58696J	71	59703	94	60164NDJ	36	60802J	81	61942SSJ	239
58732	70	59704	94	60164J	37	60804J	81	62003	37
58742	70	59705	94	602	202	60806J	81	62006	37
58743	70	59706	94	60206J	83	60808J	81	62028J	75
58744	70	59708	94	60212J	83	60810J	81	62029J	76
58816	70	59710	94	60214J	83	60812J	81	62036J	75
58817	70	59720	139	60216J	83	60814J	81	62036US	75
58818	70	59722	139	60218J	83	60816J	81	62037	75
58900	70	59724	139	60236	83	61102	36	62052J	75
59011J	78	59726	139	60240	83	61103	36	62052US	75
59012HSJ	78	59728	139	60242	83	61105	130	62053	75
59012J	78	59730	139	60244	83	61107	130	62104SSJ	244
59016-6	78	59732	139	60248	83	61108	130	62106SSJ	244
59016HSJ	78	59734	139	602B	202	61109	130	62108SSJ	244
59016J	78	59736	139	602BSS	219	61111	130	62112SSJ	244
59020-6	78	59738	139	602BSS316	219	61113	130	62116SSJ	244
59020HSJ	78	59740	139	60320J	37	61144J	89	62124SSJ	244
59020J	78	59804	94	60320NDJ	36	61145J	89	62132SSJ	244
59024HSJ	78	59805	94	60328J	37	61147J	89	62236J	75
59024J	78	59806	94	60328NDJ	36	61148J	89	62236US	75
59032HSJ	78	59808	94	60336J	37	61150J	89	62237	75
59032J	78	59810	94	60336NDJ	36	61152J	89	62244J	75
59038HSJ	78	59904	139	60344J	37	61156J	89	62244US	75
59048HSJ	78	59906	139	60344NDJ	36	61157J	89	62245	75
59124J	79	59908	139	60352J	37	61160J	90	62248J	75
59140J	79	59910	139	60352NDJ	36	61162J	90	62248US	75
59156J	79	59912	139	60360NDJ	36	61164J	90	62249	75
59164J	79	59914	139	60364J	37	61166J	90	62260J	75
59248J	47	59916	139	60364NDJ	36	61167J	90	62260US	75
59250	47	59918	139	60402J	82	61168J	90	62280J	75
59251J	47	59920	139	60402SS316J	240	61169J	90	62280US	75
59264	47	59922	139	60402SSJ	240	61170J	90	62298	75
59280	47	59980	139	60404J	82	61172J	90	62298US	75
59408J	85	59982	139	60404SS316J	240	61174J	90	62308SSJ	244
59410J	85	59984	139	60404SSJ	240	61176J	90	62312SSJ	244
59411J	74	59986	139	60405J	82	61177J	90	62316SSJ	244
59412J	85	59987	139	60406J	82	61179J	90	62324SSJ	244
59414J	85	59988	139	60406SSJ	240	61180J	90	62332SSJ	244
59416J	74	59990	139	60408J	82	61181J	90	62444J	75
59417J	74	59991	139	60408SS	240	61182J	89	62444US	75
59418J	74	59992	139	60408SS316	240	61183J	89	62460J	75
59425J	84	59994	139	60410J	82	61185J	91	62460US	75
59431J	87	59996	139	60410SS	240	61186J	91	62468J	75
59432J	87	59998	139	60410SS316	240	61187J	91	62468US	75
59433J	87			60440	82	61188J	91	62488J	75
59440J	88			60444	82	61190	91	62488US	75
59450J	84			60446	82	61194J	92	62498	75
59504J	84			60448	82	61195	92	62498US	75
59505J	84	6B	189	60450	82	61197J	92	62508SSJ	244
59506J	84	6S	217	60520NDJ	36	61198J	92	62512SSJ	244
59507J	84	6SB	217	60520J	37	61200	92	62516SSJ	244

Numerical Index

62520SSJ	244	64364J	48	67498	174	67742	154	70002	98
62524SSJ	244	64380J	48	67499	174	67744	154	70010	202
62528SSJ	244	64396J	48	67509	169	67746	154	70012J	98
62656J	75	64399	48	67510	169	67748	154	70016J	98
62656US	75	64496	48	67511	169	67750	154	70020J	98
62672J	75	64499	48	67512	169	67752	154	70024J	98
62672US	75	64510	48	67551	170	67754	154	70024SSJ	257
62680	75	64512	48	67553	170	67756	154	70032J	98
62680US	75	646R	209	67555	170	67758	154	70040J	98
62696	75	646RS	210	67561	170	67760	154	70048J	98
62696US	75	646RW	209	67563	170	67762	154	701	202
62698US	75	646RWS	210	67565	170	67800	152	70105J	224
62700	75	648R	209	67567	170	67802	152	70105SS316J	224
62700US	75	648RS	210	67569	170	67804	152	70110J	224
62708SSJ	244	648RSS	258	67571	170	67806	152	70110SS316J	224
62712SSJ	244	648RW	209	67573	170	67812	152	70115J	224
62714SSJ	244	648RWS	210	67575	170	67814	152	70115SS316J	224
62716SSJ	244	65000J	46	67577	170	67816	152	70120J	224
62724SSJ	244	65002J	46	67579	170	67818	152	70120SS316J	224
62732SSJ	244	65004J	46	67579CAMO	170	67820	152	70125J	224
62740SSJ	244	65006J	46	67581	170	67822	152	70125SS316J	224
62876	75	65008J	46	67581CAMO	170	67824	152	70130J	224
62876US	75	65010J	46	67583	170	67826	152	70130SS316J	224
62888	75	65012J	46	67583CAMO	170	67828	152	70135J	224
62888US	75	654R	209	67584	170	67830	152	70135SS316J	224
62897	75	654RS	210	67585	365	67832	152	70137J	224
62897US	75	66124J	95	67600	168	67834	152	70137SS316J	224
62898	75	66132J	95	67601	168	67836	152	70140J	224
62898US	75	66140J	95	67602	168	67838	152	70140SS316J	224
62900	75	66148J	95	67604	168	67840	152	70145J	224
62900US	75	66164J	95	67608	168	67842	152	70145SS316J	224
62906SSJ	244	66340J	95	67609	168	67844	152	70150J	224
62907SSJ	244	66348J	95	67611	168	67846	152	70150SS316J	224
62908SSJ	242	66356J	95	67612	168	67848	152	702	202
62910	75	66364J	95	67613	168	68006	73	70205J	225
62910US	75	66400J	46	67618	168	68008	73	70210J	225
62911SSJ	242	66402J	46	67622	168	68010	73	70215J	225
62912SSJ	244	66404J	46	67624	169	68036	123, 146	70220J	225
62915SSJ	242	66406J	46	67625	169	68037	146	70225J	225
62916SSJ	244	66408J	46	67626	169	68038	123, 146	70230J	225
62919SSJ	242	66410J	46	67630	168	68039	146	70235J	225
62920SSJ	244	66412J	46	67632	168	68040	123, 146	70240J	225
62923SSJ	242	66414J	46	67634	168	68041	146	703	202
62924SSJ	244	66466J	47	67636	168	68042	146	70305J	226
62931SSJ	242	66467J	47	67638	168	68044	123, 146	70305SS316J	226
62932SSJ	244	67005	48	67640	168	68046	123, 146	70310J	226
63013SSJ	242	67007	48	67642	168	68047	146	70310SS316J	226
63017SSJ	242	67009	48	67648	168	68049	146	70315J	226
63025SSJ	242	67400	111	67650	168	68080	146	70315SS316J	226
63028J	77	67402	111	67652	168	68084	146	70325J	226
63029	77	67404	111	67654	168	68096	123, 146	70325SS316J	226
63033SSJ	242	67405	111	67658	169	69001	123	70330J	226
63038J	77	67410	111	67661	169	69001D	129	70330SS316J	226
63039	77	67420J	155	67662	169	69002	123	70335J	226
63112SSJ	244	67421J	155	67663	169	69002D	129	70335SS316J	226
63116SSJ	244	67422J	155	67664	169	69003	123	70337J	226
63124SSJ	244	67423J	155	67665	169	69003D	129	70337SS316J	226
63132J	77	67424J	155	67671	169	69004	123	70340J	226
63132SSJ	244	67450	174	67672	169	69004D	129	70340SS316J	226
63144J	77	67452	174	67680	152	69005	123	70345J	226
63238J	77	67454	174	67682	152	69005D	129	70345SS316J	226
63239	77	67456	174	67684	152	69006	123	70350J	226
63256J	77	67458	174	67686	152	69006D	126	70350SS316J	226
63257	77	67460	174	67688	152	69007	123	70405J	225
63276J	77	67462	174	67690	152	69007D	126	70410J	225
63444J	77	67464	174	67692	152	69902	146	70415J	225
63456J	77	67466	174	67694	152	69904	146	70420J	225
63476J	77	67468	174	67696	152	69950	96	70425J	225
634R	209	67470	174	67699	153	69951	96	70430J	225
634RW	209	67472	174	67700	153	69952	96	70435J	225
64024J	48	67474	174	67710	153	69955	96	70440J	225
64032J	48	67476	174	67712	153	69956	96	70445J	225
64040J	48	67478	174	67714	153	69957	96	70450J	225
64048J	48	67480	174	67716	153			70505J	227
64132J	48	67482	174	67718	153			70505SS316J	227
64140J	48	67484	174	67720	153			70510J	227
64148J	48	67486	174	67722	153	7	189	70510SS316J	227
64164J	48	67488	174	67724	153	7B	189	70515J	227
64180J	48	67490	174	67726	153	7S	217	70515SS316J	227
64252J	48	67492	174	67728	153	7SB	217	70525J	227
64264J	48	67494	174	67730	153	700	202	70525SS316J	227
64280J	48	67496	174	67740	154	70000	98	70530J	227

Numerical Index

70530SS316J	227	71440J	250	74224SS316J	232	74450SS316J	236	74834SS316J	237
70535J	227	71448J	250	74226J	234	74456J	230	74840J	231
70535SS316J	227	71921	256	74226SS316J	236	74456SS316J	232	74840SS316J	233
70537J	227	71922	256	74232J	230	74458J	234	74842J	235
70537SS316J	227	71923	256	74232SS316J	232	74458SS316J	236	74842SS316J	237
70540J	227	71924	256	74234J	234	74464J	230	74848J	231
70540SS316J	227	71931	256	74234SS316J	236	74464SS316J	232	74848SS316J	233
70545J	227	71932	256	74236J	230	74466J	234	74850J	235
70545SS316J	227	71933	256	74236SS316J	232	74466SS316J	237	74850SS316J	237
70550J	227	71934	256	74238J	234	74480	231	74856	231
70550SS316J	227	71961	256	74238SS316J	236	74480SS316J	232	74856SS316	233
70608J	250	71962	256	74240J	230	74482J	235	74858	235
70612J	250	71963	256	74240SS316J	232	74482SS316J	237	74858SS316	237
70616J	250	71964	256	74242J	234	74496	231	74864	231
70620J	250	72010	97	74242SS316J	236	74496SS316	233	74864SS316	233
70709J	228	72010SS	257	74248J	230	74498	235	74866	235
70709SS316J	228	72011	97	74248SS316J	232	74498SS316	237	74866SS316	237
70710J	228	72012	97	74250J	234	74612J	231, 235	74896	231
70720J	228	72012SS	257	74250SS316J	236	74612SS316J	233, 237	74896SS316	233
70720SS316J	228	72013	97	74266SS316J	236	74616J	231, 235	74898	235
70725J	228	72014	97	74282SS316J	236	74616SS316J	233, 237	74898SS316	237
70725SS316J	228	72015	97	74308J	230, 234	74620J	231, 235	74924J	238
70730J	228	72016	97	74308SS316J	232, 236	74620SS316J	233, 237	74932J	238
70730SS316J	228	72018	97	74312J	230, 234	74624J	231	74948J	238
70733J	228	72020	97	74312SS316J	232, 236	74624SS316J	233	75016J	231, 235
70733SS316J	228	72608J	251	74316J	230, 234	74626J	235	75016SS316J	233, 237
70735J	228	72612J	251	74316SS316J	232, 236	74626SS316J	237	75024J	231, 235
70735SS316J	228	72616J	251	74320J	230	74628J	231	75024SS316J	233, 237
70740J	228	72620J	251	74320SS316J	232	74628SS316J	233	75032J	231
70740SS316J	228	72726J	252	74322J	234	74630J	235	75032SS316J	233
70741J	228	72736J	252	74322SS316J	236	74630SS316J	237	75034J	235
70743J	228	72748J	252	74324J	230	74632J	231	75034SS316J	237
70743SS316J	228	72808J	251	74324SS316J	232	74632SS316J	233	75040J	231
70745J	228	72810J	251	74326J	234	74634J	235	75040SS316J	233
70745SS316J	228	72812J	251	74326SS316J	236	74634SS316J	237	75042J	235
70746J	228	72816J	251	74328J	230	74636J	231	75042SS316J	237
70746SS316J	228	72820J	251	74328SS316J	232	74636SS316J	233	75048	231
70749J	228	72824J	251	74330J	234	74638J	235	75048SS316	233
70750J	228	72828J	251	74330SS316J	236	74638SS316J	237	75050	235
70750SS316J	228	72832J	251	74332J	230	74640J	231	75050SS316	237
70755J	228	72840J	251	74332SS316J	232	74640SS316J	233	75056	231
70755SS316J	228	72848J	251	74334J	234	74642J	235	75056SS316	233
70808J	250	73012J	251	74334SS316J	236	74642SS316J	237	75058	235
70810J	250	73016J	251	74340J	230	74648J	231	75058SS316	237
70812J	250	73020J	251	74340SS316J	232	74648SS316J	233	75124J	238
70816J	250	73024J	251	74342J	234	74650J	235	75132J	238
70820J	250	73028J	251	74342SS316J	236	74650SS316J	237	75148J	238
70824J	250	73032J	251	74348J	230	74652J	231	75156J	238
70832J	250	73040J	251	74348SS316J	232	74652SS316J	233	75164J	238
70906J	227	73048J	251	74350	234	74654J	235	75172J	238
70911J	227	73216J	251	74350SS316J	236	74656J	231	75180J	238
70916J	227	73220J	251	74356J	230	74656SS316J	233	75220J	238
70925J	227	73224J	251	74356SS316J	232	74658J	235	75224J	238
70935J	227	73228J	251	74358J	234	74658SS316J	237	75232J	238
70941J	227	73232J	251	74358SS316J	236	74664J	231	75248J	238
71000	96	73240J	251	74408J	230, 234	74664SS316J	233	75264J	238
71001	96	73248J	251	74408SS316J	232, 236	74666J	235	75332J	238
71008J	250	73416J	251	74412J	230, 234	74666SS316J	237	75348J	238
71010J	250	73420J	251	74412SS316J	232, 236	74672J	231	75364J	238
71012J	250	73424J	251	74414J	230, 234	74672SS316J	233	75608J	251
71016J	250	73432J	251	74414SS316J	232, 236	74674J	235	75612J	251
71020J	250	73440J	251	74416J	230, 234	74674SS316J	237	75616J	251
71024J	250	73448J	251	74416SS316J	232, 236	74680J	231	75812J	251
71032J	250	74002	97	74420J	230	74680SS316J	233	75816J	251
71040J	250	74010	97	74420SS316J	232	74682J	235	75820J	251
71105J	229	74011	97	74422J	234	74682SS316J	237	75832J	251
71110J	229	74013	97	74422SS316J	236	74688	231	76012J	251
71115J	229	74014	97	74424J	230	74688SS316	233	76016J	251
71120J	229	74206J	230, 234	74424SS316J	232	74690	235	76020J	251
71125J	229	74208J	230, 234	74426J	234	74690SS316	237	76024J	251
71135J	229	74208SS316J	232, 236	74426SS316J	236	74816	231	76028J	251
71212J	250	74210J	230, 234	74432J	230	74816J	235	76032J	251
71216J	250	74210SS316J	232, 236	74432SS316J	232	74816SS316J	233, 237	76040J	251
71220J	250	74212J	230, 234	74434J	234	74820	231	76048J	251
71224J	250	74212SS316J	232, 236	74434SS316J	236	74820J	235	76108J	238
71232J	250	74216J	230, 234	74440J	230	74820SS316J	233, 237	76112J	238
71240J	250	74216SS316J	232, 236	74440SS316J	232	74824	231	76116J	238
71412J	250	74220J	230	74442J	234	74824J	235	76140J	238
71416J	250	74220SS316J	232	74442SS316J	236	74824SS316J	233, 237	76224J	238
71420J	250	74222J	234	74448J	230	74832J	231	76312J	238
71424J	250	74222SS316J	236	74448SS316J	232	74832SS316J	233	76324J	238
71432J	250	74224J	230	74450J	234	74834J	235	76332J	238

Numerical Index

76348J	238	78616SSJ	255	79625-6	44	80913	140	85013	142
76424J	238	78808-6	25	79625J	44	80914	140	85014	142
76528J	241	78808J	25	79626-6	43	80916	140	85015	142
76536J	241	78808SSJ	255	79626J	43	80918	140	85016	142
76552J	241	78810J	25	79627J	43	80920	140	85018	142
76608J	18	78812-6	25	79628-6	44	81008SSJ	249	85020	142
76610J	18	78812J	25	79628J	44	81010SSJ	249	85022	142
76612J	18	78812SSJ	255	79629-6	44	81012SSJ	249	85024	142
76616J	18	78816-6	25	79629J	44	81016SSJ	249	86209	144
76620J	18	78816J	25	79630J	43	81020SSJ	249	86212	144
76624J	18	78816SSJ	255	79632-6	43	81024SSJ	249	86214	144
76736J	241	78820J	25	79632J	43	81032SSJ	249	86216	144
76748J	241	78824J	25	79634-6	44	81048SSJ	249	86217	144
76760J	241	78824SSJ	255	79634J	44	81208SSJ	249	86218	144
76780J	241	78832SSJ	255	79635-6	44	81212SSJ	249	86219	144
76808J	18	79008-6	25	79635J	44	81216SSJ	249	86220	144
76808SSJ	252	79008J	25	79636J	43	81220SSJ	249	86222	144
76810J	18	79008SSJ	255	79637-6	44	81224SSJ	249	86224	144
76812J	18	79010J	25	79637J	44	81232SSJ	249	86226	144
76812SSJ	252	79012-6	25	79840J	43	81248SSJ	249	86228	144
76816J	18	79012J	25	79841J	44	81412SSJ	249	86232	144
76820J	18	79012SSJ	255	79843-6	44	81424SSJ	249	86234	144
76820SSJ	252	79016-6	25	79843J	44	81806	141	86236	144
76824J	18	79016J	25	79845J	43	81807	141	86238	144
76832J	18	79016SSJ	255	79848J	43	81808	141	86240	144
76840J	18	79020-6	25	79849J	44	81809	141	86242	144
76848J	18	79020J	25	79850J	43	81810	141	86244	144
76944J	241	79024-6	25	79851-6	44	81811	141	86246	144
76960J	241	79024J	25	79851J	44	81812	141	86248	144
76968J	241	79024SSJ	255	79964J	43	81813	141	86252	144
76988	241	79028J	25	79965J	44	81814	141	86254	144
76998	241	79032-6	25	79972J	43	81815	141	86256	144
77008-6	17	79032J	25	79980*	43	81816	141	86258	144
77008J	17	79032SSJ	255	79981*	44	81817	141	86260	144
77010J	18	79040J	25	79997*	44	81818	141	86264	144
77012-6	17	79048J	25			81820	141	86266	144
77012J	17	79212-6	25			81822	141	86268	144
77012SSJ	252	79212J	25			81824	141	86270	144
77016-6	17	79212SSJ	255			82009	141	86272	144
77016J	17	79216-6	25			82012	141	86276	144
77016SSJ	252	79216J	25			82018	141	86280	144
77020-6	17	79216SSJ	255			82024	141	86284	144
77020J	17	79220J	25			82204	140	86288	144
77020SSJ	252	79221J	25			82205	140	86292	144
77024-6	17	79224J	25			82206	140	86296	144
77024J	17	79224SSJ	255			82207	140	86298	144
77024SSJ	252	79232J	25			82208	140	86301	145
77028J	18	79240J	25			82303	140	86302	145
77032-6	17	79248J	25			82304	140	86303	145
77032J	17	79412J	25			82305	140	86304	145
77032SSJ	252	79412SSJ	255			82306	140	86305	145
77040J	18	79416J	25			82307	140	86306	145
77048J	18	79416SSJ	255			82308	140	86314	145
77156J	241	79420J	25			82404	140	86322	145
77166J	241	79424J	25			82405	140	86328	145
77180J	241	79432J	25			82406	140	86338	145
77196	241	79440J	25			82408	140	86511	143
77208J	18	79448J	25			82608J	24	86512	143
77208SSJ	252	79448SSJ	255			82610J	24	86514	143
77212J	18	79505-6	21			82612J	24	86522	144
77212SSJ	252	79505J	21			82616J	24	86528	145
77216J	18	79508-6	21			82808J	24	86530	145
77220J	18	79508J	21			82810J	24	86545	145
77224J	18	79512-6	21			82812J	24	86553	366
77232J	18	79512J	21			82816J	24	86556	145
77240J	18	79516-6	21			82820J	24	86561	143
77248J	18	79516J	21			82824J	24	86562	143
77408J	18	79524-6	21			83008J	24	86563	143
77412J	18	79524J	21			83010J	24	86564	143
77416J	18	79532-6	21			83012J	24	86618	148
77416SSJ	252	79532J	21			83016J	24	86624	148
77420J	18	79616J	43			83020J	24	86632	148
77420SSJ	252	79617J	44			83024J	24	86633	148
77424J	18	79618J	43			85004	142	86634	148
77432J	18	79619J	44			85005	142	86637	148
77440J	18	79620-6	44			85006	142	86638	148
77448J	18	79620J	44			85007	142	86640	148
78606J	25	79622-6	44			85008	142	86641	148
78606SSJ	255	79622J	44			85009	142	86644	148
78608J	25	79623J	43			85010	142	86650	148
78612J	25	79624-6	43			85011	142	86655	148
78616J	25	79624J	43			85012	142	86660	148

8

8	189
8B	189
8S	217
8SB	217
80006-6	65
80006J	65
80007	65
80011J	65
80014	174
80015	65
80016	65
80017-6	65
80017J	65
80018	65
80020	65
80021	65
80022J	65
80606SSJ	249
80608	141
80608SSJ	249
80609	141
80610	141
80612	141
80612SSJ	249
80613	141
80614	141
80615	141
80616	141
80616SSJ	249
80618	141
80620	141
80622	141
80624	141
80624SSJ	249
80806SSJ	249
80808SSJ	249
80812SSJ	249
80816SSJ	249
80820SSJ	249
80824SSJ	249
80832SSJ	249
80910	140
80911	140
80912	140

Numerical Index

86665	148
86670	148
86708	143
86712	143
86714	143
86718	143
86722	143
86724	143
86922	142
86924	142
86928	142
86934	142
86941	142
86958	142
86980	151
88602	142
88703	142

9

9	189
9B	189
9S	217
9SB	217
90010	175
90020	175
90024	175
90028	175
90032	175
90036	175
90040	175
90050	175
90052	175
90054	175
90056	175
90058	175
90060	175
90062	175
90064	175
90066	175
90068	175
90072	175
90074	175
90100	211
90108	200
90108J	200
90109	201
90112	200
90113	201
90116	200
90116J	200
90117	201
90214	149
90215	149
90228	149
90229	149
90500	211
90505	211
90600	211
90605	211
91597	135
91599	135
91600	135
91601	135
91601D	129
91602	135
91602D	129
91603	135
91603D	129
91604	135
91604D	129
91605	135
91605D	129
91606	135
91606D	129
91607	135
91607D	129
91608	135
91608D	129
91609	135
91609D	129

91610	135
91610D	129
91611	135
91611D	129
91612	135
91612D	129
91613	135
91613D	129
91614	135
91615	135
91616	135
91617	135, 146
91617D	129
91618	135
91619	135
91620	135
91621	135
91621D	129
91622	135
91623	135
91624	135, 146
91625	135
91625D	129
91626	135
91627	135
91628	135
91629	135
91629D	129
91707	135, 146
91707D	129
9170F	146
91721	135, 146
91721D	129
91725	135, 146
91725D	129
91729	135, 146
91729D	129
91736	146
91736D	129
91801	135
91802	136
91805	138
91806	135
91807	138
91901	136
91901D	129
91902	136
91902D	129
91903	136
91903D	129
91904	136
91904D	129
91905	136
91905D	129
91906	136
91906D	129
91907	136
91907D	129
91908	136
91908D	129
91909	136
91909D	129
91910	136
91910D	129
91911	136
91911D	129
91912	136
91912D	129
91913	136
91913D	129
91914	136
91914D	129
91915	136
91915D	129
91916	136
91916D	129
91917	136
91917D	129
91918	136
91918D	129
91919	136
91919D	129

91920	136
91920D	129
91921	136
91921D	129
91922	136
91922D	129
91923	136
91923D	129
91924	136
91924D	129
91925	136
91925D	129
91926	136
91926D	129
91927	136
91927D	129
91928	136
91928D	129
91929	136
91929D	129
91945	136
91949	136
92050	140
92051	140
92052	140
92053	140
92054	140
92055	140
92056	140
92057	140
92058	140
92500	130
92600	130
92602	130, 131
92627	137
92628	137
92629	137
92630	137
92631	137
92632	137
92706	130, 134
92707	130, 134
92709	130, 134
92710	130, 134
92711	130, 134
92718	130, 134
92720	130, 134
94006	364
94008	364
9410A	213
94315	156
94317	156
94320	156
94325	156
94330	157
94340	157
94352	363
94353	363
94357	157
94361	156
94362	156
94363	156
94364	156
94365	156
94366	156
94368	156
94369	156
94394	157
94396	157
94410	364
94412	364
94422	98
94426	98
94428	98
94430	98
94433	157
94434	157
94435	157
94436	157
94454	364
94456	364
94466	364

94605	158
94606	158
94607	158
94614	158
94615	158
94616	158
94617	158
94618	158
94625	158
94628	158
94635	158
94636	158
94638	158
94639	158
94640	158
94641	158
95000	171
95002	171
95004	171
95006	171
95008	171
95010	171
95012	171
95014	171
95031	171
95032	171
95033	171
95034	171
95035	171
95050	66
95052	66
95054	66
95070	66
95072	66
95074	66
95090	155
95092	155
95094	155
95096	155
95098	155
95100	155
95102	155
95120	171
95122	171
95124	171
95126	171
95128	171
95130	171
95132	171
95134	171
95136	171
95138	171
95150	66
95151	66
95152	66
95154	66
95156	66
95158	66
95168	66
95170	66
95190	66
95192	66
95194	66
95328	366
96000	112
96002	117
96010	113
96030	113
96035	114
96040	113
96042	146
96046	147
96047	147
96050	113
96055	117
96058	117
96059	117
96060	113
96062	117
96064	117
96066	117
96070	112

96071	112
96140	113
96150	113
96160	171
96230	116
96232	117
96234	116
96236	116
96238	116
96240	116
96242	116
96244	116
96246	117
96248	117
96260	148

A

A0600	203
A0600B	203
A1600	203
A1600B	203
A2-1/2 600	203
A2-1/2 600B	203
A2600	203
A2600B	203
A3600	203
A3600B	203
A4600	203
A4600B	203
A5600	203
A5600B	203
AB12EG	280
AB16EG	280
AB18EG	280
AB24EG	280
AB8EG	280
ABC25	330
ABC25R1438N	329
ABC25R14T	329
ABC25R38T	329
APS	317
APS100	317
APS50	317
APS75	317
APSKC1	317
APSKC1234	317

B

BA	215
BA50	333
BA75	333
BAKC1234	333
BAKC38	333
BAR	337
BBC	342
BC075EG	281
BC18	326
BC18100	319
BC1850	319
BC1875	319
BC18KC1	319
BC18KC112	319
BC18KC114	319
BC18KC1234	319
BC18KC2	319
BC18KC38	319
BC18ST	326
BC3787EG	281
BC5087EG	281
BC516	326
BC516100	319
BC51650	319
BC51675	319
BC516KC1	319
BC516KC112	319
BC516KC114	319
BC516KC1234	319
BC516KC2	319
BC516KC38	319
BC516ST	326

Numerical Index

BC916	326	BO	215	CA3HLS6	222	CCC250CP	264	CCOD900EG	266
BC916KC1	319	BR3H0850EG	289	CA4H3WEG	275	CCC300CP	264	CCOP100	264
BC916KC112	319	BR3H1050EG	289	CA4H3WS4	220	CCC350CP	264	CCOP125	264
BC916KC114	319	BR6H1250EG	290	CA4H3WS6	223	CCC400CP	264	CCOP150	264
BC916KC1234	319	BR6H1450EG	290	CA4HEG	273	CCC500CP	264	CCOP200	264
BC916KC2	319	BRB6H1650EG	290	CA4HS4	220	CCC600CP	264	CCOP200R	264
BC916KC38	319	BRB6H1850EG	290	CA4HS6	222	CCE037EG	264	CCOP250	264
BC916ST	326	BRB6H2050EG	290	CAA2H262EG	277	CCE050EG	264	CCOP300	264
BCAS12EG	281	BRC16212EG	291	CAA2H487EG	277	CCE075EG	264	CCOP350	264
BCAS15EG	281	BRC16218EG	291	CAA2H687EG	277	CCE100EG	264	CCOP400	264
BCAS6EG	281	BRC16224EG	291	CAA3H262EG	277	CCE125EG	264	CCOP50	264
BCAS9EG	281	BRC16226EG	291	CAA3H50EG	279	CCE150EG	264	CCOP75	264
BCHD37162EG	282	BRC16229EG	291	CAA4H862EG	278	CCE200EG	264	CCP037YC	268
BCHD3787EG	282	BRC162B12EG	292	CAA4HEG	279	CCOD025EG	265	CCP050YC	268
BCHD50162EG	282	BRC162B18EG	292	CAAG2HEG	277	CCOD037EG	265	CCP075YC	268
BCHD5087EG	282	BRC162B24EG	292	CAAG4H662EG	278	CCOD050EG	265	CCP100YC	268
BCHD62162EG	282	BRC162B30EG	292	CAC2H45EG	278	CCOD062EG	265	CCP125YC	268
BCHD6287EG	282	BRC162B36EG	292	CAC2H45S4	220	CCOD075EG	265	CCP150YC	268
BCJH036EG	281	BRC162D12EG	291	CAC2H45S6	223	CCOD087EG	265	CCP200YC	268
BCJH069EG	281	BRC162D18EG	291	CAC4H45EG	279	CCOD100EG	265	CCP250YC	268
BCJH912EG	281	BRC162D24EG	291	CAG4H3WEG	276	CCOD112EG	265	CCP300YC	268
BCM37EG	287	BRC162D30EG	291	CAG5H3WEG	276	CCOD125EG	265	CCP350YC	268
BCM37PL	287	BRC162D36EG	291	CAGL4HEG	276	CCOD137EG	265	CCP400YC	268
BCM50EG	287	BRC162EG	291	CAGR4HEG	277	CCOD150EG	265	CCP500YC	268
BCM50PL	287	BRC162ND12EG	292	CAGX3HEG	274	CCOD162EG	265	CCR025EG	263
BCM62EG	287	BRC162ND18EG	292	CAGX5HEG	275	CCOD175EG	265	CCR037EG	263
BCM62PL	287	BRC162ND24EG	292	CANT2HEG	273	CCOD187EG	265	CCR050EG	263
BCSA	281	BRC162ND6EG	292	CAO2H45EG	278	CCOD200EG	265	CCR050S4	221
BCSC251EG	282	BRC162ND9EG	292	CAO2H45S4	220	CCOD212EG	265	CCR050S6	223
BCSC371EG	282	BRC162NU12EG	292	CAO2H45S6	223	CCOD225EG	265	CCR075EG	263
BCSCP37250EG	283	BRC162NU18EG	292	CAO4H45EG	278	CCOD237EG	265	CCR075S4	221
BCSD162EG	285	BRC162NU24EG	292	CAOFF4HEG	278	CCOD250EG	265	CCR075S6	223
BCSD325EG	285	BRC162NU6EG	292	CAOFF4HLEG	278	CCOD262EG	265	CCR1000EG	263
BCSNTG	285	BRC162NU9EG	292	CAOFF4HREG	278	CCOD275EG	265	CCR100EG	263
BCSSCDHDEG	283	BRC162W12EG	291	CAP4HEG	275	CCOD287EG	265	CCR100S4	221
BCSSCEG	283	BRC162W18EG	291	CAUG7HEG	276	CCOD300EG	265	CCR100S6	223
BCSU162EG	284	BRC162W24EG	291	CAX2HEG	274	CCOD312EG	265	CCR1200EG	263
BCSU162S4	220	BRC162W6EG	291	CAX2HS4	220	CCOD325EG	265	CCR125EG	263
BCSU162S6	222	BRC325EG	290	CAX2HS6	222	CCOD337EG	265	CCR125S4	221
BCSU325EG	284	BRL0237EG	293	CBS18HIC100	321	CCOD350EG	265	CCR125S6	223
BCSU325S4	220	BRL0437EG	293	CBS18HIC100APS	322	CCOD362EG	265	CCR150EG	263
BCSU325S6	222	BRL0637EG	293	CBS18HIC100ST	321	CCOD375EG	265	CCR150S4	221
BCSU650EG	285	BRL0837EG	293	CBS18HIC50	321	CCOD387EG	265	CCR150S6	223
BCSUJ162LEG	284	BRL1037EG	293	CBS18HIC50APS	322	CCOD400EG	265	CCR200EG	263
BCSUJ162MEG	284	BRS15	210	CBS18HIC50ST	321	CCOD412EG	265	CCR200S4	221
BCSUJ162SEG	284	BRS2	210	CBS18HIC5018	332	CCOD425EG	265	CCR200S6	223
BCSUJ325LEG	284	BRS110EG	289	CBS18HIC50516	332	CCOD437EG	265	CCR250EG	263
BCSUJ325MEG	284	BRS12EG	289	CBS18HIC7518	332	CCOD450EG	265	CCR250S4	221
BCSUJ325SEG	284	BRS114EG	289	CBS18HIC75516	332	CCOD462EG	265	CCR250S6	223
BCSW	283	BRS116EG	289	CBS18HIC10018	332	CCOD475EG	265	CCR300EG	263
BCSZ371EG	283	BRS118EG	289	CBS18HIC100516	332	CCOD487EG	265	CCR300S4	221
BCUBM25EG	288	BRS116EG	289	CBS18HIC75	321	CCOD500EG	266	CCR300S6	223
BCUM37EG	286	BRS118EG	289	CBS18HIC75APS	322	CCOD512EG	266	CCR350EG	263
BCUM37PL	286	BRSR10EG	289	CBS18HIC75ST	321	CCOD525EG	266	CCR350S4	221
BCUM50EG	286	BRSR12EG	289	CBS18KC1	321	CCOD537EG	266	CCR350S6	223
BCUM50PL	286	BRSR14EG	289	CBS18KC118	332	CCOD550EG	266	CCR400EG	263
BCUM62EG	286	BRSR16EG	289	CBS18KC1234	321	CCOD562EG	266	CCR400S4	221
BCUM62PL	286	BRSR18EG	289	CBS18KC123418	332	CCOD575EG	266	CCR400S6	223
BCUM75EG	286	BRSR6EG	289	CBS18KC1234516	332	CCOD587EG	266	CCR500EG	263
BCUM75PL	286	BRSR8EG	289	CBS18KC1234APS	322	CCOD600EG	266	CCR500S4	221
BCUMW37EG	287	BS18	204	CBS18KC1234ST	321	CCOD612EG	266	CCR500S6	223
BCUMW37PL	287	BST	205	CBS18KC1516	332	CCOD625EG	266	CCR600EG	263
BCUMW50EG	287	BXC	333	CBS18KC1APS	322	CCOD637EG	266	CCR600S4	221
BCUMW50PL	287			CBS18KC1ST	321	CCOD650EG	266	CCR600S6	223
BCUMW62EG	287			CBS18KC38	321	CCOD662EG	266	CCR800EG	263
BCUMW62PL	287			CBS18KC3818	332	CCOD675EG	266	CCR800S4	221
BJNP	211	CA1H387EG	279	CBS18KC38516	332	CCOD687EG	266	CCR800S6	223
BJNPH	211	CA1H587EG	279	CBS18KC38APS	322	CCOD700EG	266	CCT025YC	267
BJW4	215	CA1H787EG	279	CBS18KC38ST	321	CCOD712EG	266	CCT037YC	267
BJW6	215	CA1H987EG	279	CC1538P(B)	353	CCOD725EG	266	CCT050YC	267
BMB16	337	CA2H350LEG	273	CC1538Q	359	CCOD737EG	266	CCT062YC	267
BMB16D	337	CA2H3LEG	273	CC2025Q	359	CCOD750EG	266	CCT075YC	267
BMB16T	337	CA2H4LEG	274	CC2050Q	359	CCOD762EG	266	CCT087YC	267
BMB1624T	337	CA2HEG	273	CCC025CP	264	CCOD775EG	266	CCT100YC	267
BMB164S3P	337	CA2HS4	220	CCC037CP	264	CCOD787EG	266	CCT112YC	267
BMB164SL	337	CA2HS6	222	CCC050CP	264	CCOD812EG	266	CCT125YC	267
BMB1624T	337	CA3H3WEG	275	CCC075CP	264	CCOD825EG	266	CCT137YC	267
BMB24	337	CA3H3WS4	220	CCC100CP	264	CCOD837EG	266	CCT150YC	267
BMB244S4P	337	CA3H3WS6	222	CCC125CP	264	CCOD850EG	266	CCT162YC	267
BMB244SL	337	CA3HEG	273	CCC150CP	264	CCOD862EG	266	CCT175YC	267
BMB24D	337	CA3HLEG	274	CCC200CP	264	CCOD875EG	266	CCT187YC	267
BMB24T	337	CA3HLS4	220			CCOD887EG	266	CCT200YC	267

C

Numerical Index

CCT212YC 267
 CCT225YC 267
 CCT250YC 267
 CCT262YC 267
 CCT312YC 267
 CCT362YC 267
 CCT412YC 267
 CCU050EG 263
 CCU075EG 263
 CCU100EG 263
 CCU125EG 263
 CCU150EG 263
 CCU200EG 263
 CG1525K 359
 CG1538K 359
 CG1538M(B) 353
 CG1738K 359
 CG2038M(B) 353
 CG2050Q 359
 CG2063T(B) 353
 CG3090N(B) 353
 CGP3HEG 271
 CGP4HEG 271
 CGP5HEG 272
 CIEG 293
 CIN25EG 293
 CIN25PL 293
 CIN37EG 293
 CIN37PL 293
 CIN50EG 293
 CIN50PL 293
 CIN62EG 293
 CIN62PL 293
 CIN75EG 293
 CIN75PL 293
 CIN87EG 293
 CIN87PL 293
 CIPL 293
 CLE050 268
 CLE075 268
 CLE100 268
 CLT025 268
 CLT037 268
 CLT050 268
 CLT062 268
 CLT075 268
 CLT087 268
 CLT112 268
 CNNO10EG 261
 CNNO25EG 261
 CNNO25S6 222
 CNNO31EG 261
 CNNO37EG 261
 CNNO37S6 222
 CNNO50EG 261
 CNNO50S6 222
 CNNO62EG 261
 CNNO75EG 261
 CNNT050EG 261
 CNNT050S6 222
 CNNT062EG 261
 CNNT075EG 261
 CNNT087EG 261
 CP1225K 358
 CP1525K 358
 CP1531K 358
 CP1550K 358
 CP1725K 358
 CP2025K 358
 CP2775S 358
 CP3HEG 271
 CP3HS4 220
 CP3HS6 222
 CP4HEG 271
 CPC50EG 296
 CPC75EG 296
 CPRS25J 154
 CSA4HSPEG 296
 CSA4HTPEG 296
 CULWMO45 176
 CULWMO9 176
 CULWMO9LT 176

CULWMI130 176
 CULWMI190 176
 CULWMI190AZ 176
 CULWMI4690 176
 CULWMIABC 176
 CULWMIAMZ 176
 CULWMIAMZ015 176
 CULWMIAMBA 177
 CULWMIAMFA 177
 CULWMIAMINST 176
 CULWMIAML1 176
 CULWMIAMNEMA 177
 CULWMIAMT1 176
 CULWMIAMVOLT 177

D

DB1538K 354
 DB1538K-B50 355
 DB1550K 354
 DB1550K-B50 355
 DB1738K 354
 DB1738K-B50 355
 DB1763Q 354
 DB1763Q-B50 355
 DB2038E 354
 DB2038E-B50 355
 DB2050Q 354
 DB2050Q-B50 355
 DB2063Q 354
 DB2063Q-B50 355
 DB2063S 354
 DB2063S-B50 355
 DB2075S 354
 DB2075S-B50 355
 DB2575S 354
 DB2575S-B50 355
 DB2588S 354
 DB2588S-B50 355
 DB2592S 354
 DB2592S-B50 355
 DB3075S 354
 DB3075S-B50 355
 DB3090W 354
 DB3090W-B50 355
 DB3095W 354
 DB3095W-B50 355
 DB3097W 354
 DB3097W-B50 355
 DB4097W 354
 DC1025C 356
 DC1225C 356
 DC1531I 356
 DC1738I 356
 DC2050Q 356
 DC2063Q 356
 DC2063S 356
 DG1538K 356
 DG1575E 356
 DG1738K(S) 357
 DG2050Q 356
 DG2063Q 356
 DG2063Q-#4 357
 DG2063Q-#6 357
 DG2075S 356
 DG2090S 356
 DG2588S 356
 DG2590S 356
 DG3090W 356
 DG3090W(H) 356
 DG3097W 356
 DG3597W 356
 DLS1 206
 DR20 212
 DR30 212
 DR40 212
 DWC1 207
 DZ1738K 355
 DZ2063Q 355
 DZ2063Q(F) 357
 DZ2063Q(F)-X2 357
 DZ2063S(S) 357

DZ3090W 355

E

EC16212GAEG 294
 EC16214GAEG 294
 EC8114GAEG 294
 ECK050EG 295
 ECK075EG 295
 ECP162R 294
 ECP162W 294
 ECP325R 294
 ECP325W 294
 ECP81R 294
 ECP81W 294
 ES1150 150
 ES137S 150
 ES200S 150
 ES200SV 150

F

F2A 318
 F2B 318
 F2C 318
 F2D 318
 F2E 318
 F2F 318
 F2G 318
 F4A 318
 F4B 318
 F4C 318
 F4D 318
 F4E 318
 F4F 318
 F4G 318
 F8A 318
 F8B 318
 F8C 318
 F8D 318
 F8E 318
 F8F 318
 F8G 318
 FB023 205
 FB023DS 205
 FB023HD 205
 FB0234 205
 FB0234DS 205
 FB06 205
 FB023 205
 FB0234 205
 FB06 205
 FCWS6 315
 FFZB3HEG 312
 FH116 331
 FH16256EG 295
 FH16287EG 295
 FH32556EG 295
 FH32587EG 295
 FH532 331
 FMBS184S 204
 FS1 316
 FS2 316
 FS3 316
 FS4 316
 FSBX 316
 FSD 395
 FT 339
 FZB8HEG 312
 FZCH162EG 312
 FZCH243EG 312
 FZCH325EG 312
 FZS2H4EG 311
 FZS2H5EG 311
 FZS2H6EG 311
 FZS2H7EG 311
 FZS2H8EG 311
 FZS02HEG 310
 FZSSEG 311
 FZX2H162EG 310
 FZX2H162S4 221
 FZX2H162S6 223

FZX2H1EG 310
 FZX2H243EG 310
 FZX2H325EG 310
 FZX2H81EG 310

G

G100 210

H

H12 198
 H16 198
 H16A 198
 H30 192
 H40 192
 H45 192
 H50 192
 H55 192
 H60 192
 H65 192
 H70 192
 H75 192
 H80 192
 H85 192
 H90 192
 H92 192
 H94 192
 H95 192
 H96 192
 H97 192
 H98 192
 HD260 197
 HD270 197
 HD280 197
 HD290 197
 HD292 197
 HD294 197
 HD295 197
 HD296 197
 HD297 197
 HD298 197
 HIC100 314
 HIC50 314
 HIC5050 315
 HIC5075 315
 HIC75 314
 HIC7575 315

I

I10A 347
 I10C 347
 I10G 347
 I10HA 347
 I10HC 347
 I10HFA 347
 I10HFC 347
 I10HFG 347
 I10HFR 347
 I10HG 347
 I10HR 347
 I10R 347
 I12A 347
 I12C 347
 I12FA 347
 I12FC 347
 I12FG 347
 I12FR 347
 I12G 347
 I12R 347
 I12S 347
 I13A 347
 I15A 347
 IBT251B 350
 IBT251W 350
 INS66 350
 IPN1A 348
 IPN1C 348
 IPN1HFA 348
 IPN1HFC 348
 IPN1R 348

IPN2A 348
 IPN2C 348
 IPN2FA 348
 IPN2FC 348
 IPN2FR 348
 IPN2R 348
 IPS50A 349
 IPS50C 349
 IPS50E 349
 IPS50K 349
 IPS50P 349
 IPS75A 349
 IPS75C 349
 IPS75D 349
 IPS75L 349
 IPS75P 349
 IPV1A 348
 IPV1HC 348
 IPV1HF 348
 IPV1HR 348
 IPV2A 348
 IPV2C 348
 IPV2F 348
 IPV2R 348
 ISE13A 347
 ISE14A 347
 ISE18U 347
 ISE22U 347
 ISE23U 347
 ISE10 350
 ISE20 350
 ISE30 350
 ISE40 350
 ISEU50 350
 ISEU60 350
 ISEU70 350
 ISEU80 350

J

J200 208
 J200500 208
 J200600 208
 J200ABC25 208
 J200APS 208
 J200B 208
 J200B500 208
 J200B600 208
 J200BBC18 208
 J200BBC516 208
 J200BBC916 208
 J200SFC18 208
 J200SFC516 208
 J200SFC916 208
 J200VBC25 208
 JBU1EG 297
 JBU20EG 297
 JBU290EG 297
 JBU3EG 297

K

K0B 190
 K1B 190
 K2B 190
 K30 191
 K45 191
 K55 191
 KC1 314
 KC112 314
 KC114 314
 KC1234 314
 KC1234KC1234 315
 KC1234T 314
 KC2 314
 KC38 314
 KC38KC1 315
 KC38KC1234 315
 KO100 175
 KO125 175
 KO150 175
 KO200 175

NUMERICAL INDEX

Numerical Index

KO50 175
 KO75 175

L

LSBAR 338

M

MED12 198
 MED12A 198
 MED13 198
 MED13A 198
 MED14 198
 MED16 198
 MED2 198
 MED3 198
 MED30 194
 MED30SS 218
 MED40 194
 MED40SS 218
 MED45 194
 MED45SS 218
 MED5 198
 MED50 194
 MED50SS 218
 MED55 194
 MED55SS 218
 MED60 194
 MED60SS 218
 MED65 194
 MED7 198
 MED70 194
 MED70SS 218
 MED75 194
 MED80 194
 MED80SS 218
 MED85 194
 MED9 198
 MED90 194
 MED90SS 218
 MINE28 194
 MINE30 194
 MINE40 194
 MINE45 194
 MINE50 194
 MINE55 194

N

NC06 360
 NC10 360
 NC16 360
 ND1900 360
 ND218 360
 ND219 360
 ND220 360
 ND318 360
 ND319 360
 NP12 211
 NP18 211
 NP3 211
 NP6 211
 NP6M 211

O

OBBD 296
 OR 204

P

P 328
 P100 329
 P50 329
 P75 329
 PBD1H162EG 299
 PBD2H162FLEG 300
 PBD2H350FLEG 299
 PBD2H350SQBEG 299
 PBD4H162EG 299
 PBD4H162SQEG 300

PBD4H350EG 299
 PBD4H350S4 221
 PBD4H350S6 223
 PBD4H350SQEG 299
 PBD4H350SQS4 221
 PBD4H350SQS6 223
 PBS2H162FLEG 298
 PBS2H350FLEG 298
 PBS2H350FLS4 221
 PBS2H350FLS6 223
 PBS2H350SQEG 298
 PBS2H350SQFLEG 299
 PBS2H350SQS4 221
 PBS2H350SQS6 223
 PBS4H162EG 298
 PBS4H162S4 221
 PBS4H162S6 223
 PBS4H162SQEG 298
 PBS4H350EG 298
 PBS4H350S4 221
 PBS4H350S6 223
 PBS4H350SQEG 298
 PBS4H350SQS4 221
 PBS4H350SQS6 223
 PBSSG4H350SQEG 298
 PH 328
 PH14T 329
 PH38T 329
 PPHSR 329
 PKC1 330
 PKC114 330
 PKC1234 330
 PKC38 330
 PR14EG 301
 PR3740EG 301
 PR4360EG 301
 PR6380EG 301
 PR9010EG 301
 PRHD1624EG 302
 PRHD616EG 302
 PS100 197
 PS125 197
 PS150 197
 PS200 197
 PS250 197
 PS300 197
 PS400 197
 PS50 197
 PS75 197
 PSF18 325
 PSF18R 325
 PSF516 325
 PSF516R 325
 PSF916 325
 PSF916R 325

R

R1438N 325
 R14T 325
 R1814 324
 R1814T 324
 R1838 324
 R1838T 324
 R38T 325
 R51614 324
 R51614T 324
 R51638 324
 R51638T 324
 R91614 324
 R91614T 324
 R91638 324
 R91638T 324
 RA14 323
 RA1438N 323
 RA14T 323
 RA38 323
 RA38T 323
 RAC050HDG 288
 RAC075HDG 288
 RAC100HDG 288
 RAC125HDG 288

RAC150HDG 288
 RAC200HDG 288
 RAC250HDG 288
 RAC300HDG 288
 RAC350HDG 288
 RAC400HDG 288
 RC50 154
 RC50J 154
 RC75 154
 RC75J 154
 RF11614T 331
 RF11638T 331
 RF53214T 331
 RF53238T 331
 R014 323
 R01438N 323
 R014T 323
 R038 323
 R038T 323
 RSS 155
 RSSJ 155
 RT2BAEG 300
 RT4BAEG 300

S

S1900 335
 SB100 336
 SB50 336
 SB75 336
 SBC 335
 SBKC1 336
 SBKC1234 336
 SBKC38 336
 SBS 336
 SBS3.5 336
 SBS6 336
 SBX 333
 SCH48 214
 SCT2 207
 SCT3 339
 SCX1W 207
 SCX1XL 207
 SFC18 328
 SFC18100 320
 SFC1850 320
 SFC1875 320
 SFC18KC1 320
 SFC18KC112 320
 SFC18KC114 320
 SFC18KC1234 320
 SFC18KC2 320
 SFC18KC38 320
 SFC516 328
 SFC516KC1 320
 SFC516KC112 320
 SFC516KC114 320
 SFC516KC1234 320
 SFC516KC2 320
 SFC516KC38 320
 SFC916 328
 SFC916KC1 320
 SFC916KC1234 320
 SFC916KC38 320
 SJ162EG 296
 SJ181EG 296
 SNO10EG 260
 SNO25EG 260
 SNO25S6 222
 SNO31EG 260
 SNO37EG 260
 SNO50EG 260
 SNO50S6 222
 SNO62EG 260
 SNO75EG 260
 SNO87EG 260
 SNL025EG 261
 SNL037EG 261
 SNL050EG 261
 SNS010EG 260
 SNS025EG 260
 SNS031EG 260

T

SNS037EG 260
 SNS062EG 260
 SNS031EG 260
 SNST037EG 260
 SNST050EG 260
 SNST087EG 260
 SNT037S6 222
 SNT050S6 222
 SP2HEG 270
 SP3HEG 270
 SP4HEG 270
 SP4HS4 220
 SP4HS6 222
 SP5HEG 270
 SPP2HEG 270
 SPP4HEG 270
 SS 334
 SS100 334
 SS50 334
 SS75 334
 SSKC1 334
 SSKC1234 334
 SSS 155
 SSSJ 155
 SW025EG 269
 SW025S4 220
 SW025S6 222
 SW031EG 269
 SW037EG 269
 SW037S4 220
 SW037S6 222
 SW050EG 269
 SW050S4 220
 SW050S6 222
 SW062EG 269
 SW062S4 220
 SW062S6 222
 SW075EG 269
 SW075S4 220
 SW075S6 222
 SW087EG 269
 SWF037EG 262
 SWF050EG 262
 SWFF037EG 262
 SWFF050EG 262
 SWM037EG 262
 SWM050EG 262
 SWMF037EG 262
 SWMF050EG 262
 SWN025EG 269
 SWN037EG 269
 SWN050EG 269
 SWN062EG 269
 SWN075EG 269
 SWP2HEG 271
 SWP3HEG 271

TS50 341
 TS75 341
 TSKC1 341
 TSKC1234 341
 TSKC38 341

U

UFC2H4EG 306
 UFC2H5EG 306
 UFC2H6EG 306
 UFC2H7EG 306
 UFC2H8EG 306
 UFC4HEG 305
 UFS2H162EG 304
 UFS3H162EG 304
 UFS4H162EG 305
 UFS4H162S4 221
 UFS4H325EG 305
 UFS4H81EG 305
 UFTS3HEG 305
 UFTS3HHDEG 305
 UFX1H2S1050EG 304
 UFX1H2S750EG 304
 UFX1H2S850EG 304
 UFX3H243EG 303
 UFX3H325EG 303
 UFX3H487EG 303
 UFX3H81EG 303
 UFX5H162EG 303
 UFX5H162S4 221
 UFX8H162EG 303
 UFXD6H162EG 304
 UW25EG 306
 UW37EG 306
 UW50EG 306
 UW62EG 306
 UW75EG 306

V

VBC25 330
 VBC25R1438N 330
 VBC25R14T 330
 VBC25R38T 330

W

WBF1 212
 WFD4HEG 308
 WFD6HEG 309
 WFD8HEG 309
 WFD8HEG 308
 WFDG8HEG 308
 WFDG8HEG 308
 WFDG8HEG 308
 WFDG8HEG 308
 WFO10HEG 307
 WFO5HEG 307
 WFO8HEG 307
 WFO8HS4 221
 WFO8HS6 223
 WFOGD10HEG 308
 WFS2HLEG 306
 WFS2HREG 306
 WFS4HLEG 307
 WFS4HREG 307
 WFSG6HLEG 307
 WFSG6HREG 307
 WFT12HEG 309
 WFT6HEG 309
 WFT9HEG 309
 WFTG12HEG 309
 WS 295

X

XGP7HEG 269
 XP5HEG 269
 XP5HS4 220
 XP5HS6 222

